



University of Idaho  
College of Agricultural and Life Sciences

# **ESTIMATED IMPACTS OF PROPOSED IDAHO GEOHERMAL ENERGY PROJECTS**

by

**Steven Peterson, Lindy Widner, and James R. Nelson\***

**Department of Agricultural Economics and Rural Sociology**

**A.E. Extension Series No. 04-01**

**March 1, 2004**

**Funding for this study was provided by:**

**The U.S. Department of Energy through The Idaho  
State Department of Water Resources - Energy Division;**

**Economic Development Administration  
U.S. Department of Commerce;**

**and**

**The University of Idaho**

**College of Agricultural and Life Sciences  
Agricultural Economics and Rural Sociology  
University of Idaho  
Moscow, ID 83844-2334**

\*Economic Research Associate, Economic Research Analyst, and Professor, respectively

# Overview and Executive Summary

## of report on

### PROPOSED NEW PROJECTS FOR EMPLOYING GEOTHERMAL ENERGY IN IDAHO

This report analyzes the economic impacts of several proposed geothermal projects in Idaho. The Energy Division, Idaho State Department of Water Resources; the Economic Development Administration, U.S. Department of Commerce; and the University of Idaho sponsored the study. The authors of the study are Steven Peterson, Economic Research Associate; Lindy Widner, Economic Research Analyst; and James R. Nelson, Professor; all in the Department of Agricultural Economics and Rural Sociology, University of Idaho.

Geothermal energy is a nearly pollution-free, locally produced energy source that has potential for further development in Idaho. Geothermal energy is one of several alternative energy sources with potential; which include hydropower, wind energy, biomass, and solar energy. The need for locally produced alternative energy sources comes from a complex series of economic and political realities stretching across the globe. You cannot discuss any energy issue without examining its global and national interrelationships. Thus this report begins by discussing some international energy issues.

Chapter One addresses global energy issues and markets. This is followed by a discussion of the salient energy considerations at the U.S. national level. As part of this discussion the interrelationships between the environment and energy development are addressed. Chapter Two covers alternative energy development and sources in the United States, with an emphasis on geothermal development. Chapter Three discusses the development and economic impacts of four proposed geothermal projects in Idaho. The first proposal is the use of geothermal energy to heat a community recreation center and swimming pool in Cascade, Idaho (Valley County). The second project is the construction of a 10 megawatt (MW) power plant (later to be expanded to 30 MW) in Raft River, Idaho (Cassia County). The third project is the construction of an onion drying facility near Weiser, Idaho (Washington County). The final project at Lava Springs Hot Springs, Idaho (Bannock County) includes: constructing an enclosure for an existing outdoor pool, geothermal space heating the enclosure, and retrofitting a community center to utilize geothermal space heating. The projected economic impacts of each of the four proposed projects are reported.

The authors of this study created four county models that were used to measure the economic impacts of each of the proposed geothermal projects: 1) Valley County economy 2) Cassia County economy 3) Washington County economy, and 4) Bannock County economy. All were built using a modified Implan input/output model.

#### **Economic Impacts of the Cascade Community Center**

Cascade is considering developing a community recreation center and, in the same area, a business park. Initially it was assumed that the office space in the park would be heated by geothermal energy. However,

given the estimated low temperature of the available geothermal water (about 98°F), this is now in doubt. We estimated the potential economic impacts of adding ½ job in the recreation center and 10 new jobs in the business park. Even if the business park is not heated by geothermal, it is felt that the geothermal heated recreation center will make the business park considerably more attractive to potential clients. Cascade is a rural community making these types of impacts important to the community even though they are relatively small in magnitude.

If ten direct jobs are created in the business park and ½ direct job is created in the recreation center, they will result in a total of 14 new jobs to the community (including the direct jobs). In total this would bring into Valley County 995 thousand dollars in sales, 556 thousand dollars in value-added, 321 thousand dollars in earnings, and 48 thousand dollars in indirect business taxes. This includes the direct impacts along with the indirect and induced impacts (i.e. the multiplier effects). The overall jobs multiplier is approximately 1.33. Most of these impacts are likely to be felt in Cascade.

#### **Economic Impacts of Geothermal Power Production at Raft River**

A geothermal power plant is planned in Raft River Idaho. Initially the plant is proposed to be 10 MW, but it will be expanded up to 30MW. The planned 10 MW power plant would create estimated annual county impacts (Cassia County) of \$6.3 million in sales, \$4.9 million in value-added, \$1.4 million in earnings, 26 jobs, and \$0.718 million in indirect business taxes annually. A 30 MW power plant would bring local annual impacts of \$13.8 million in sales, \$10.9 million in value-added, \$3.1 million in earnings, 56 jobs, and \$1.580 million in indirect business taxes.

In addition, the construction impacts of a 10 MW power plant would create \$8.98 million in sales in Cassia County, \$3.7 million in value-added, \$2.8 million in earnings, 105 jobs, and \$0.228 million in indirect business taxes. These are short-run transitory economic impacts. Geothermally produced electricity is a basic, high-valued product that can be produced by rural economies. This facility would be the first of its kind in Idaho, and pave the way for future development of geothermal production of electricity.

#### **Economic Impacts of an Onion Drying Facility near Weiser**

Geothermal heat can be used to dehydrate fruits and vegetables. An onion drying facility is proposed near Weiser, Idaho (Washington County). The facility would create \$12.2 million in annual sales, \$7.4 million in value-added, \$3.4 million in earnings, 151 jobs, and \$814 thousand in indirect business taxes annually. The construction impacts would create \$8.98 million in short-run sales impacts, \$9.2 million in value-added, \$2.6 million in earnings, 112 jobs, and \$0.214 million in indirect business taxes. These are short-run transitory economic impact on the local economy.

#### **Economic Impacts of the Expansion of Lava Hot Springs**

Much of the economic base of the community of Lava Hot Springs, Idaho is associated with tourism. This tourism is tied to year-around spa activities based on local geothermal resources. There is potential for further development of these resources; and some planned improvements include: enclosing and geothermal space heating an existing pool; and retrofitting a local community center to utilize geothermal space heating. Conservative estimates of the local economic impacts of the planned additional geothermal development in Lava Hot Springs considered in this report are 3 total jobs, \$48,000 in earnings (wages and salaries of workers and profits of proprietors), \$145,000 in annual sales or gross revenues of business firms, \$75,000 in value added, and \$7,500 in indirect business taxes.

# TABLE OF CONTENTS

## PROPOSED NEW PROJECTS FOR EMPLOYING GEO- THERMAL ENERGY PROJECTS IN IDAHO

### CHAPTER ONE: GLOBAL TO U.S. ENERGY MARKETS..... 8

#### GLOBAL ENERGY MARKETS ..... 8

U.S. Dominates World Energy Use .....	8
High U.S. Average Per Capita Energy Consumption .....	10
How Much Energy to Raise to U.S. Living Standards .....	10
Are the Industrialized Nations Using up the World's Energy Supplies? .....	10
Composition of World's Energy Sources .....	12

#### THE UNITED STATES ENERGY MARKETS ..... 12

Self-Sufficient in Energy until the 1970s .....	12
What are our Future Energy Needs? .....	14
Energy Consumption by Sector .....	14
U.S. Energy Production Mix .....	14
Energy Independence, etc. ....	17
Growing U.S. Overall Fuel Efficiency .....	17

#### GREENHOUSE GASSES, ENERGY, AND THE ENVIRONMENT ..... 21

Greenhouse Gasses are Increasing .....	21
World Comparisons of Greenhouse Gasses .....	24

### CHAPTER TWO: FOSSIL FUELS TO RENEWABLES..... 26

#### U.S. PRODUCTION MIX OF ENERGY ..... 26

#### INTRODUCTION TO RENEWABLE ENERGY ..... 26

#### GEO-THERMAL ..... 28

Heat of Mankind for Thousands of Years .....	33
Heating Districts: From the World to Idaho .....	33
Heating Districts in other States and Nations .....	36
Individual Idaho Home Heating Systems .....	36
Greenhouses .....	36
Aquaculture .....	37
Crop Drying .....	37
Heat Pumps .....	37
How Geothermal Heat is Formed .....	37

## TABLE OF CONTENTS CONTINUED

Types of Geothermal Electricity Systems .....	39
U.S. D.O.E. Listing of Geothermal Advantages .....	44
Idaho Potential for Geothermal Expansion .....	44
<b>CHAPTER THREE: PROPOSED GEOTHERMAL PROJECTS .....</b>	<b>46</b>
Overview of Idaho's Economic Regions .....	46
Overview of Idaho's Economic Performance .....	47
The Basics of Economic Bases .....	49
CASCADE - VALLEY COUNTY GEOTHERMAL PROJECT .....	49
Structure of Valley County Economy 2001 .....	50
Economic Impacts of the Cascade Recreation Center/Bus. Park .....	51
RAFT RIVER - CASSIA COUNTY GEOTHERMAL PROJECT .....	53
Structure of Cassia County Economy 2001 .....	54
Economic Impacts of Geothermal Power at Raft River .....	54
WEISER - WASHINGTON COUNTY GEOTHERMAL PROJECT .....	58
Structure of Washington County Economy 2001 .....	59
Economic Impacts of the Onion/Garlic Facility .....	59
LAVA HOT SPRINGS GEOTHERMAL PROJECT .....	62
TECHNICAL FEASIBILITY AND COST ANALYSIS (LAVA HOT SPRINGS) .....	64
Lava Hot Springs Pool Complex Modifications .....	64
Lap Pool Enclosure: Construction Cost Analysis .....	64
Geothermal Space Heat Restoration .....	67
Space Heating Planned Pool Enclosure: Costs, Savings, etc. ....	69
Swimming Pool Complex Project Feasibility and Conclusions .....	72
Geothermal Space Heating Community Center .....	73
Retrofit Options Considerations, Costs and Savings .....	74
Impact of Community Center on Hot Springs Line .....	78
Community Center Project Conclusions and Recommendations .....	79
Adequacy of Resource .....	79
Potential Impacts on the Lava Hot Springs Economy. ....	80
General Characteristics of the Bannock County Economy .....	80
Local Economic Impacts of Lava Hot Springs .....	80
CONCLUSIONS .....	83
REFERENCES .....	85
APPENDIX .....	87-93

## LIST OF FIGURES AND TABLES

### FIGURES

Figure 1.1 Total World Primary Energy Consumption .....	9
Figure 1.2 Energy Use Per Capita ---Ranked Top 55 Nations .....	11
Figure 1.3 Commercial Energy Use .....	11
Figure 1.4 World Energy Use by Source-2001 .....	13
Figure 1.5 U.S. Energy Consumption/Production Gap 1949-2001 .....	13
Figure 1.6 2001 Total Energy Use per Sector .....	15
Figure 1.7 U.S. Energy use by Sector 1949-2001. ....	15
Figure 1.8 U.S. Energy Production Comparisons 1949 and 2001 .....	16
Figure 1.9 Total U.S. Petroleum Imports Versus U.S. Production - 1970-2001 .....	16
Figure 1.10. Top U.S. Oil Importing Countries 2001 .....	18
Figure 1.11 Origins of Imported Oil 1961-2001 .....	18
Figure 1.12 Overall U.S. Energy Efficiency - 1949-2001 .....	19
Figure 1.13. Energy Efficiency as a % of GDP .....	19
Figure 1.14 Energy Consumption per Person 1970-2001 .....	20
Figure 1.15 Composition of U.S. Greenhouse Gasses 2000 .....	20
Figure 1.16 Total U.S. Greenhouse Gasses 1980-2000 .....	22
Figure 1.17 U.S. Per Capita CO2 Emissions 1980-2000 .....	22
Figure 1.18 Real U.S. Output/Metric Ton of Greenhouse Gas Equivalents .....	23
Figure 1.19. World Carbon Dioxide Emissions .....	23
Figure 1.20 World Carbon Dioxide Emissions by Region .....	25
Figure 2.1 Major Energy Production Sources - Selected Years 1969-2001 .....	27
Figure 2.2 U.S. Renewable Energy Production 2001 .....	27
Figure 2.3 U.S. Renewable Energy Production 1949-2001 .....	29
Figure 2.4 Solar, Wind, and Geothermal Energy Production 1949-2001. ....	29
Figure 2.5 Hydropower Produced Electricity 2000 .....	30
Figure 2.6 Biomass Produced Electricity 2000 .....	30
Figure 2.7 Solar Produced Electricity 2000 .....	31
Figure 2.8 Wind Produced Electricity - 2000 .....	31
Figure 2.9 Total Renewable Energy Produced Electricity 2000 .....	32
Figure 2.10a U.S. Geothermal Electricity Production in 2000 .....	34
Figure 2.10b U.S. Geothermal Potential .....	34
Figure 2.11 Heating Districts in Idaho .....	35
Figure 2.12 Greenhouse Locations in Idaho .....	38
Figure 2.13 Aquaculture Locations in Idaho .....	38
Figure 2.14 Alligator Farms in Idaho .....	40
Figure 2.15 Heat Pump in Winter .....	40
Figure 2.16a Plate Boundaries .....	41
Figure 2.16b Geothermal Reservoir .....	41
Figure 2.17 Major Types of Geothermal Electricity Plants .....	42
Figure 2.18 Former Geothermal Electricity Production in Idaho .....	43
Figure 2.19 The Idaho Capitol Building Complex is Heated from Geothermal .....	43
Figure 2.20 Geothermal Electricity Producing Countries .....	45
Figure 3.1 Economic Regions of Idaho .....	48
Figure 3.2 Valley County Region .....	48
Figure 3.3 Valley County Economy 2001 .....	52
Figure 3.4 Total Economic Impacts of Cascade Industrial Park/Community Center .....	52

## LIST OF FIGURES AND TABLES CONTINUED

### FIGURES CONTINUED

Figure 3.5 Cassia County Region 2001 .....	56
Figure 3.6 Cassia County Economy 2001 .....	56
Figure 3.7 Raft River Economic Impacts of Geothermal Electricity Production .....	57
Figure 3.8 Washington County Region .....	60
Figure 3.9 Washington County Economy 2001 .....	60
Figure 3.10 Total Economic Impacts of Onion Drying Facility .....	61
Figure 3.11 Total Economic Impacts of the Construction of Onion Drying Facility .....	61
Figure 3.12 Lava Hot Springs Map .....	65
Figure 3.13 Lava Hot Springs Picture .....	65
Figure 3.10 Bannock County Region .....	81
Figure 3.11 Bannock County Economy 2001 .....	81
Figure 3.12 Total Economic Impacts of Lava Hot Springs Geothermal .....	82

### TABLES

Table 3.1 Estimated Investment Costs for Proposed Conventionally Heated Pool Enclosure, Lava Hot Springs .....	66
Table 3.2 Lava Hot Springs Pool Building Heating System Repair Estimate .....	68
Table 3.3 Estimated Investment Costs for Proposed Geothermal Heated Pool Enclosure, Lava Hot Springs .....	71
Table 3.4 Lava Hot Springs Community Center Estimated Heating Installation Costs: Options 1 and 2 ....	76
Table 3.5 Lava Hot Springs Community Center Estimated Heating Installation Costs: Option 3 .....	78

# **Economic Impacts of Proposed Idaho Geothermal Energy Projects**

By

Steven Peterson, Lindy Widner and James R. Nelson

## **Chapter One: Global and U.S. National Energy Markets**

### **Global Energy Markets**

Energy markets are becoming increasingly global. The price of gas to a customer in Grangeville, Idaho is directly affected by supply factors of oil in the middle-east and by demand factors in Europe and the rest of the world. National security and environmental issues increasingly revolve around energy.

Energy use is absolutely vital to economic development, but some of the byproducts of energy use (CO<sub>2</sub> emissions, ozone emissions, nuclear wastes) can damage the environment. Global warming is becoming an important political and economic issue. In developing nations, economic development may lead to a dramatic *reduction* in many forms of pollution such as deforestation and environmental degradation, but at the same time increase CO<sub>2</sub> emissions. Thus there is an economic and social balancing act in energy development for both industrialized nations and developing nations.

#### **U.S. Dominates World Energy Use**

A big economy needs a lot of energy. In terms of energy consumption, the U.S. consumes 97.05 quadrillion British Thermal Units (BTUs) of energy out of a world total of 403.92 quadrillion BTUs, or 24% of the total (Figure 1.1). In contrast, China consumes 10% of the world's energy, Russia 7%,



Figure 1.1

## Total World Primary Energy Consumption

(Quadrillion (10<sup>15</sup>) Btu) Year 2001

Rank	Nation	Q-BTUs	%
1	United States	97.05	24%
2	China	39.67	10%
3	Russia	28.20	7%
4	Japan	21.92	5%
5	Germany	14.35	4%
6	India	12.80	3%
7	Canada	12.51	3%
8	France	10.52	3%
9	United Kingdom	9.81	2%
10	Brazil	8.78	2%
11	Italy	8.11	2%
12	Korea, South	8.06	2%
13	Ukraine	6.08	2%
14	Mexico	6.00	1%
15	Spain	5.70	1%
16	Iran	5.18	1%
17	Australia	4.97	1%
18	Saudi Arabia	4.91	1%
19	Indonesia	4.63	1%
20	South Africa	4.60	1%
21	Netherlands	4.23	1%
22	Taiwan	4.07	1%
23	Other	3.93	1%
24	Poland	3.54	1%
25	Venezuela	2.95	1%
26	Thailand	2.90	1%
27	Turkey	2.89	1%
28	Korea, North	2.84	1%
29	Belgium	2.77	1%
30	Argentina	2.66	1%
	<b>World Total</b>	<b>403.92</b>	<b>100%</b>

Source: EIA

Japan 5%, and Germany 4%. These are estimates (as opposed to facts), because in much of the world some energy production comes from households, and household produced energy is not measured in the marketplace.<sup>1</sup>

The United States is also a big energy producer, accounting for approximately 18% of the world's energy production, or 71.7 quadrillion BTUs in 2001.

### **High U.S. Average per Capita Energy Consumption as Compared to World Average**

Average energy consumption in the U.S. is one of the highest in the world, 8<sup>th</sup> place at 8,148 per capita (KGs of oil equivalents). Qatar is first at 26,773 (KGs per capita), followed by Iceland (12,246 KGs), and Kuwait (10,529 KGs). An ordered ranking of energy use per capita can be seen in Figures 1.2 and 1.3. U.S. per capita energy consumption is 4.8 times the average per capita consumption in the world (8,148 versus 1,694). U.S. per capita energy consumption is 28 times that of the consumers in the least developed nations (8,148 versus 294).<sup>2</sup>

### **How Much Energy is Needed to Raise the Rest of the World to U.S. Living Standards?**

If the rest of the world were raised up to average U.S. energy consumption, energy use would increase 6.5 times (from a total of 306 quadrillion BTUs to 1,906 quadrillion BTUs). This analysis is based on *current* production and consumption patterns. Such patterns change over time. It is likely both production and consumption will become more energy efficient over time.<sup>3</sup> Modern technology will increase the quality and quantity of renewable energy resources.

### **Are the Industrialized Nations "Using Up" the World's Energy Supplies?**

Market forces powerfully influence energy demand and supply. A rise in the price of one particular energy source will set off a chain of market events that will ultimately reduce its use and expand the availability of alternative energy sources. Oil flow interruptions do have national security implications, but they are short-run problems. In the long-run, a hypothetical shortage in oil will drive up its price, leading to reduced oil consumption on the demand side and an increase in non-oil energy production on the supply side. Natural resources are simply a type of production inputs. They are transformed by the

## Figure 1.2

### Energy Use Per Capita---- Ranked Top 55 Nations (kg of oil equivalent per capita)

Rank	Nation	Kg/per capita	Rank	Nation	Kg/per capita
1	Qatar	26,773	28	Ireland	3,854
2	Iceland	12,246	29	Switzerland	3,704
3	Kuwait	10,529	30	Denmark	3,644
4	United Arab Emirates	10,175	31	Austria	3,524
5	Bahrain	9,858	32	Estonia	3,303
6	Luxembourg	8,409	33	Slovenia	3,288
7	Canada	8,156	34	Israel	3,241
8	United States	8,148	35	Slovak Republic	3,234
9	Trinidad and Tobago	6,660	36	Cyprus	3,203
10	Finland	6,409	37	Libya	3,107
11	Singapore	6,120	38	Spain	3,084
12	Brunei	5,870	39	Italy	2,974
13	Belgium	5,776	40	Ukraine	2,820
14	Australia	5,744	41	Greece	2,635
15	Norway	5,704	42	Turkmenistan	2,627
16	Sweden	5,354	43	Kazakhstan	2,594
17	Saudi Arabia	5,081	44	South Africa	2,514
18	New Zealand	4,864	45	Portugal	2,459
19	Netherlands	4,762	46	Venezuela, RB	2,452
20	France	4,366	47	Hungary	2,448
21	Russian Federation	4,218	48	Belarus	2,432
22	Japan	4,136	49	Poland	2,328
23	Germany	4,131	50	Hong Kong, China	2,319
24	Korea, Rep.	4,119	51	Bulgaria	2,299
25	Oman	4,046	52	Malaysia	2,126
26	United Kingdom	3,962	53	Malta	2,088
27	Czech Republic	3,931	54	Korea, Dem. Rep.	2,071
			55	Lithuania	2,032

Source: World Bank

## Figure 1.3

### Commercial energy use (kg of oil equivalent per capita) Year 2000

Region or Nation	Kg/per capita
United States	8,148
High income Nations	5,430
Russian Federation	4,218
Japan	4,136
Germany	4,131
United Kingdom	3,962
Europe & Central Asia	2,653
Upper middle income Nations	1,805
<b>World Average</b>	<b>1,694</b>
Middle East & North Africa	1,368
Middle income Nations	1,318
Lower middle income Nations	1,206
Low income Nations	971
Sub-Saharan Africa	669
Heavily indebted poor countries (HIPC)	398
Least developed countries: UN classification	294

Source: World Bank

intellect and creativity of mankind. Creativity is a renewable resource.<sup>4</sup> Thus creativity will likely lead to cleaner more efficient energy sources, including the expansion of renewable resources.

### **Composition of World Energy Sources of Production**

The world (including the U.S.) consumed 403 quadrillion BTUs of energy in 2001. Of that petroleum constituted 38%, Coal 24%, natural gas 23%, hydropower 7%, nuclear power 7%, and other renewable energy sources 1% (Figure 1.4). Oil, coal, and natural gas drive present energy consumption and production. The future will likely be dominated by renewable energy sources and energies derived from new technology. Changes in relative prices make it unlikely that the rest of the world will reach the U.S. level of development on conventional energy sources. It would be problematic to the world environment if CO<sub>2</sub> (carbon dioxide) emissions rose by a factor of 6.5 due to proportional increases of per capita energy use. Fortunately, industrial output world-wide is becoming more energy efficient, and the mix of energy production will likely change over time, reducing CO<sub>2</sub> emissions per dollar of GDP.

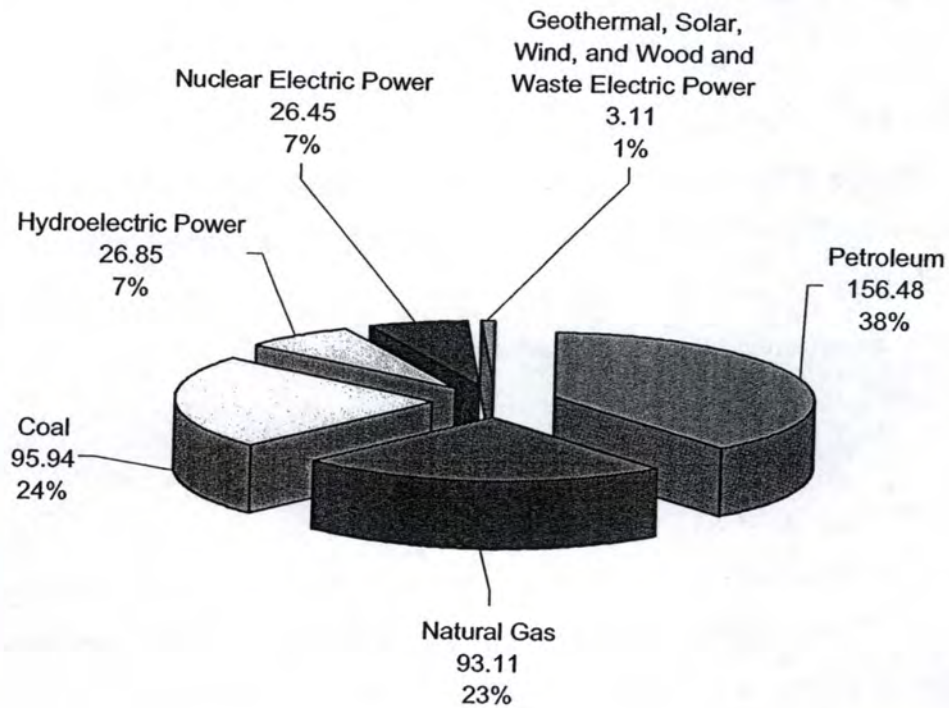
## **The United States Energy Markets**

The turbulent decade of the 1970s exposed the dependence of the U.S. on foreign energy supplies, primarily petroleum. The U.S. experienced two oil shocks during the decade, substantially raising the prices of petroleum products. This led to policy debates on how to maintain U.S. energy independence, and to the establishment of the U.S. Department of Energy as a cabinet level organization on August 4, 1977, after being signed into law by President Jimmy Carter.<sup>5</sup>

### **Self-Sufficient in Energy until the 1970s**

U.S. consumption and production of energy were nearly equal until the late 1950s. That is, the U.S. was effectively self-sufficient. From that point forward the gap between energy consumption and energy production grew steadily until a serious gap appeared in the 1970s. By 2001 the U.S.

**Figure 1.4**  
**World Energy Use by Source-2001-Quadrillions BTUs**

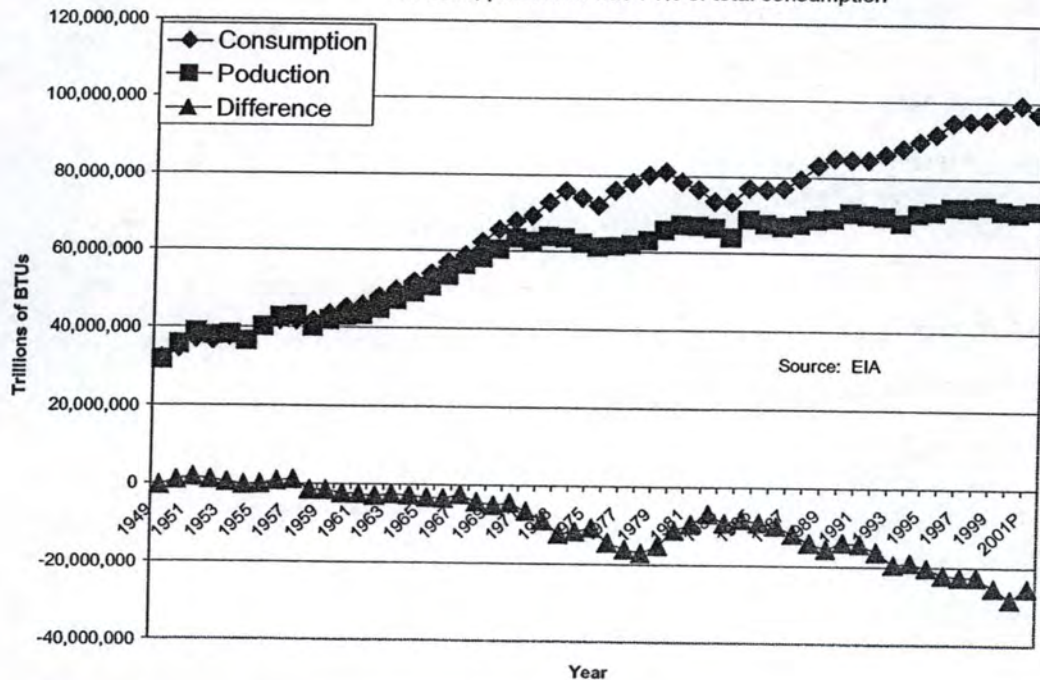


Source: EIA

**Figure 1.5**

**U.S. Energy Consumption/Production GAP 1949-2001**

In 2001, production was 74% of total consumption



Source: EIA

consumed 96.96 quadrillion BTUs and produced 71.67 quadrillion BTUs or about 74% of total consumption (Figure 1.5). Today about a quarter of the U.S. energy needs are obtained from foreign sources.

### **What are Our Future Energy Needs?**

Energy policy usually begins with forecasts, which can be problematic. There is a long history of faulty energy forecasts resulting in flawed energy policy. In 1979, the U.S. Department of Energy assembled all available long-term forecasts from various sources of energy use (over a dozen), ranging from 1972 to 2000. If we examine actual energy use in the year 2000, it is lower than all of the forecasts. What this clearly indicates is the power of the market to alter energy production and use when prices change.<sup>6</sup>

### **Energy Consumption by Sector**

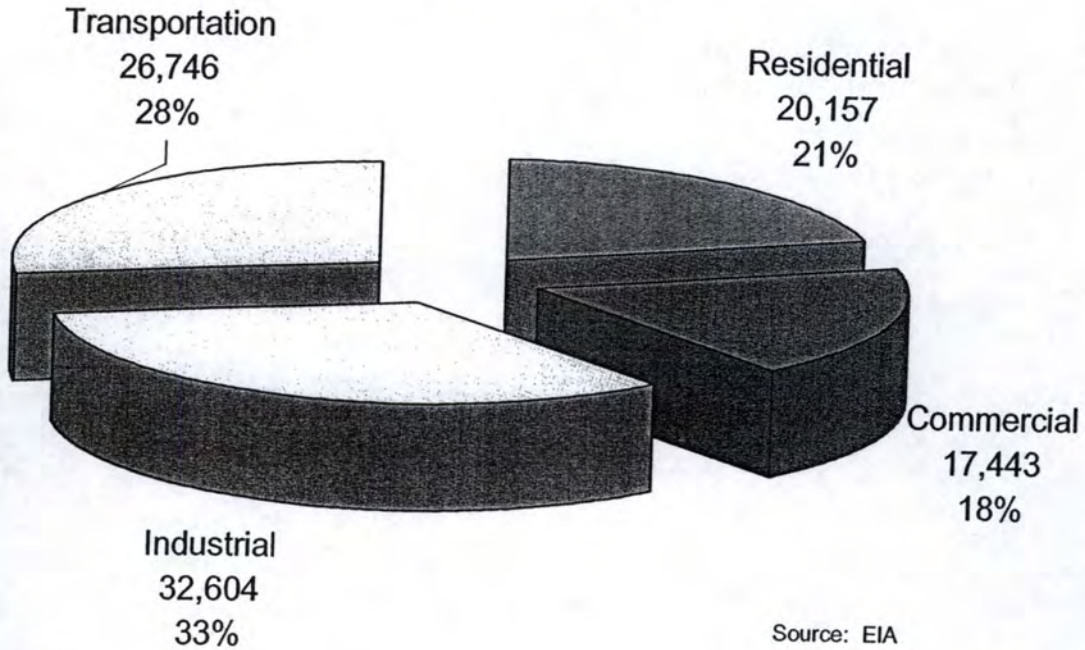
Of total U.S. energy consumption, approximately 33% comes from the industrial sector, 28% from transportation, 21% from residential, and 18% from commercial (Figure 1.6). The implications are that the biggest gains in energy conservation come from the industrial and transportation sectors.

Figure 1.7 tracks U.S. energy consumption by sector over time from 1949 to 2001. The energy price hikes in the late 1970s had the biggest impact on the industrial sector. This sector actually consumes less energy today than it did in 1979. This clearly illustrates that the U.S. manufacturing sector has actually become substantially more energy efficient over time. It also indicates the influence that the price of energy has on the consumption of energy.<sup>7</sup>

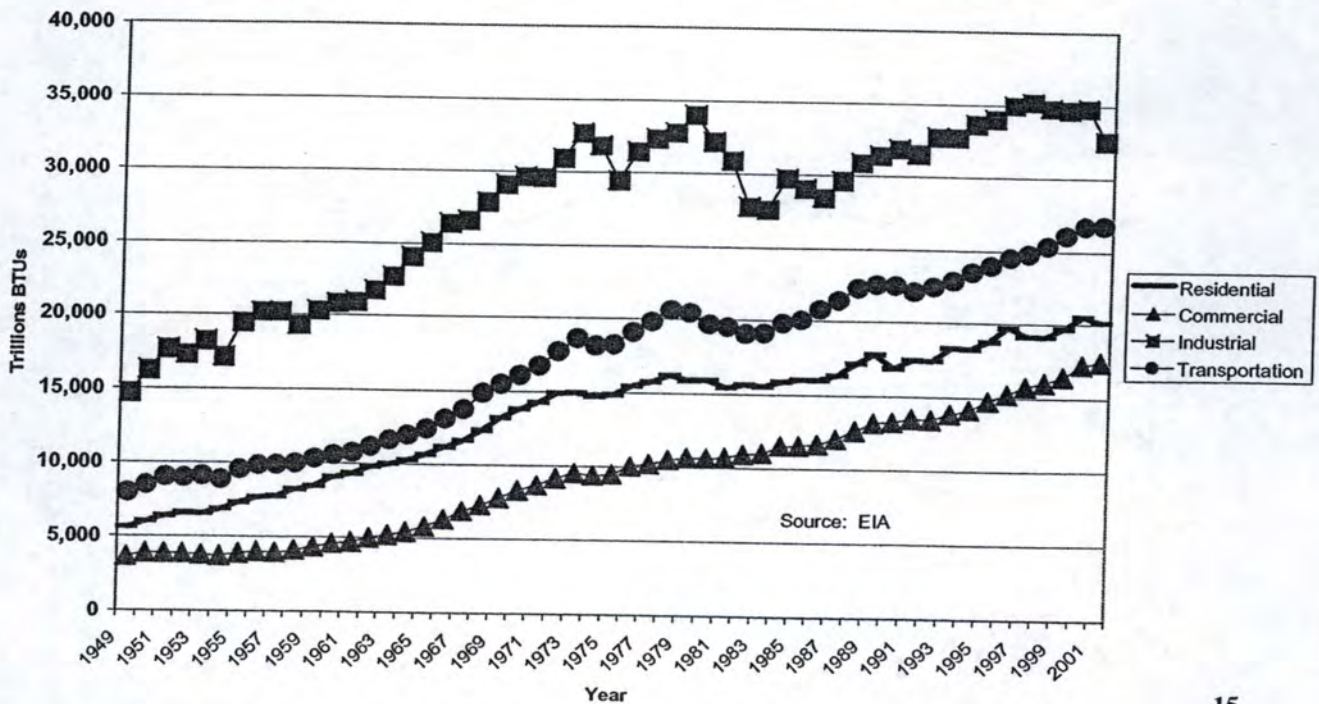
### **U.S. Energy Production Mix**

There has been a change in the relative mix of energy production in the U.S. since 1949. Coal fell from 38% to 33% of total U.S. energy production in 2001; oil production fell from 34% in 1949 to 28% in 2001; natural gas rose from 17% in 1949 to 28% in 2001. Nuclear energy production rose from 0% to 11% over the same time period. Geothermal, solar, and wind all rose from zero to 0.44%, 0.09%, and 0.08%, respectively. The production mix is moving slowly away from coal and petroleum production to other energy sources (Figure 1.8).

**Figure 1.6**  
**2001 Total Energy Use Per Sector**  
 Trillions of BTUs



**Figure 1.7**  
**U.S. Energy Use by Sector 1949-2001**



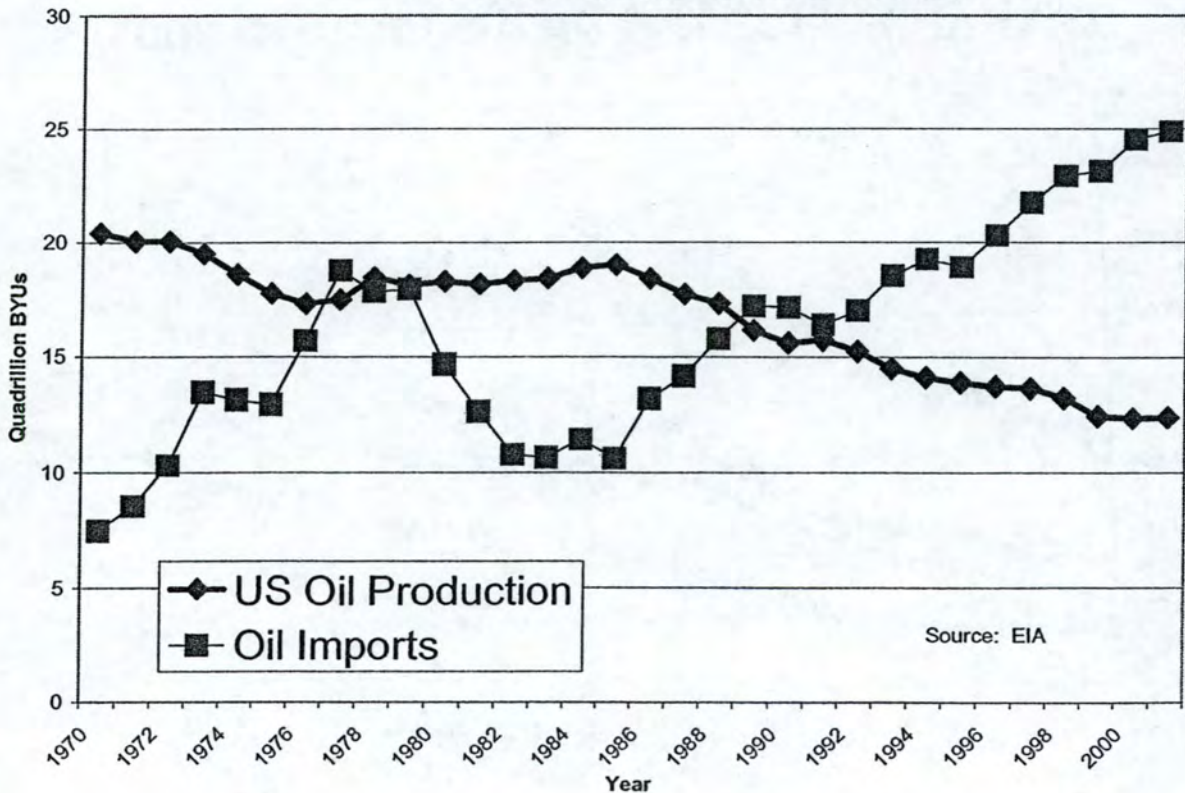
**Figure 1.8**  
**U.S. Energy Production Comparisons 1949 and 2001**

1949				2001			
Rank	Energy Type	(Quadrillion Btu)	Percentage	Rank	Energy Type	(Quadrillion Btu)	Percentage
1	Coal	11.974	37.75%	1	Coal	23.441	32.71%
2	Oil	10.683	33.68%	2	Natural Gas-Dry	19.839	27.68%
3	Natural Gas-Dry	5.377	16.95%	3	Oil	12.39	17.29%
4	Wood/Alcohol	1.549	4.88%	4	Nuclear	8.028	11.20%
5	Hydro	1.425	4.49%	5	Wood/Alcohol	2.869	4.00%
6	Natural Gas-Liquid	0.714	2.25%	6	Natural Gas-Liquid	2.541	3.55%
7	Nuclear	0	0.00%	7	Hydro	2.219	3.10%
8	Geothermal	0	0.00%	8	Geothermal	0.313	0.44%
9	Solar	0	0.00%	9	Solar	0.064	0.09%
10	Wind	0	0.00%	10	Wind	0.059	0.08%
11	Other	0	0.00%	11	Other	-0.09	-0.13%
Total		31.722	100.00%	Total		71.673	100.00%

Source: EIA

**Figure 1.9**

**Total U.S. Petroleum Imports Versus US Production--1970-2001**



Source: EIA



### **Energy Independence, Petroleum Production, and Imports**

U.S. petroleum production has been declining in absolute levels since 1970. Declining U.S. production has implications on the mix of energy production in the short-run and possibly on consumption patterns in the long-run. Imports of petroleum have exceeded U.S. domestic production since the beginning of the 1990s (Figure 1.9). U.S. oil production has fallen about 11% since 1971. Much has been written about the growing U.S. dependence on foreign oil. While it is a concern, the U.S. is energy abundant in alternatives to petroleum such as coal and natural gas. Further, future technologies will likely make renewable energy sources more cost effective.<sup>8</sup>

Of the oil imported to the U.S., approximately  $\frac{1}{2}$  comes from OPEC; which is down from 67% in 1961 (Figure 1.10 and Figure 1.11). Canada was the largest oil importer to the U.S., providing 15% of the total. This is followed by Saudi Arabia (14%), Venezuela (13%), and Mexico (12%).

### **Growing U.S. Overall Fuel Efficiency**

The U.S. economy is becoming more fuel-efficient. Energy use per dollar of output has been declining for the last 50 years (Figure 1.12). Energy expenditures per capita (adjusted for inflation) have been falling over the last 20 years (Figure 1.13). There is a perception in the public that energy has become more expensive over time. The facts do not support this perception. Energy expenditures measured as either a percentage of GDP (Gross Domestic Product -- U.S. output) or as measured in real terms (adjusted for inflation) have declined.

Energy consumption per person has varied considerably over the last 30 years, but it is less now than it was in the mid-1970s. The trend line is flat, suggesting that population growth is the primary driver in the increase of overall total energy consumption in the U.S. (Figure 1.14).

**Figure 1.10**

**Top U.S. Oil Importing Countries-2001**

Nation	Barrels/day 1,000s	%
Canada	1,786	15%
Saudi Arabia	1,657	14%
Venezuela	1,538	13%
Mexico	1,423	12%
Nigeria	854	7%
Iraq	778	7%
Norway	327	3%
United Kingdom	306	3%
Colombia	280	2%
Sub-total	8,949	77%
Total Imports	11,619	100%

Source: EIA

**Figure 1.11**

**Origins of Imported Oil 1961-2001**  
**1,000s of Barrels/Day**

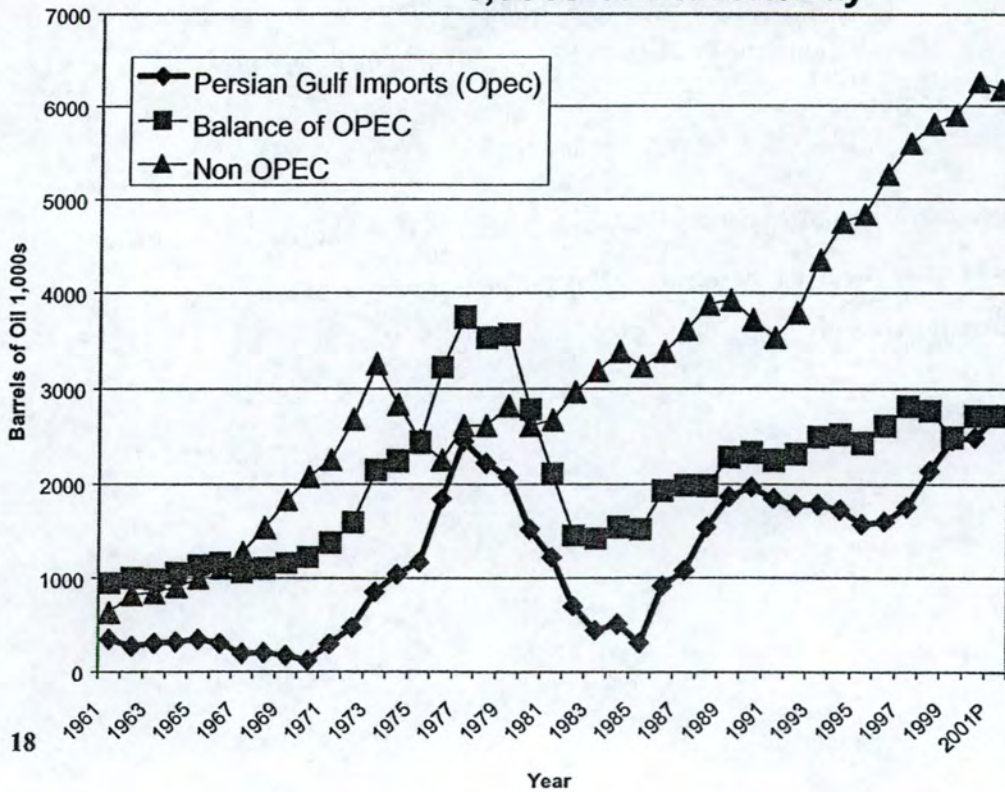


Figure 1.12

Overall U.S. Energy Efficiency 1949-2001  
1000 BTUs / \$ GDP

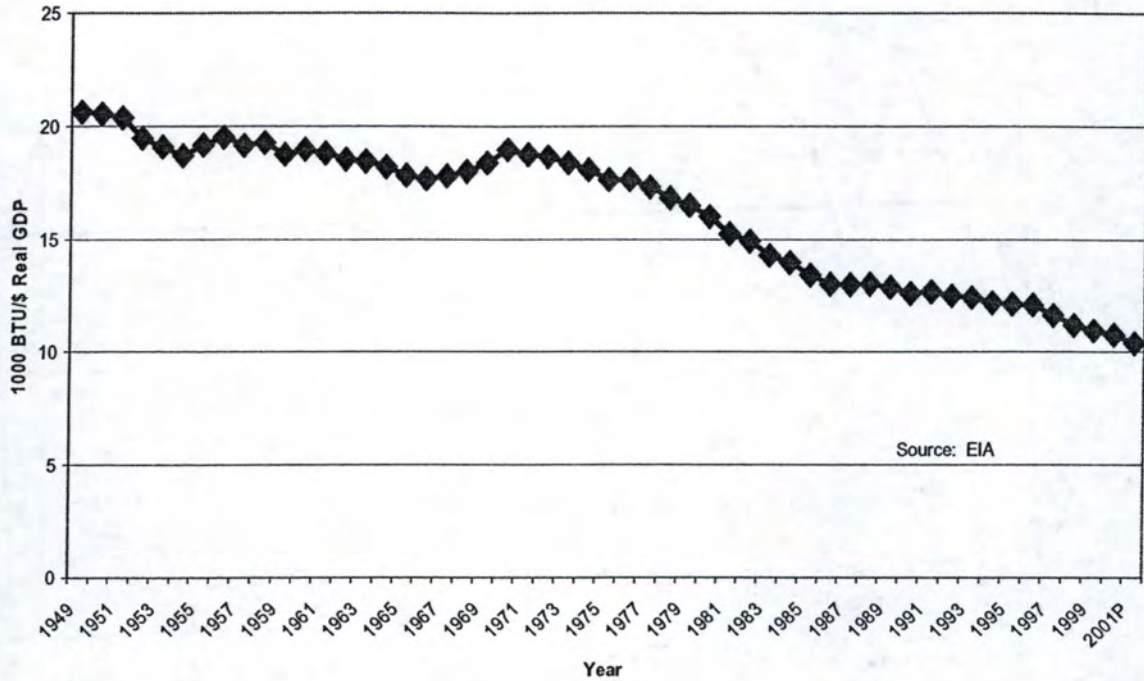
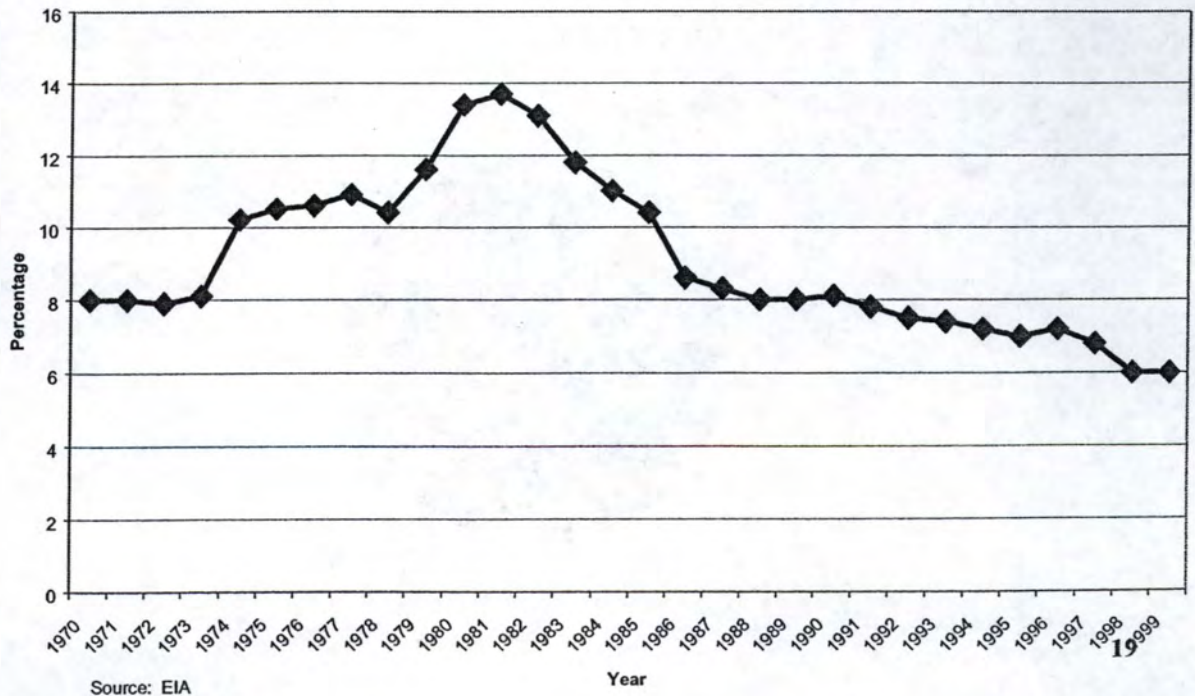
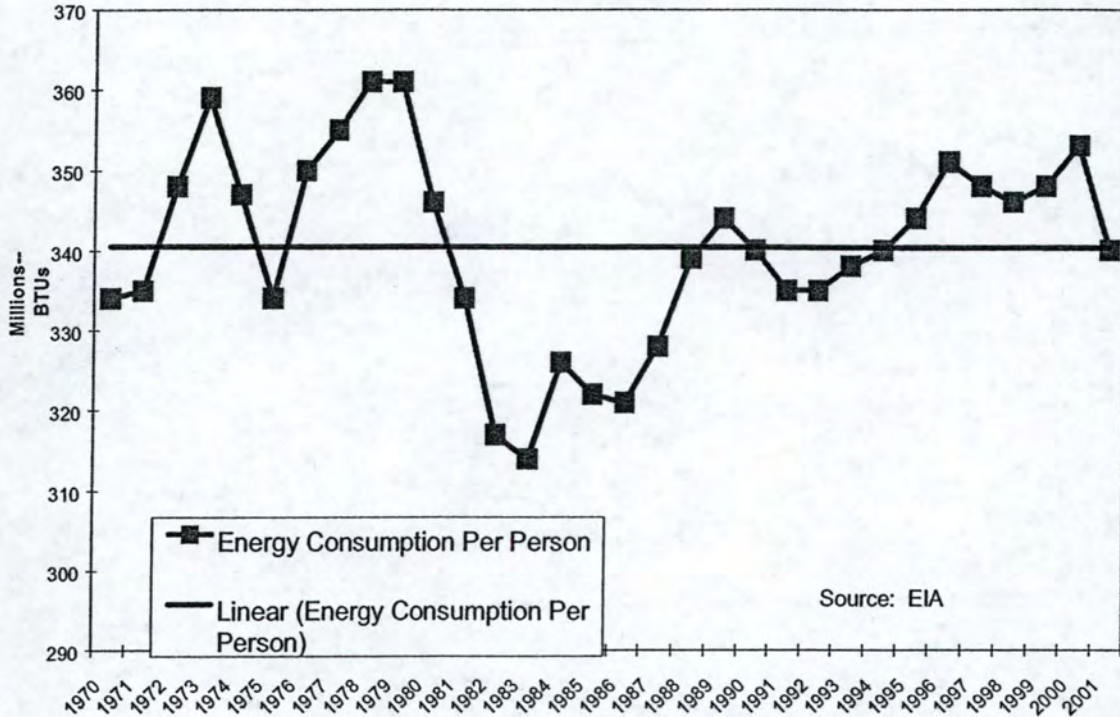


Figure 1.13

Energy Expenditures as a % of GDP

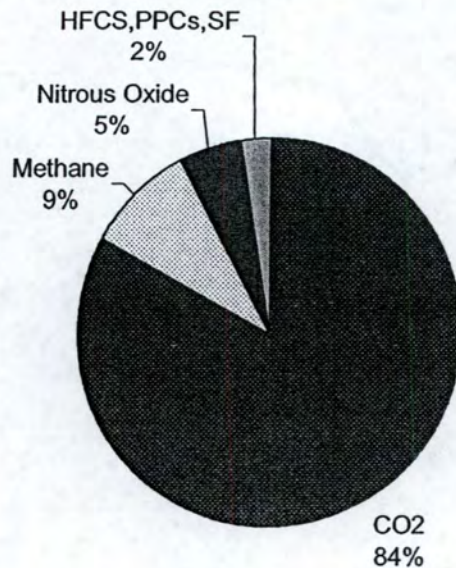


**Figure 1.14**  
**Energy Consumption Per Person**  
**1970-2001**



**Figure 1.15**

**Composition of US Greenhouse Gasses 2000**  
**Total Man-Made Greenhouse Gasses-- 1,906 Metric Tons of Carbon Equivalent**



Source: EIA

## Greenhouse Gasses, Energy, and the Environment

A discussion of energy use, sources, and policy must include discussion of the environment. Most energy production involves changing the environment. This is from the burning of fossil fuels, damming lakes or rivers, building nuclear power plants, or even building wind power "farms" that can harm birds and other wildlife. In the U.S., a protracted fight has been carried out in the Pacific Northwest over the anadromous salmon that migrate from the streams of Idaho, Washington, Oregon, and other states to the Columbia River and ultimately to the ocean. There are well over 100 dams in the region, and proposals are on the table to remove several of them to help fish migration. Even renewable energy sources such as hydropower do not have immunity from environmental issues and conflicts.<sup>9</sup>

From an international perspective global warming is a very important issue. Greenhouse gas emissions could change the climate of the planet leading to higher average temperatures and rising ocean levels. One study estimates that flooding could rise 40% in Bangladesh, a nation that already experiences serious flooding problems (over 20% of the country each year).<sup>10</sup>

International efforts have been undertaken to reduce greenhouse gases with mixed results. In 1997, 160 nations met in Kyoto, Japan, to negotiate limitations on greenhouse gases. The developed nations agreed to limit their greenhouse gas emissions, relative to the levels they emitted in 1990. The United States (under President Clinton) tentatively agreed to reduce emissions from 1990 levels by 6 percent during the period 2008 to 2012. However in 2001 the U.S. pulled backed from the Kyoto Protocol, citing possible harm to the U.S. economy. The U.S. is now pursuing bilateral agreements with individual countries rather than the multilateral agreement proposed in the Kyoto protocol."

### **Greenhouse Gasses are Increasing**

From 1989 to 1998, *anthropogenic* (greenhouse gases attributed to mankind's activities) sources of carbon in the atmosphere were estimated at 7.9 billion metric tons per year. Fossil fuels account for about

Figure 1.16

**Total U.S. Greenhouse Emissions  
1980-2000**

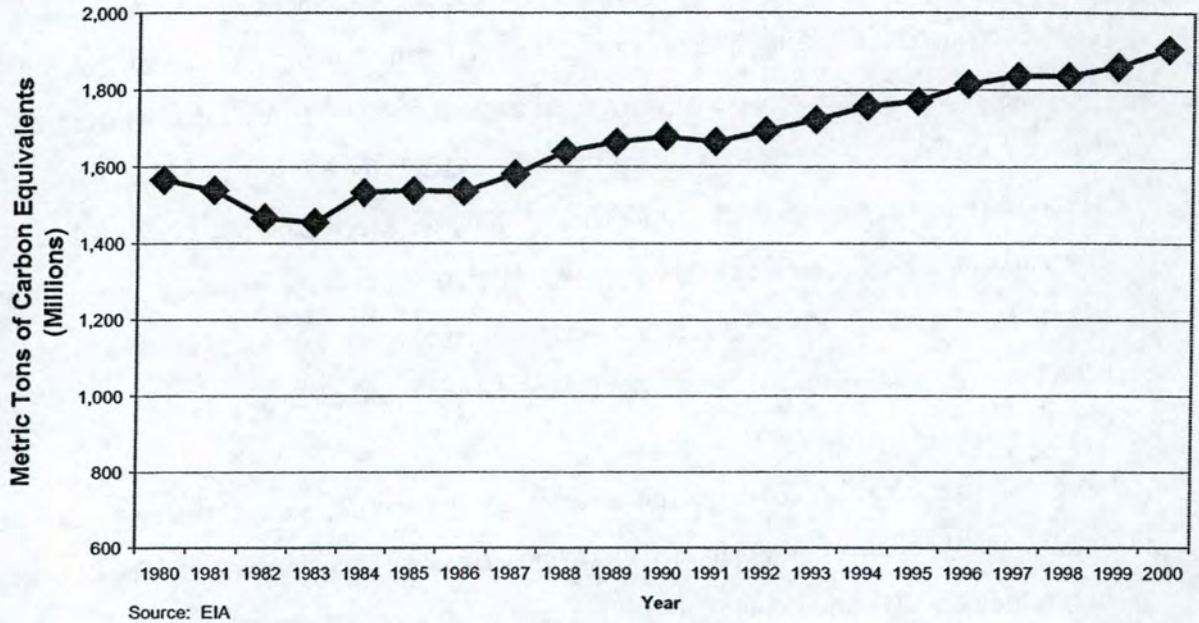
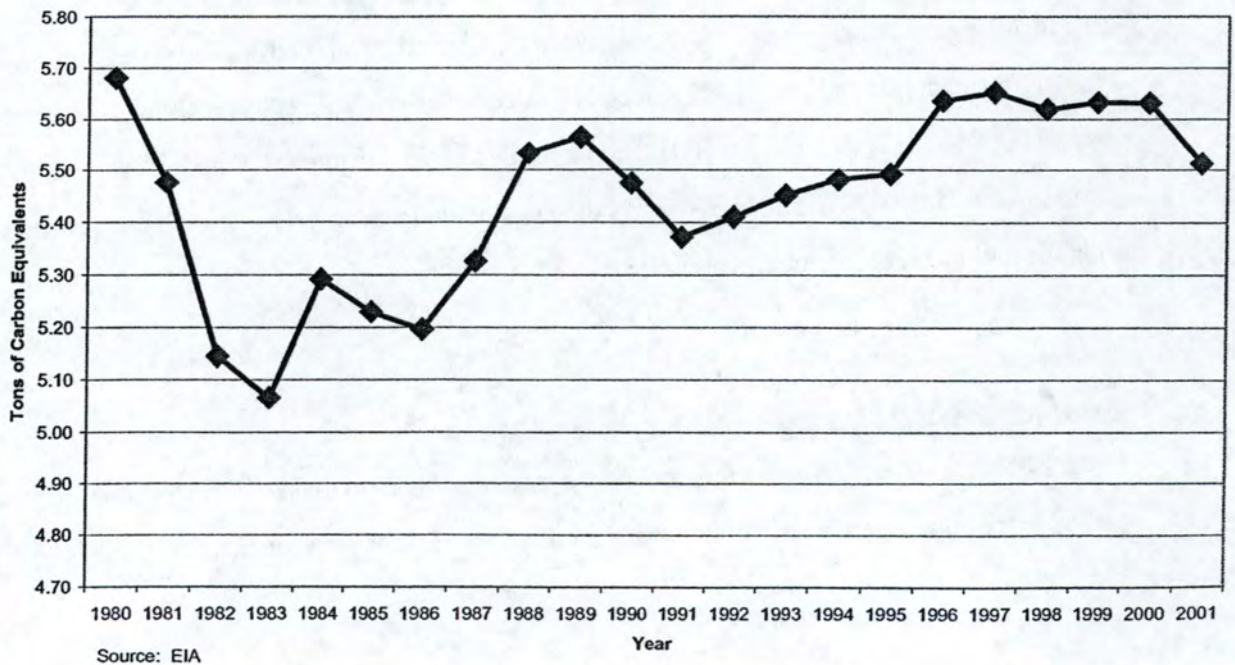
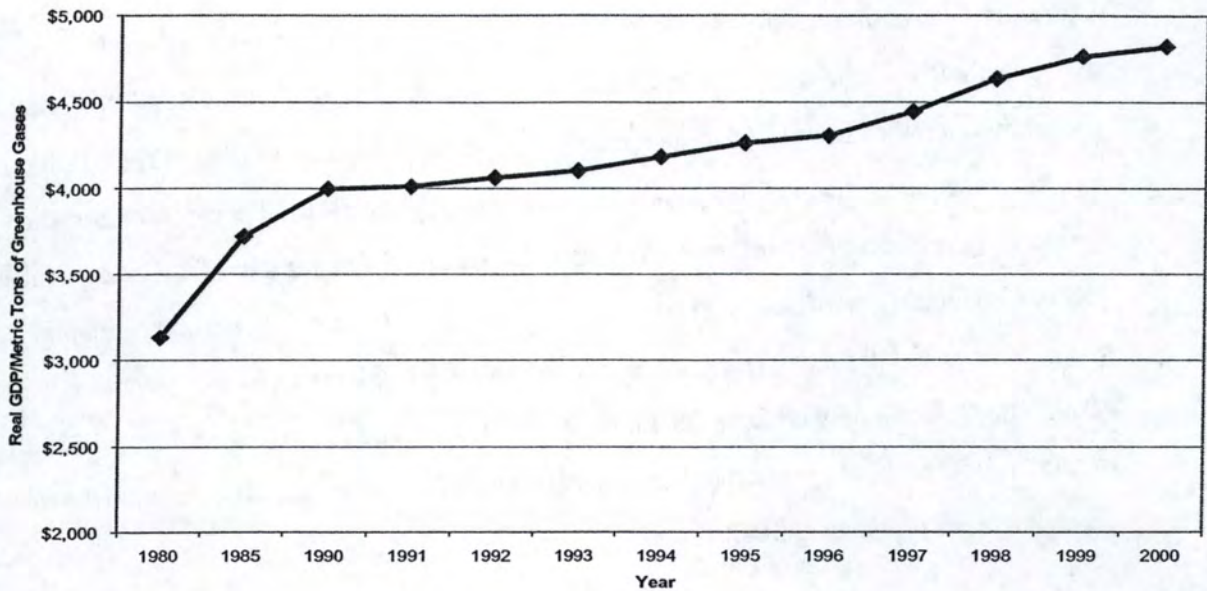


Figure 1.17

**U.S. Per Capita  
Carbon Dioxide Emissions 1980-2001**



**Figure 1.18**  
**Real U.S. Output/Metric Ton of Greenhouse Gases**  
**Equivalents**



**Figure 1.19**  
**World Carbon Dioxide Emissions**  
**from the Consumption of Petroleum, 2001**  
**(Million Metric Tons of Carbon Equivalent)**

R	Country	2001	%
1	United States	668.01	24%
2	Japan	182.06	7%
3	China	175.20	6%
4	Russia	100.53	4%
5	Africa	99.89	4%
6	Germany	94.97	3%
7	Brazil	76.38	3%
8	India	76.14	3%
9	France	72.89	3%
10	Italy	71.15	3%
11	Canada	70.40	3%
12	Mexico	68.42	2%
13	Korea, South	66.75	2%
14	United Kingdom	62.98	2%
15	Saudi Arabia	55.86	2%
	World Total	2,761.42	100%

80 percent of total emissions of carbon. Nature absorbs all the naturally produced carbon dioxide and some of mankind's contribution. The annual net increase in carbon dioxide in the atmosphere is between 3.1 and 3.3 billion metric tons.

Currently, 84% of the quantity of U.S. man-caused greenhouse gases is carbon dioxide. Methane accounts for 9%, nitrous oxide for 5%, and all other sources for 2% (Figure 1.15). Total greenhouse gases have increased from 1,565 million metric tons carbon equivalent in 1980 to 1,906 million metric tons carbon equivalent in 2000 (a 22% percent increase) (Figure 1.16). Per capita carbon dioxide emissions have been uneven but generally falling from nearly 5.7 metric tons of carbon equivalent in 1980 to 5.5 metric tons of carbon dioxide equivalent in 2001 (Figure 1.17). Total per capita greenhouse gases (all sources) have fallen from 6.9 in 1980 to 6.8 metric tons of carbon equivalent in 2000. The U.S. economy is becoming more "green" in terms of output (Figure 1.18). In 1980, one metric ton of greenhouse gas carbon equivalent produced \$3,200 of real GDP. In 2000 the same greenhouse gas produced \$4,822 of real GDP.<sup>12</sup>

### **World Comparisons of Greenhouse Gases**

The United States produces 24% of the world's carbon dioxide emissions, a magnitude consistent with our economy. Thus the U.S. has 5% of the world's population, but produces 32% of the world's output and 24% of the world's carbon dioxide emissions. Japan is second, producing 7% of the world's carbon dioxide emissions; followed by China (6%); Russia (4%); the entire continent of Africa (4%); Germany (3%); and so forth (Figure 1.19). In terms of broad regional comparisons, Asia and Oceania (Australia, etc.) produce 31% of all carbon dioxide emissions, followed by North America (28%), Western Europe (16%), Middle East (5%), Central and South America (4%), and Africa (4%). In terms of per capita emissions as a percentage of the world average, North America produces 408% of the world's per capita carbon dioxide emissions. Or put another way, the average consumer in North America produces four times the carbon dioxide emissions as the world average (Figure 1.20). This is followed by Eastern Europe and the former USSR (201%), Western Europe (199%), Middle East (171%), Central and South America (59%), Asia and Oceania (56%), and Africa (28%).



Figure 1.20

## World Carbon Dioxide Emissions (Metric Tons of Carbon Equivalent)

### Total Emissions (Millions Tons)

Country	2001	Percentage of Total Emissions
Asia and Oceania	2,068.14	31%
North America	1,817.88	28%
Western Europe	1,023.87	16%
Eastern Europe & Former U.S.S.R.	830.67	13%
Middle East	312.07	5%
Central and South America	268.27	4%
Africa	246.92	4%
<b>World Total</b>	<b>6,567.82</b>	<b>100%</b>

### Per Capita Emissions

Country	2001	Percentage of World Average
North America	4.36	408%
Eastern Europe & Former U.S.S.R.	2.15	201%
Western Europe	2.12	199%
Middle East	1.82	171%
Central and South America	0.63	59%
Asia and Oceania	0.60	56%
Africa	0.30	28%
<b>World Total</b>	<b>1.07</b>	<b>100%</b>

Source: EIA

## Chapter Two : From Fossil Fuels to Renewables

### U.S. Production Mix of Energy

Figure 2.1 illustrates changes in U.S. energy production from 1969 to 2001. Coal production has risen from approximately 14 quadrillion BTUs in 1969 to 23 quadrillion BTUs in 2001. Petroleum has fallen from approximately 20 quadrillion BTUs in 1969 to 12 BTUs in 2001. Nuclear power has risen from virtually zero in 1969 to 8 quadrillion BTUs in 2001. Future expansion of nuclear power is very unlikely in the wake of the Three-Mile Island disaster in the U.S. and especially the Chernobyl disaster in the former USSR. In fact as existing plants wear-out, nuclear energy production will likely fall in the future.

Hydropower production has remained relatively constant at about 3 quadrillion BTUs depending on the water year. Natural gas has remained relatively constant at 20 quadrillion BTUs from 1969-2001.

Renewable energy sources have many advantages for expansion in the future. Renewable energy is environmentally friendly. Renewable energy sources are “locally grown and produced”. Thus they reduce foreign dependence on energy. New technologies are creating new applications.<sup>13</sup>

### Introduction to Renewable Energy

Renewable energy sources including hydropower were responsible for approximately 5.5 quadrillion BTUs in 2001, and over time, ranges from 7% to 9% of total U.S. energy production in the U.S. depending on water availability for hydropower (Figure 2.2). The majority of this production is from wood/alcohol (biomass energy) and hydropower. In terms of hydropower, there are not many streams, rivers, or lakes on which dams can be effectively constructed. In the U.S., as well as in some other countries there are protracted conflicts over the environmental effects of existing dams. Still, overall hydropower is generally considered beneficial to the environment. Bonneville Power, for example, estimates that if the Pacific Northwest had to replace its *firm* (i.e. guaranteed) hydropower with gas-fired combustion turbines or coal-fired plants, it would add over 28.3 million metric tons of carbon dioxide to

Figure 2.1

Major Energy Production Sources --Selected Years 1969-2001

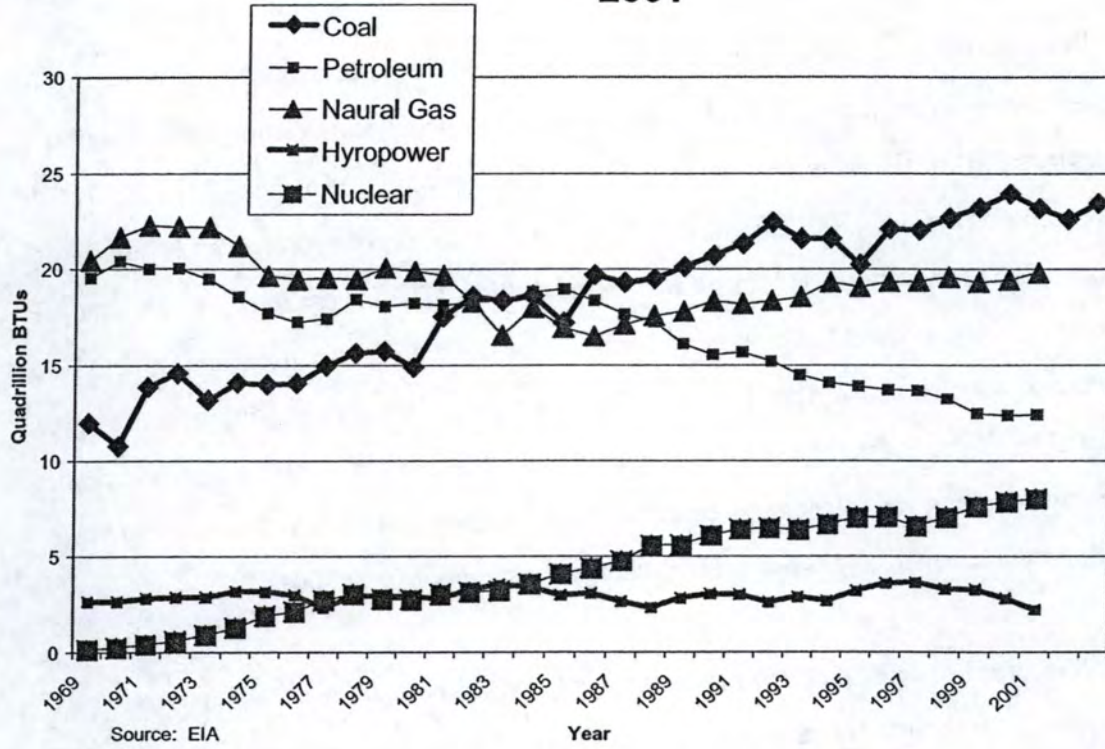
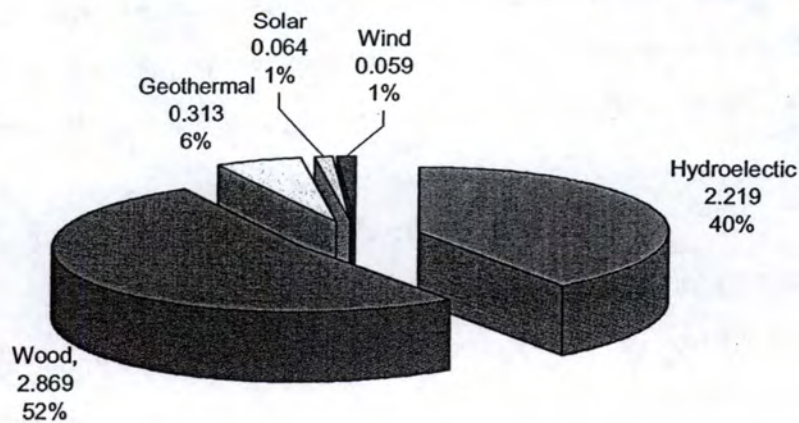


Figure 2.2

U.S. Renewable Energy Production 2001  
Quadrillion BTUs



Source: EIA

Northwest air each year, which they estimate is the equivalent of putting 5.7 million more cars on the road.<sup>14</sup>

There will clearly be opportunistic projects for the application of new technologies for some expansion of both major renewable sources. Biomass-related energy production and hydropower production constitutes over 92% of all renewable energy, 7.1% of all energy produced in the U.S., or 5.2% of all energy consumed in the U.S. (2001). Figure 2.3 illustrates the volatility of hydropower. It varied from approximately 3.85 quadrillion BTUs in 1996 to 2.2 quadrillion BTUs in year 2001—a 43% change! Hydropower is subject to water flows and weather conditions. The long-term trend line for both hydropower and wood/alcohol has been horizontal since the early 1980s showing little overall growth. The newest technologies and perhaps the more environmentally friendly renewable energy sources of geothermal, wind power, and solar energy constitute only 9% of renewable energy sources, 0.6% of total energy production, and 0.45% of total U.S. energy consumption (year 2001).

Figure 2.4 illustrates the energy production of solar, wind, and geothermal since 1949. The most substantial growth has occurred in geothermal, ranging from nearly zero in 1949 to 0.3 quadrillion BTUs in 2001. Wind energy took off in the late 1980s and had nearly surpassed solar energy by 2001, providing nearly 0.005 quadrillion BTUs of energy.

Figures 2.5 through 2.10(a) rank states by electricity produced from alternative energy sources by type for the year 2000. Idaho ranked high in hydropower production (5<sup>th</sup> overall in the nation in 2000). Idaho did not rank high in the production of energy from alternative sources, although that may change in the future due to changing technologies and future Idaho development of alternative energy sources.

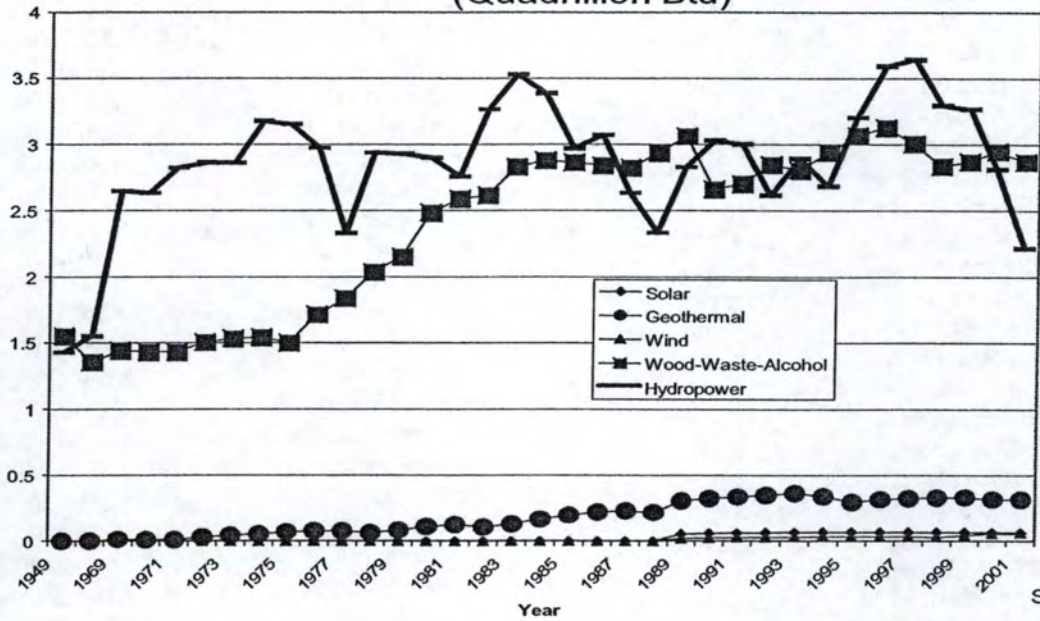
## Geothermal

While most renewable energy sources come directly or indirectly from the sun, geothermal energy comes beneath the earth's surface. This energy, once harnessed, can provide nearly pollution free electricity or heating.<sup>15</sup> Geothermal is employed either to produce electricity where the water is hot enough or used in one of five basic *direct* uses from water of lower temperatures: 1) balneology—hot

Figure 2.3

U.S. Renewable Energy Production 1949-2001

(Quadrillion Btu)



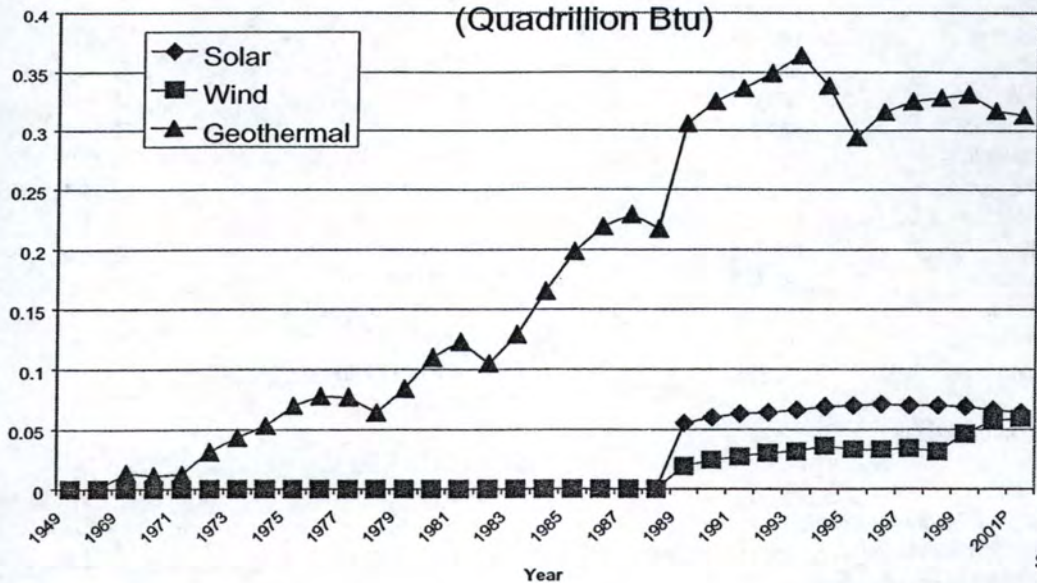
Source: EIA

Figure 2.4

Solar, Wind, and Geothermal Energy Production

1949-2001

(Quadrillion Btu)



Source: EIA

Figure 2.5

## Hydropower Produced Electricity-2000

RK	State	1,000 Kilowatts
1	Washington	80,262,889
2	California	38,333,786
3	Oregon	38,115,630
4	New York	24,909,572
5	Idaho	10,966,695
6	Montana	9,623,257
7	Arizona	8,354,216
8	Tennessee	6,396,209
9	Alabama	5,817,631
10	South Dakota	5,715,508
11	Maine	3,590,815
12	North Carolina	3,137,816
13	Georgia	2,480,797
14	Nevada	2,429,468
15	Arkansas	2,370,483
16	Kentucky	2,324,568
17	Pennsylvania	2,290,232
18	Oklahoma	2,276,933
19	North Dakota	2,122,561
20	Wisconsin	1,985,634
21	Maryland	1,732,619
22	South Carolina	1,533,490
23	Nebraska	1,500,724
24	Colorado	1,454,415
25	Michigan	1,427,679
26	New Hampshire	1,427,214
27	Vermont	1,221,090
28	West Virginia	1,150,903
29	Massachusetts	1,065,159
30	Wyoming	1,011,035
31	Alaska	1,001,819
32	Minnesota	931,383
33	Iowa	904,010
34	Texas	828,963
35	Utah	746,125
36	Virginia	711,983
37	Missouri	599,920
38	Indiana	588,276
39	Ohio	583,048
40	Louisiana	532,290
41	Connecticut	526,312
42	New Mexico	221,152
43	Illinois	143,828
44	Hawaii	103,458
45	Florida	86,769
46	Kansas	15,332
47	New Jersey	14,036
48	Rhode Island	4,867
49	Mississippi	-
50	District of Columt	-
51	Delaware	-
	Total	275,572,599

Figure 2.6

## Biomass Produced Electricity-2000

RK	State	1,000 Kilowatts
1	California	6,183,833
2	Florida	5,690,346
3	Alabama	4,076,165
4	Maine	3,821,868
5	Georgia	3,104,799
6	Michigan	2,889,594
7	New York	2,871,937
8	Louisiana	2,792,452
9	Pennsylvania	2,720,650
10	Massachusetts	2,196,818
11	Connecticut	2,153,135
12	Virginia	2,144,100
13	North Carolina	1,773,567
14	Mississippi	1,680,304
15	Arkansas	1,594,036
16	Washington	1,491,565
17	South Carolina	1,419,733
18	New Jersey	1,364,314
19	Minnesota	1,319,570
20	Texas	1,278,420
21	Wisconsin	1,150,922
22	New Hampshire	1,106,658
23	Illinois	908,391
24	Maryland	818,410
25	Tennessee	799,649
26	Ohio	647,391
27	Oregon	636,657
28	Hawaii	538,349
29	Idaho	483,258
30	Vermont	347,523
31	Oklahoma	148,187
32	Indiana	129,882
33	Rhode Island	115,239
34	Iowa	88,562
35	Missouri	82,853
36	Montana	46,923
37	Colorado	19,384
38	Delaware	18,838
39	Nebraska	16,514
40	West Virginia	14,432
41	Kentucky	12,293
42	Utah	9,110
43	New Mexico	8,464
44	North Dakota	7,975
45	Arizona	4,583
46	Alaska	0
47	District of Columbia	0
48	Kansas	0
49	Nevada	0
50	South Dakota	0
51	Wyoming	0
	Total	60,727,653

Source: Energy Information Agency, U.S. Department of Energy <http://www.eia.doe.gov/cneaf/solar.renewables/page/renewelec.html#rea2001>

Figure 2.7

**Solar Produced Electricity-2000**

RK	State	1,000 Kilowatts
1	California	493,334
2	Texas	41
<b>Total</b>		<b>493,375</b>

Figure 2.8

**Wind Produced Electricity-2000**

	State	1,000 Kilowatts
1	California	3,518,023
2	Minnesota	724,524
3	Iowa	493,820
4	Texas	492,146
5	Wyoming	245,911
6	Oregon	66,699
7	Hawaii	17,003
8	Vermont	12,249
9	New York	10,345
10	Pennsylvania	9,813
11	Wisconsin	2,728
<b>Total</b>		<b>5,593,261</b>

Source: Energy Information Agency, U.S. Department of Energy <http://www.eia.doe.gov/cneaf/solar.renewables/page/renewelec.html#rea2001>

Figure 2.9

## Total Renewable Energy Produced Electricity-2000

RK	State	1,000 Kilowatts
1	Washington	81,754,454
2	California	60,837,447
3	Oregon	38,818,986
4	New York	27,791,854
5	Idaho	11,449,953
6	Alabama	9,893,796
7	Montana	9,670,180
8	Arizona	8,358,799
9	Maine	7,412,683
10	Tennessee	7,195,858
11	Florida	5,777,115
12	South Dakota	5,715,508
13	Georgia	5,585,596
14	Pennsylvania	5,020,695
15	North Carolina	4,911,383
16	Michigan	4,317,273
17	Arkansas	3,964,519
18	Nevada	3,800,259
19	Louisiana	3,324,742
20	Massachusetts	3,261,977
21	Wisconsin	3,139,284
22	Minnesota	2,975,477
23	South Carolina	2,953,223
24	Virginia	2,856,083
25	Connecticut	2,679,447
26	Texas	2,599,570
27	Maryland	2,551,029
28	New Hampshire	2,533,872
29	Oklahoma	2,425,120
30	Kentucky	2,336,861
31	North Dakota	2,130,536
32	Mississippi	1,680,304
33	Vermont	1,580,862
34	Nebraska	1,517,238
35	Iowa	1,486,392
36	Colorado	1,473,799
37	New Jersey	1,378,350
38	Wyoming	1,256,946
39	Ohio	1,230,439
40	West Virginia	1,165,335
41	Illinois	1,052,219
42	Alaska	100,181
43	Hawaii	920,863
44	Utah	907,078
45	Indiana	718,158
46	Missouri	682,773
47	New Mexico	229,616
48	Rhode Island	120,106
49	Delaware	18,838
50	Kansas	15,332
51	District of Columbia	
	<b>Total</b>	<b>356,480,046</b>



spring and spa bathing; 2) agriculture – heating greenhouses and soil warming; 3) aquaculture, fish, prawn, and alligator farming; 4) industrial uses; 5) residential, business, and district heating. There is great potential for geothermal energy production in the U.S., mostly in the west (Figure 2.10b)<sup>16</sup>

### **Heat of Mankind for Thousands of Years**

Geothermal has been in use since the dawning of mankind. Nearly 10,000 years ago, Native Americans used geothermal spring water for cooking and medicine. The Romans treated eye and skin diseases with geothermal heat as well as heating buildings in Pompeii. The first geothermal electricity power plant was a dry steam plant, located in Tuscany, Italy nearly a century ago (in 1904). Today, France heats 200,000 homes with geothermal water.

### **Heating Districts: From the World to Idaho**

Home and business heating by a hot water or steam system is one of the most prevalent uses of geothermal energy. Water obtained from geothermal wells *heats* a hot water system through heat exchangers, either to a single household or through entire heating districts. Where multiple entities are involved, a second heat exchanger is used for each residence or business. Once used, the geothermal water is injected down a well back into the reservoir to be reheated and used again. The world's largest district heating system is in Reykjavik, Iceland. Reykjavik used to be a highly polluted city before geothermal was employed.

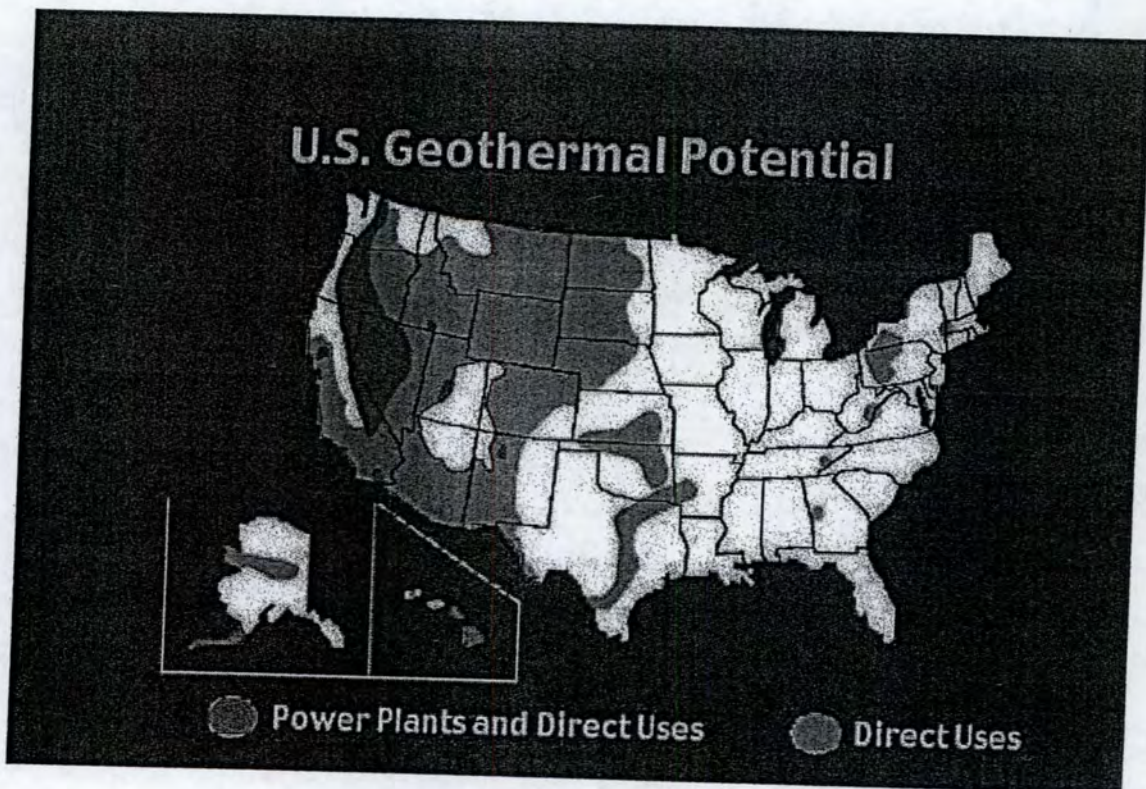
Interestingly, the first reported modern district heating system was developed in Boise, Idaho east of the Capitol in 1892. The system is still in operation, and three more district heating systems have been developed in the Boise area. These districts include the Boise Warm Springs Water District, the City of Boise, the Capitol Mall Complex, and the Veteran's Administration. These systems heat 400 homes, and businesses with 60% of the water being injected back into the reservoir for recycling. Elsewhere in Idaho, geothermal districts include the College of Southern Idaho in Twin Falls, City of Twin Falls, and Kanaka Rapids Ranch near Buhl. The Twin Falls area systems heat homes, a community college, and a high school (Figure 2.11). In the western U.S. alone there are 271 communities that have enough geothermal resources to heat homes on a wide-scale in heating districts.<sup>17</sup>

Figure 2.10a

## Geothermal Produced Electricity-2000

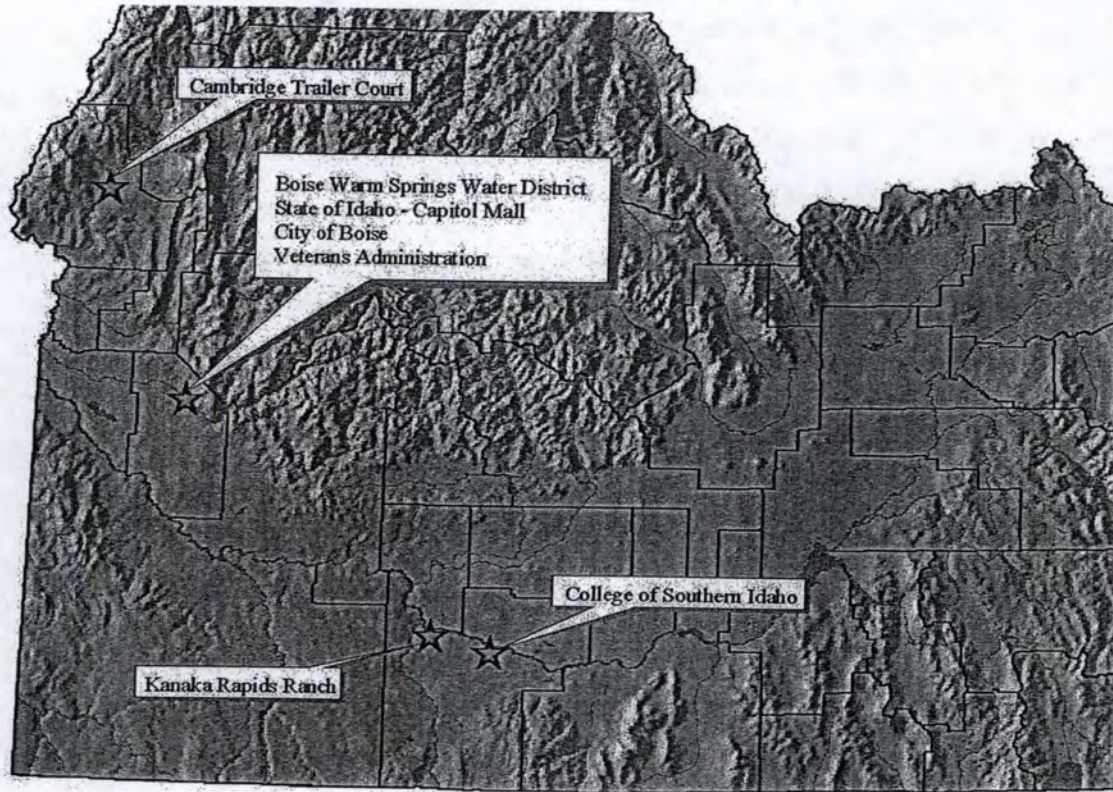
State	1,000 Kilowatts
California	12,308,471
Nevada	1,370,791
Hawaii	262,053
Utah	151,843
<b>Total</b>	<b>14,093,158</b>

Figure 2.10b



Source: <http://geothermal.marin.org/GEOpresentation/>

**Figure 2.11**  
**Heating Districts in Idaho**



[energy/alternative\\_fuels/geothermal/detailed\\_aquaculture.htm](http://energy/alternative_fuels/geothermal/detailed_aquaculture.htm)

us/

### **Heating Districts in Other States and Nations**

There are heating districts in other states including Klamath Falls, Oregon and San Bernardino, California. Soon to be developed systems include Mammoth Lakes and Bridgeport, California. Existing systems are now used around the world in countries such as Russia, China, France, Sweden, Hungary, Romania, and Japan. In New Mexico, geothermal water facilities have been installed under soil to keep the ground from freezing and to provide a longer growing season for flowers and vegetables. In Klamath Falls, Oregon, hot water from geothermal sources is piped under roads and sidewalks to keep them from freezing.

### **Individual Idaho Home Heating Systems**

In addition to heating districts, many individual homes and businesses in Idaho are heated from geothermal sources. According to the Idaho Department of Water Resources, about 50 homes are heated in the Castle Mountain Creek subdivision north of Crouch. Near Cambridge, geothermal heat is used to heat two homes and 20 trailer homes. Geothermal heat is employed in the Boise area, Givens Hot Springs area, Hagerman Valley area, and in the Twin Falls area to heat several homes and at least two churches.

### **Greenhouses**

There are geothermal greenhouses facilities located in Arizona, Idaho, New Mexico, and Utah. The first commercial greenhouse use of geothermal energy was in Boise, Idaho. The operation uses a 1000-foot well drilled in 1926. Today Idaho has 13 geothermal greenhouse facilities growing lilies, roses, poinsettias, cut flowers, potted plants, vegetables, and flower and vegetable bedding plants (Figure 2.12).

### **Aquaculture**

Geothermal aquaculture raises fish, shellfish, reptiles and amphibians throughout the world. In Japan, geothermal aqua farms grow eels and alligators.<sup>18</sup> Icelanders plan to harvest two and a half million abalone a year in the near future. In China, geothermal fish farms cover 500 acres. In Idaho, farmers grow catfish, trout, alligators, tilapia, and tropical fish (including Angel fish) for pet shops using

geothermal water. Idaho has eight separate aquaculture locations in the state, including one alligator farm (Figures 2.13 and Figure 2.14)!

### **Crop Drying**

Crop drying facilities are located throughout the world and this energy use has great opportunities for expansion.<sup>19</sup> In Nevada onions and garlic are dried using geothermal energy. In fact, Geothermal Food Processors, Inc., opened the first geothermal food-processing (crop-drying) plant in Brady Hot Springs, Nevada in 1978.

### **Heat Pumps**

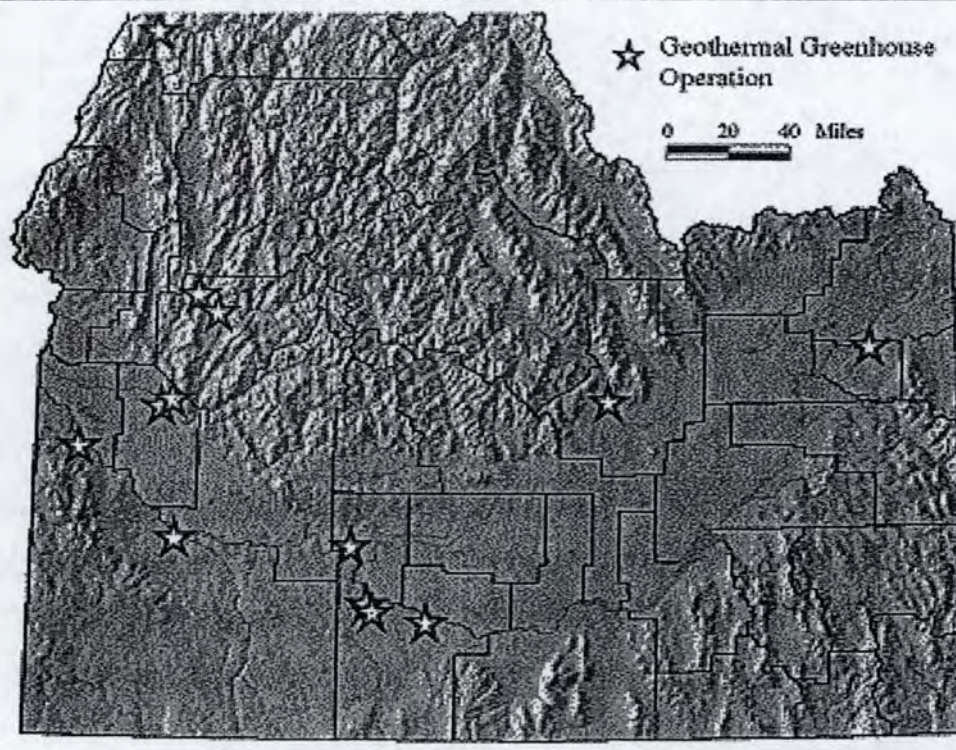
Geothermal heat pumps (GHPs) located just a few feet below the surface of the earth where the temperatures are a stable 45 - 58 degrees F, circulate water or other liquids through pipes next to a building. Depending on the weather, the system is used for heating or cooling. Nearly 300,000 homes and buildings in the U.S. utilize GHPs (Figure 2.15).

### **How Geothermal Heat is Formed**

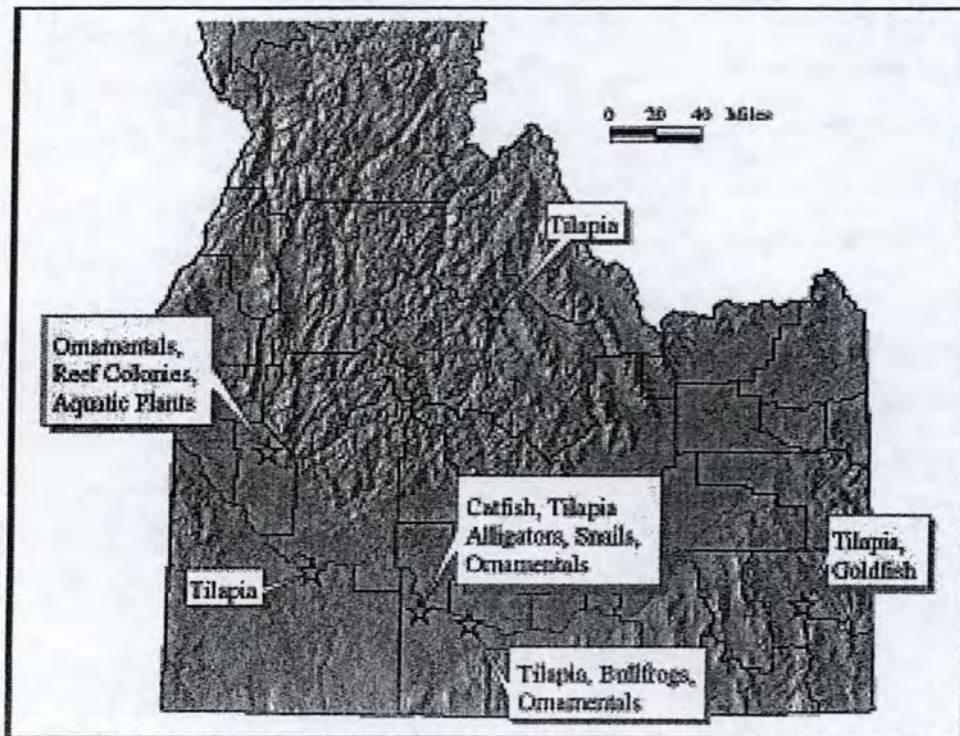
Geothermal heat originates from Earth's very formation, the gathering of space dust that occurred over 4 billion years ago, and which ultimately formed into the earth. The earth's core, which is nearly 4,000 miles deep, can produce temperatures of 9,000 degrees F. This heat flows continuously towards the surface by heating and melting the surrounding mantle rock. Heat travels from hotter interior regions of the earth to colder outer regions. This creates convective motion in the mantle rock driving plate tectonics. These plates cover the earth and drift at 1 to 5 cm per year. Where plates split apart, magma rises up into the rift, forming new crust. Where plates collide, one plate is generally forced beneath the other causing magma to melt into the crust creating vast quantities of heat (Figure 2.16a).

The crust of the earth ranges from 3 to 35 miles thick and insulates the surface from the hot interior. The magma rises slowly towards the earth's crust due to its lower density than the surrounding rock. Most

**Figure 2.12**  
**Greenhouse Locations in Idaho**



**Figure 2.13**  
**Aquaculture Locations in Idaho**



Source: Idaho Department of Water Resources, [http://www.idwr.state.id.us/energy/alternative\\_fuels/geothermal/detailed\\_aquaculture.htm](http://www.idwr.state.id.us/energy/alternative_fuels/geothermal/detailed_aquaculture.htm)

magma never reaches the surface but it gets close enough to heat rock and groundwater, sometimes to over 700° Fahrenheit. In those locations where magma reaches the surface, it can result in volcanoes. Some hot water flows through faults and reaches the earth's surface as hot springs or geysers. Most geothermal water, however, is trapped in cracks and porous rock known as geothermal reservoirs (Figure 2.16b). Hot water or steam is pushed to the surface from natural pressure or pumped to the surface from wells at temperatures 250-700°F. Shallower reservoirs of lower temperature 70-300°F are used directly to heat homes and office building. This heat has also been applied to such diverse activities as health spas, greenhouses, and fish farms. Geothermal energy has the greatest potential in the western U.S. due to the geology and plate tectonics of the region.<sup>20</sup>

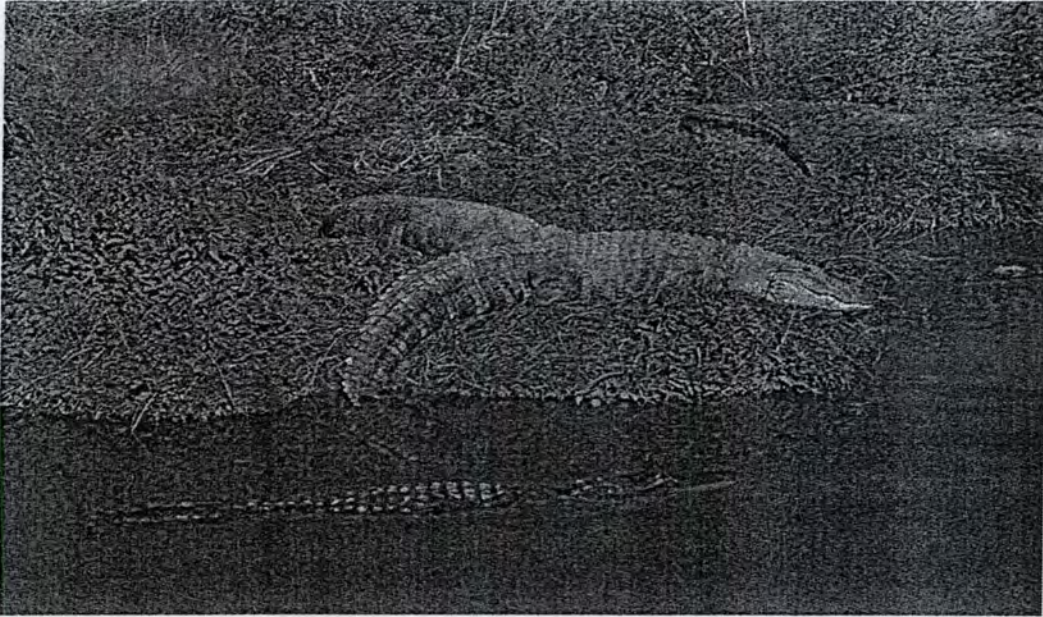
### **Types of Geothermal Electricity Systems**

There are three major types of geothermal power plants: flash steam, dry steam, and binary power plant (Figure 2.17). There are also hybrids between the three types of generating facilities. Most geothermal electricity power plants are called "flash steam" power plants, because as hot water is released from the pressure of the deep reservoir wells it flashes (boils) to steam. The steam spins turbine generators to produce electricity. The used steam is condensed into water and injected back into the earth to be recycled. Flash technology was invented in New Zealand.

Another type of geothermal power is from plants called dry steam plants. These are used in areas where steam comes directly from reservoirs. The steam is directed through a rock-catcher and into an electricity producing turbine. The *Geysers* dry steam reservoir in northern California is the largest dry field in the world and produces enough electricity to supply a city the size of San Francisco.

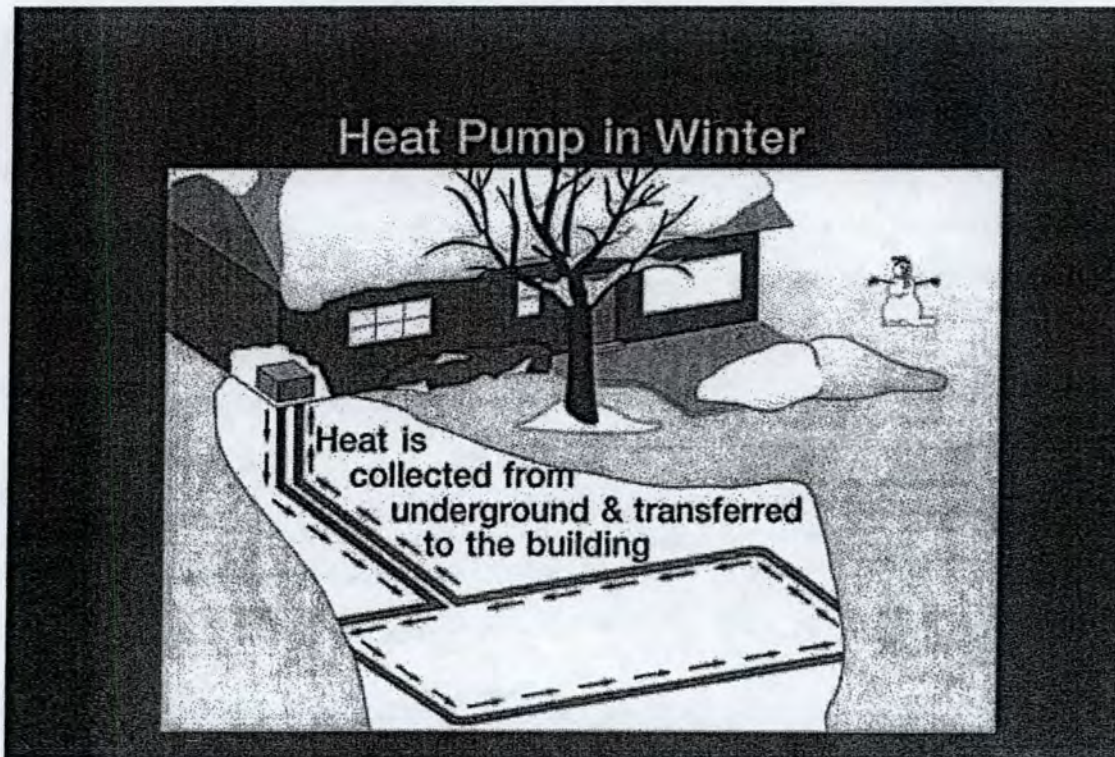
Due to changes in technology, there is great opportunity for expansion of geothermal heat using a binary power plant. In this system the geothermal water is passed through a heat exchanger making it a closed, high efficiency, geothermal power source. The fluid in the adjacent loop is isobutane or isopentane, which comes to a boil at a lower temperature than water. Thus the system can work with lower temperatures with less heat loss.<sup>21</sup> Idaho currently has no geothermal electrical facilities in the state, although one

**Figure 2.14**  
Alligator Farms in Idaho



Source: Idaho Department of Water Resources, [http://www.idwr.state.id.us/energy/alternative\\_fuels/geothermal/detailed\\_aquaculture.htm](http://www.idwr.state.id.us/energy/alternative_fuels/geothermal/detailed_aquaculture.htm)

**Figure 2.15**

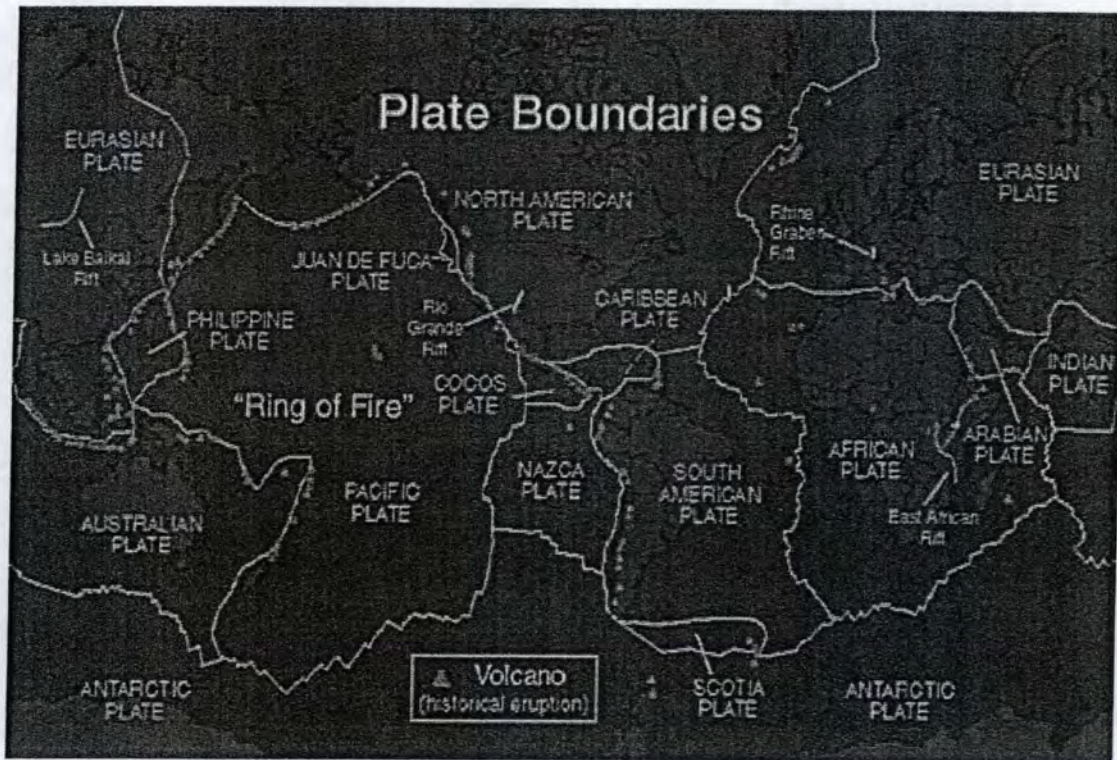


Source: <http://geothermal.marin.org/GEOpresentation/>

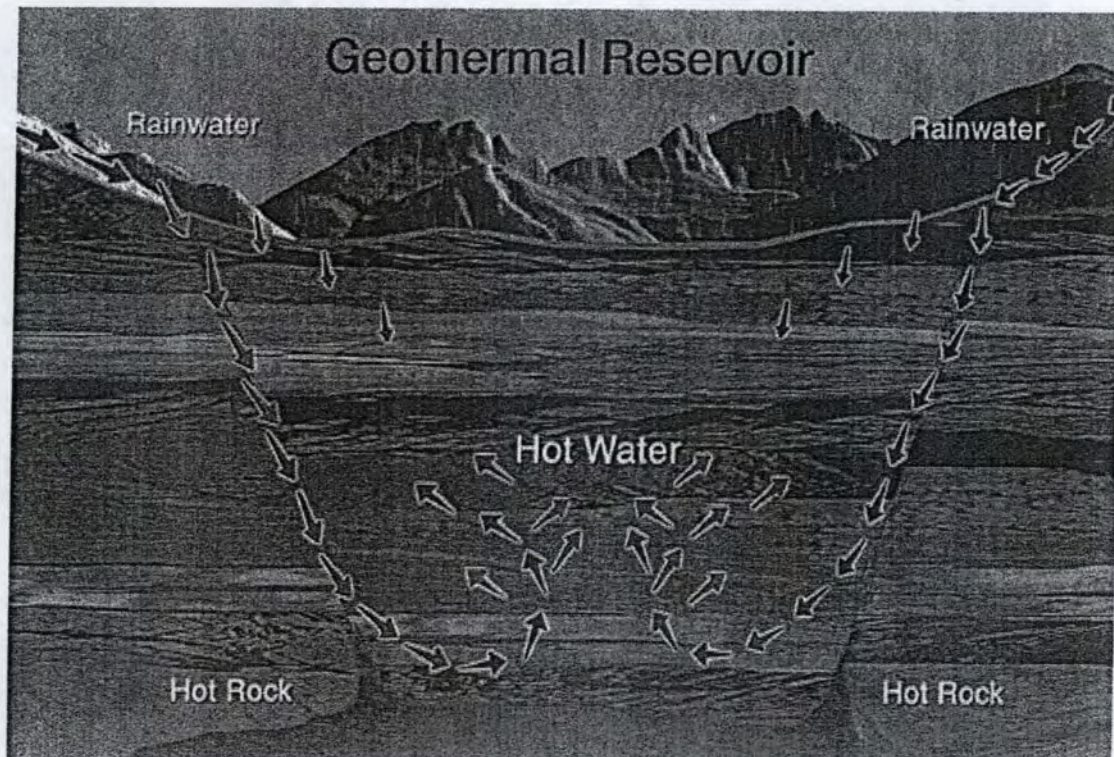


Figure 2.16

## a: Plate Boundaries

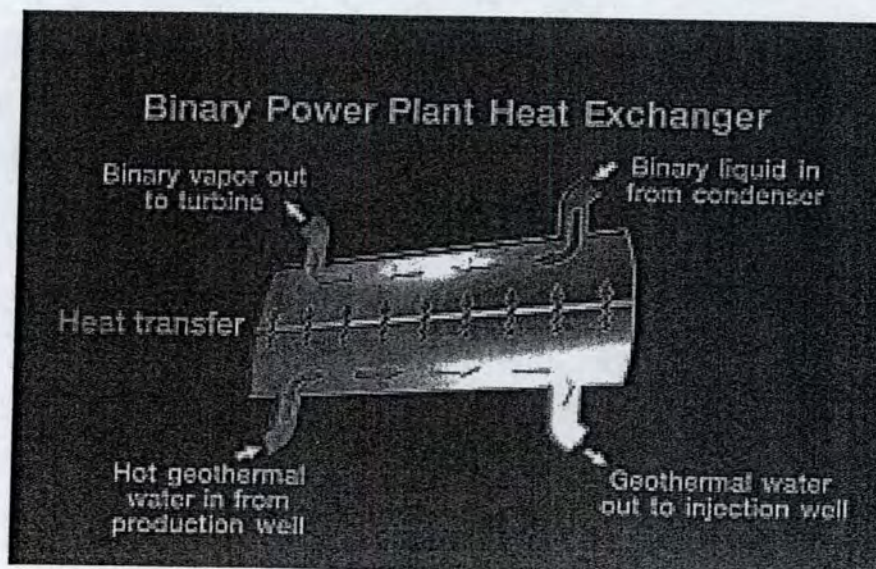
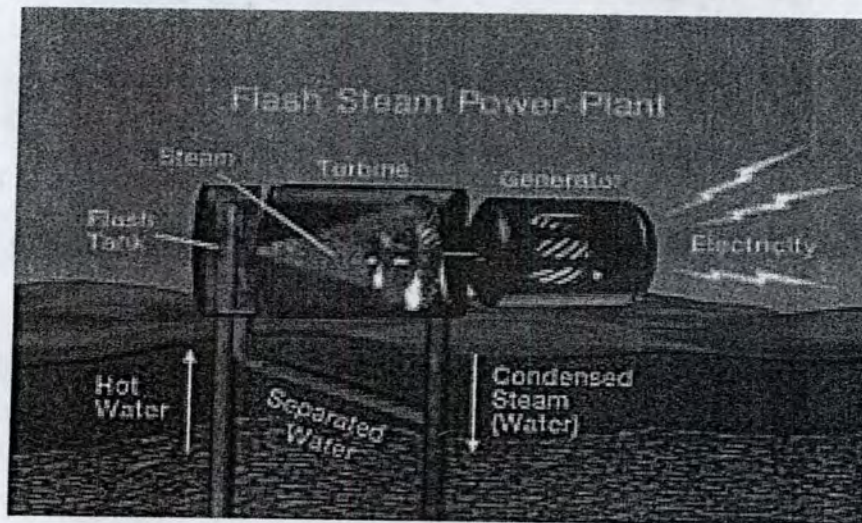
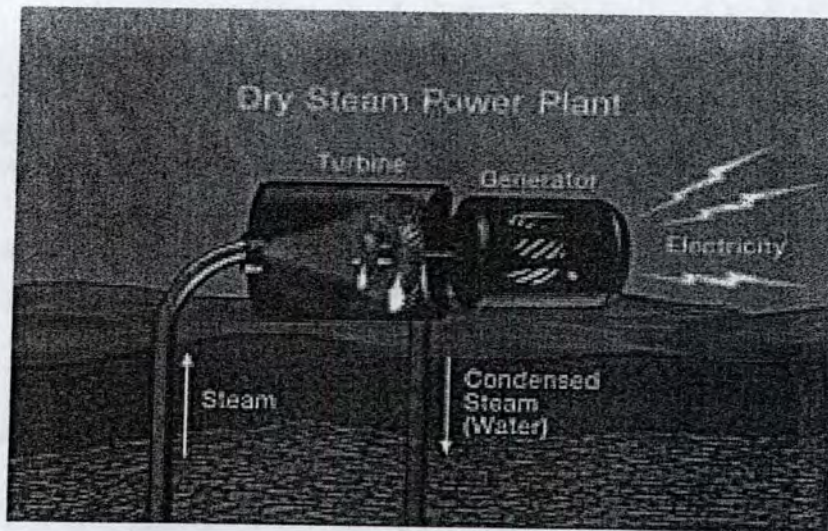


## b. Geothermal Reservoir

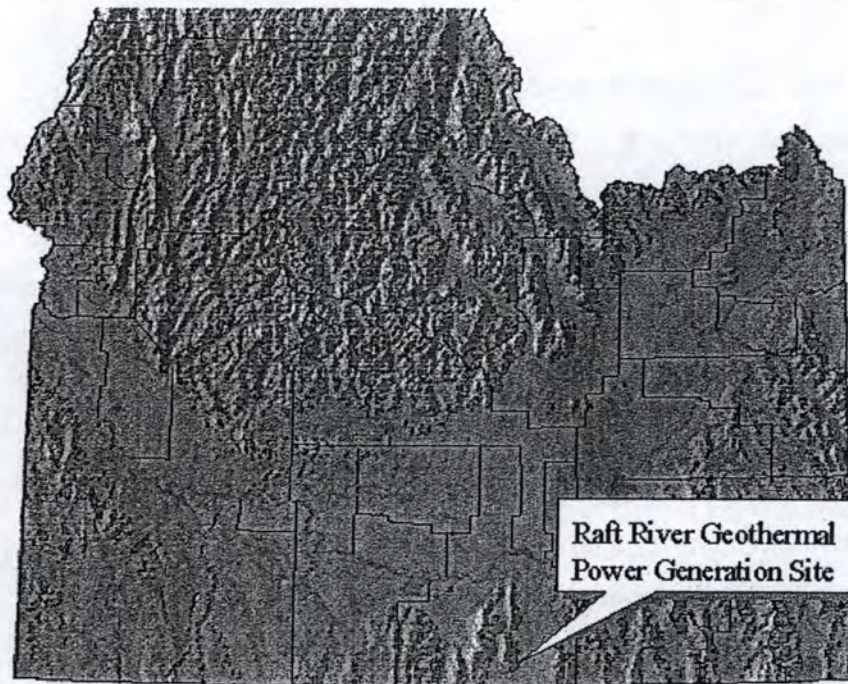


Source: <http://geothermal.marin.org/GEOpresentation/>

Figure 2.17  
Major Types of Geothermal Electricity Plants



**Figure 2.18**  
Former Geothermal Electricity Production in Idaho



Source: Idaho Department of Water Resources, [http://www.idwr.state.id.us/energy/alternative\\_fuels/geothermal/detailed\\_aquaculture.htm](http://www.idwr.state.id.us/energy/alternative_fuels/geothermal/detailed_aquaculture.htm)

**Figure 2.19**  
The Idaho Capitol Building Complex is Heated from Geothermal



Source: <http://geothermal.marin.org/GEOpresentation/sld086.htm>

operated at Raft River in Cassia County about 20 years ago. Several are under consideration for future development including another facility at Raft River (Figure 2.18 and Figure 2.19).

### **U.S. Department of Energy Listing of Geothermal Advantages**

According to the U.S. Department of Energy, geothermal energy advantages include:

- Geothermal energy provides more than 2700 megawatts (MW) of electric power to U.S. residents — comparable to 60 million barrels of oil per year, enough for 3.5 million homes. This is only a small fraction of the potential value of geothermal energy in the U.S.
- Geothermal electricity is clean — no fossil fuels are burned. Geothermal electricity produced in the U.S. displaces the emission of 22 million tons of carbon dioxide a year!
- Geothermal electricity is reliable — plants have average system availabilities of 95% or higher, compared to 60-70% for coal and nuclear plants.
- Geothermal electricity is cost-effective — today's cost of geothermal electricity ranges from \$0.05 to \$0.08 per kilowatt-hour, and technology improvements are steadily lowering that range. Also, the average geothermal power plant requires only 400 square meters of land to produce a gigawatt of power over 30 years. This compares favorably with the enormous amount of land needed for coal and nuclear plants and the open-pit and other mining required to fuel them.
- Last but not least, geothermal electricity is “homegrown” — it reduces our need to import oil, reduces the trade deficit, and adds jobs to the U.S. economy.<sup>22</sup>

### **Idaho Potential for Geothermal Expansion**

According to the Idaho Department of Water Resources, Idaho has over 2,600 wells and springs with water temperatures of 68 degrees Fahrenheit (F) or higher. There are 745 wells and 308 springs whose temperatures are greater than 85 degrees F. There are many opportunities for expansion of geothermal energy production. Geothermal waters above 85 degrees F are classified as geothermal in Idaho.

Figure 2.20

**Geothermal Electricity Producing Countries**

<i>Producing Country</i>	<i>Megawatts in 1999</i>
United States	2,850
Philippines	1,848
Italy	768.5
Mexico	743
Indonesia	589.5
Japan	530
New Zealand	345
Costa Rica	120
Iceland	140
El Salvador	105
Nicaragua	70
Kenya	45
China	32
Turkey	21
Russia	11
Portugal (Azores)	11
Guatemala	5
France (Guadeloupe)	4
Taiwan	3
Thailand	0.3
Zambia	0.2
Total	8,217

Source: Energy Information Agency



## Chapter Three:

### Proposed Idaho Geothermal Projects

In the remainder of this report, results of economic impact analyses of four proposed Idaho geothermal projects are presented. The first project is applying the use of geothermal energy to heat a swimming pool /community center in Cascade, Idaho, situated in Valley County. The second project is the geothermal production of electricity at the Raft River site, located in Cassia County. The third project is an onion/garlic geothermal drying facility near Weiser, Idaho, located in Washington County. The final project is enclosing a swimming facility and retrofitting a community center to utilize geothermal space heating at Lava Hot Springs, in Bannock County. This project includes an evaluation of the technical and economic feasibilities of the project, as well as an economic impact analysis (recorded in a separate document).

#### Overview of Idaho's Economic Regions

In order to estimate the economic impacts of each of these proposed geothermal projects, each respective county economy must be analyzed.

Political boundaries do not always coincide with economic boundaries. This is especially true in Idaho. Coeur d'Alene, Idaho for example has very little trade with the capitol, Boise, Idaho. But it does have close economic ties to Spokane, Washington. Idaho's economy is divided into three, integrated regional economic areas. The regional economic area for northern Idaho is centered in Spokane, Washington. Boise is the center of the economic area for southwestern Idaho; and Salt Lake City, Utah, for southeastern Idaho. Idaho's political boundaries bear little relationship to its economic boundaries (Figure 3.1). North Idaho, as far south as Grangeville, is dominated by the Spokane, Washington orbit. Southwestern Idaho, eastern Oregon, and northern Nevada falls in the Boise orbit (Ada and Canyon Counties). Southeastern Idaho from Twin Falls to the Wyoming border is in the

Salt Lake City orbit. Spokane, Washington; Boise, Idaho; and Salt Lake City all represent the “central places” of surrounding hinterlands. The central place is the focus of economic activity for each hub.<sup>23</sup> It is where major industries are located, where the majority of shopping and retail trade establishments exist, and where large medical centers and other vital services are located. Valley County and Washington County are located in the Boise economic region. Cassia and Bannock counties are situated in the Salt Lake City, Utah regional economy<sup>24</sup>.

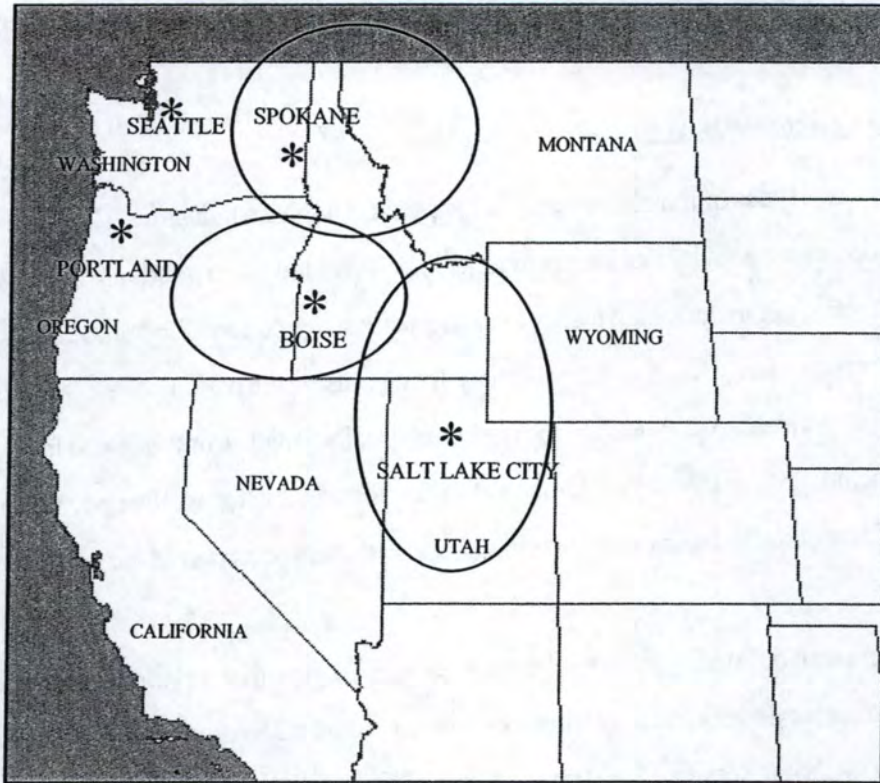
Identifying economic regions is important in economic impact analysis because a full accounting of economic impacts cannot be known without such an analysis. The economic impacts of a geothermal power plant in Raft River, for example will primarily fall on Cassia County. Some of these impacts, however, will spill-over to Twin Falls, Idaho Falls, and Pocatello. The central place of the region is Salt Lake City, Utah, and some impacts even reach there. Similarly, some of the impacts of an onion/garlic drying facility in Washington County will reach Boise, the region’s central place. Such regional impacts are less important for small projects. The economic impacts of geothermal heating of recreational facilities in Valley and Bannock counties will not be felt much in Boise and Salt Lake City.

### **Overview of Idaho’s Economic Performance**

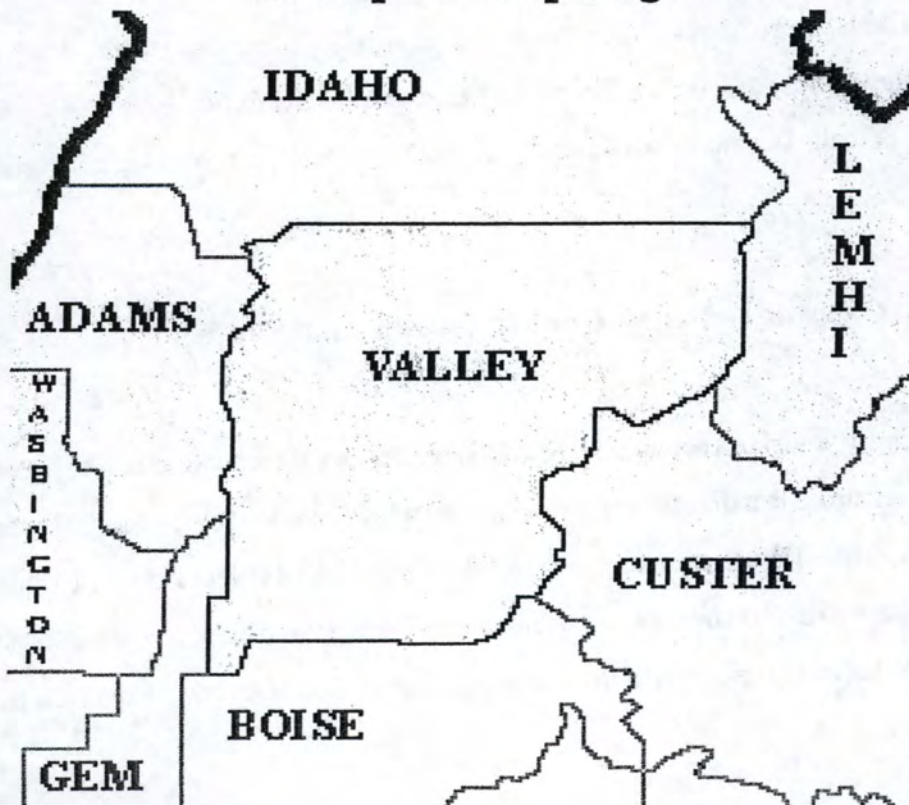
Up until the recent 2001 recession, Idaho’s overall economic performance made it one of the five fastest-growing states in the nation. In terms of total population, the state grew 29% from 1990 to 2000 as opposed to 3.1% for the nation. Only two states grew faster. Arizona (40%) and Nevada (66.3%). By April 2000, Idaho’s population had reached 1,293,953 people. This growth is in sharp contrast to the 1980s, particularly the first half of that decade, when Idaho actually had a net loss of people.<sup>25</sup> Idaho’s spectacular growth has been unevenly distributed throughout the state, concentrating mostly in the urban regions surrounding Boise and Coeur d’Alene.<sup>26</sup> There are clear dichotomies in the State of Idaho’s economic performance. One is the urban-rural split. Most of the gains in income and population have occurred in the urban regions. The second dichotomy is between the traditional natural resource industries (agriculture, mining, wood products) and newly emerging high technology and service industries. Most of the new growth is in high technology and



**Figure 3.1**  
**Idaho's Economic Regions**



**Figure 3.2**  
**Valley County Region**



related service industries.<sup>27</sup> Most geothermal development in Idaho will occur in rural regions that will help support rural economies, many of which were left out of the economic boom of the 1990s.

### **The Basics of Economic Bases**

An economy has two types of industries: base industries and nonbase industries. Base industries are defined as any economic activity that brings income into the region when goods are sold by regional firms. Base industries can include high technology companies, agriculture, food processing, and tourism. For example, firms providing services to individuals living outside the region's trade center, such as medical and legal services, are included in the region's base. Payments from state and federal governments (including social security, Medicare, funding for universities, welfare payments) are other sources of outside income to business and residents and are counted as part of the economic base.

Non-base industries are defined as economic activity within a region that supports local consumers and businesses within the base sector, recirculating incomes generated within the region. These activities include shopping malls that serve the local population, business and personal services consumed locally, and local construction contracts. Non-base industries support the base industries.

We created models of the county economies analyzed in this study using a modified Implan input/output model. A technical discussion of the model and the supporting mathematics can be found in: M. C. Guaderrama, N. Meyer, and R. G. Taylor, *Developing Coefficients and Building Input-Output Models*, University of Idaho Department of Agricultural Economics and Rural Sociology, September 2000.<sup>28</sup>

## **Cascade – Valley County Geothermal Project**

Cascade is considering developing a community recreation center and, in the same area, a business park. Initially it was assumed that the office space in the park would be heated by geothermal energy. However, given the estimated low temperature of the available geothermal water (about 98°F), this is now in doubt. We estimated the potential economic impacts of adding ½ job in the recreation center and 10 new jobs in the business park. Even if the business park is not heated by geothermal, it is felt

that the geothermal heated recreation center will make the business park considerably more attractive to potential clients.

Cascade is a medium-sized town located in Valley County. Cascade had a population of 997 in 2000, up from 833 in 1980. Valley County's population was 7,526 people in 2002, or 2.0 persons per square mile. The county ranked 30<sup>th</sup> in the state in population among counties in 2001. The State of Idaho had 15.6 persons per square mile (ppm) in 2000. In comparison Ada County had 285 ppm, and the State of New Jersey had 988 ppm. Valley County is defined as 100% rural! Valley County's population grew 25% from 1990 to 2000 but fell -1.6% from 2000-2002. In addition to Cascade, there are two other major communities in Valley County: Donnelly with 138 people and McCall with 2,084 people in 2000. McCall is a major tourist resort adjacent to a ski resort and large lake.<sup>29</sup>

Valley County lies south of Idaho County, west of Lemhi and Custer counties, north of Boise County, and east of Gem and Adams counties (Figure 3.2).<sup>30</sup> The federal government owns nearly 88% of the county and 2.9% is owned by the State of Idaho. Only 9.4% is privately owned. In terms of land use, 84.2% of the county is in forest lands. The degree of federal ownership of land creates challenges for state and local governments in Valley County. The property tax base is confined to less than 10% of the county! The county had the fourth smallest size agriculture industry in the state in terms of acreage (81,189 acres in farm land).<sup>31</sup>

In terms of income measures, per capita personal income was \$28,315 per person in 2001, which was 116% of the state average and 93.1% of the national average. This is surprisingly high given the rural nature of the county. It originates from the resort region of McCall that has a relatively high per capita income. In terms of poverty, 9.3% of the population was in poverty in Valley County in 1999 as compared to 11.8% for the State of Idaho. In terms of unemployed, the situation is reversed. In 2002, 9.2% of the county's labor force was unemployed versus 5.8% for the State of Idaho.

### **Structure of Valley County Economy in 2001**

In terms of overall structure, recreation/eating/drinking/lodging was the largest economic sector employing 1,034 workers or 17% of the county's workforce (Figure 3.3). Given the high degree of

tourism in the county, this is not surprising. This was followed by state and local government at 14% of the workforce, and trade at 13%, while services and federal government employment were tied at 8%. In rural counties state and local governments are major employers, bringing relatively high paying jobs into the county. Natural resource based industries, particularly wood products, have declined in recent years due to environmental restrictions on logging of federal forests and competition from imported Canadian lumber.

Total sales from all economic sectors in the county were approximately \$386 million, value-added was \$223 million, employee compensation was \$138 million, total employment was 5,969 people, and total indirect business taxes were \$18 million. Value added is the regional equivalent of gross domestic product (GDP), which is how economists measure the macro economy. Indirect business taxes include all taxes except corporate and personal income taxes. These numbers report total employment, sales, value added, and indirect business taxes as a size measure of economic activity without regard to causation. Causation comes from that economic activity identified as base or basic activity. In terms of the economic base of Valley County, the largest sectors are manufacturing, tourism, and state and federal government. These industries drive the Valley County economy.

#### **Economic Impacts of the Cascade Recreation Center and Business Park**

The *total* economic impacts of adding 1/2 of a new job in the planned recreation center and 10 new jobs at the business park were estimated. The results can be seen in Figure 3.4. This analysis assumes that these jobs are basic, that is, the sales bring in new money from outside the region.

If ten direct jobs are created in the business park and 1/2 direct job is created in the recreation center, they will create a total of 14 new jobs to the community (including the direct jobs). In total this would bring into Valley County, 995 thousand dollars in sales, 556 thousand dollars in value-added, 321 thousand dollars in earnings, and 48 thousand dollars in indirect business taxes. This includes the direct impacts along with the indirect and induced impacts (i.e. the multiplier effects). The overall jobs multiplier is approximately 1.33. Most of these impacts are likely to be felt in Cascade.

**Figure 3.3**  
**Valley County Economy 2001**

Industry	Sales	%	Value Added	%	Employee Compensation	%	Jobs	%	Indirect Business Taxes
Agriculture/Food Processing	16,672,207	4%	9,576,119	4%	6,342,823	5%	434	7%	714,844
Mining	674,436	0%	455,930	0%	174,146	0%	4	0%	26,878
Construction	79,785,370	21%	23,361,850	10%	20,618,726	15%	781	13%	386,201
Manufacturing	41,897,003	11%	17,761,604	8%	12,166,966	9%	264	4%	582,513
TCPU	24,659,477	6%	12,216,303	5%	6,375,943	5%	205	3%	1,676,215
Utilities	14,506,893	4%	12,232,446	5%	3,027,009	2%	16	0%	1,858,295
Trade	28,303,848	7%	22,682,249	10%	14,113,864	10%	794	13%	4,376,245
FIRE	56,070,660	15%	39,617,833	18%	6,376,693	5%	474	8%	6,018,139
Services	38,152,775	10%	19,530,512	9%	15,797,635	11%	678	11%	674,622
Recreation/Eating Drinking/Lodging	32,353,168	8%	16,586,193	7%	11,291,450	8%	1,034	17%	1,866,425
State and Local Govt	29,904,221	8%	26,152,904	12%	21,896,107	16%	810	14%	0
Federal Govt	23,402,477	6%	23,032,262	10%	19,409,571	14%	474	8%	0
	386,382,536	100%	223,206,206	100%	137,590,931	100%	5,969	100%	18,180,377

**Figure 3.4**  
**Total Economic Impacts of Cascade Industrial Park**

Industry	Sales	Value-Added	Earnings	Jobs	Indirect Business Taxes
Agriculture/Food Processing	\$ 12,717	\$ 7,304	\$ 4,838	0	\$ 545
Mining	\$ 198	\$ 134	\$ 51	0	\$ 8
Construction	\$ 32,159	\$ 9,416	\$ 8,311	0	\$ 156
Manufacturing	\$ 187,819	\$ 79,623	\$ 54,543	1	\$ 2,611
TCPU	\$ 95,108	\$ 47,117	\$ 24,591	1	\$ 6,465
Utilities	\$ 6,815	\$ 5,746	\$ 1,422	0	\$ 873
Trade	\$ 44,465	\$ 35,634	\$ 22,173	1	\$ 6,875
FIRE	\$ 199,569	\$ 141,010	\$ 22,696	2	\$ 21,420
Services	\$ 298,083	\$ 152,590	\$ 123,425	5	\$ 5,271
Recreation/Eating Drinking/Lodging	\$ 78,808	\$ 40,402	\$ 27,504	3	\$ 4,546
State and Local Govt	\$ 12,100	\$ 10,582	\$ 8,860	0	\$ -
Federal Govt	\$ 26,936	\$ 26,510	\$ 22,341	1	\$ -
<b>Total</b>	<b>\$ 994,778</b>	<b>\$ 556,067</b>	<b>\$ 320,755</b>	<b>14</b>	<b>\$ 48,770</b>

These impacts are modest but important for a community the size of Cascade. In small rural communities that are experiencing declines in traditional basic industries, every job is very valuable. Development of geothermal energy could make an important difference to such economies.

### **Raft River – Cassia County Geothermal Project**

Idaho's first commercial geothermal electrical plant is planned in Raft River (Cassia County), situated on a site where the federal government installed an experimental geothermal electricity plant over 20 years ago. It will begin as a 10 megawatt plant and ultimately be expanded to 30 megawatts, and will add Idaho to the list of states creating electricity from geothermal energy.

Cassia County's population was 21,720 people in 2002, or 8.5 persons per square mile. The county ranked 13<sup>th</sup> in the state among counties in 2001 in terms of population. The State of Idaho had 15.6 persons per square mile (pqm) in 2000. In comparison, Ada County had 285 pqm, and the State of New Jersey had 988 pqm. The county is defined as 56.1% rural and 43.9% urban. Cassia County's population grew 9.6% from 1990 to 2000, and rose 1.4% from 2000-2002.

Cassia County was established February 20, 1879. After several changes in configuration the county seat was eventually placed at Burley. The county was named for Cassia Creek. Cassia County lies to the east of Twin Falls County, south of Jerome and Minidoka counties, and east of Power and Oneida counties (Figure 3.5).<sup>32</sup> It is the top agricultural producing county in the state. Approximately 56% of the county is owned by the federal government and 3.1% is owned by the State of Idaho. Nearly 40% is privately owned, which is considerable in Idaho. The State of Idaho is 63% owned by the federal government, in contrast. In terms of land use, 67.9% of the county is in range lands. Nearly 28% is in crops, most of it irrigated. The county has the 4<sup>th</sup> largest size agriculture in the state in terms of acreage (327,869 acres in farm land). Cassia County ranked first in the state in terms of agriculture cash receipts in 1999.<sup>33</sup>

In terms of income measures, per capita personal income was \$22,121 per person in 2001, which was 90.3% of the state average and 72.71% of the national average. In terms of poverty, 13.6% of the population was in poverty in Cassia County in 1999 as compared to 11.8% for the State of Idaho. In 2002, 6.4% of the county's labor force was unemployed versus 5.8% for the State of Idaho.<sup>34</sup>

### **Structure of Cassia County Economy in 2001**

The largest economic sector in Cassia County in 2001 was agriculture and agricultural processing, employing 3,150 workers or 24% of the county's workforce (Figure 3.6). This was followed by retail and wholesale trade with 18% of the workforce, services at 17%, and state and local government at 11%. Total sales in the county were approximately \$1.161 billion, value-added was \$484 million, employee compensation was \$309 million, total employment was 12,976, and total indirect business taxes were \$38 million. In terms of the economic base of the county, clearly agriculture and food processing drive the Cassia County economy.

### **Economic Impacts of Geothermal Power Production at Raft River**

The project will begin as a 10 megawatt geothermal electricity power plant. Ultimately it is scheduled to be expanded to a 30 megawatt plant. The economic impacts are calculated in three parts. The economic impacts of the 10 megawatt plant are estimated. These represent the short-run impacts of the power plant. Secondly, the economic impacts of the 30 megawatt power plant are estimated, which represent long-run economic impacts. Third, the economic impacts of the construction of the 10 megawatt plant are estimated, effects which are transitory. They will occur during construction of the 10 megawatt plant. If the 10 megawatt plant is expanded to a 30 megawatt plant, the impacts will occur approximately twice more during the time of the expansions. These results include the direct and indirect effects (including the induced effects).

Annual economic impacts of scenarios for geothermal power production at Raft River were based on estimates of revenues and costs and expected distributions of revenues and costs. The results of the impact analysis reported in Figure 3.7 include the direct impacts as well as the indirect and induced impacts (i.e. the multiplier effects). The 10 MW powerplant would create economic impacts on Cassia

County of \$6.3 million in annual sales, \$4.9 million in value-added, \$1.4 million in earnings, 26 jobs, and \$0.718 million in indirect business taxes. Figure 3.7 illustrates these impacts and also how they would be distributed across economic sectors. For example, in the jobs category the model projects 10 jobs (out of the 26 jobs) would be in the utilities industry, 5 jobs would be in services, and 4 jobs would be in the trade sectors. The 30 MW power plant would create \$13.8 million in annual sales, \$10.9 million in value-added, \$3.1 million in earnings, 56 jobs, and \$1.580 million in indirect business taxes. It is interesting to note that the impacts of a 30MW plant would be less than three times as large as the impacts of a 10 MW plant. This is because of economies of size which mean that less total inputs (expenditures) are required per unit of output for a large plant than for a small one. Since economic impacts are largely related to expenditures, impacts per unit of output will be less for large plants than for small plants, in industries where economies of size exist.

The total construction budget was \$21.2 million. The 10 MW power plant turbines costing \$12 million were subtracted (since it is an out-of-region purchase). Of the remaining \$9.2 million, it is estimated that 60% is labor and 40% is materials purchased out of the region. Thus \$5.5 million was entered into the economic model. The construction impacts of the 10 MW powerplant would create \$8.98 million in sales in Cassia County, \$3.7 million in value-added, \$2.8 million in earnings, 105 jobs, and \$0.228 million in indirect business taxes. These are short-run transitory economic impacts. However, if the 10 megawatt plant is expanded to a 30 megawatt plant the construction impacts at that time will be approximately two times the initial construction impacts.

Geothermal produced electricity is a basic, high valued product that can be produced by some rural economies in Idaho. If constructed, the Raft River facility will be Idaho's first geothermal power plant and could have paved the way for future development of geothermal production of electricity in Idaho.



Figure 3.5  
Cassia County Region

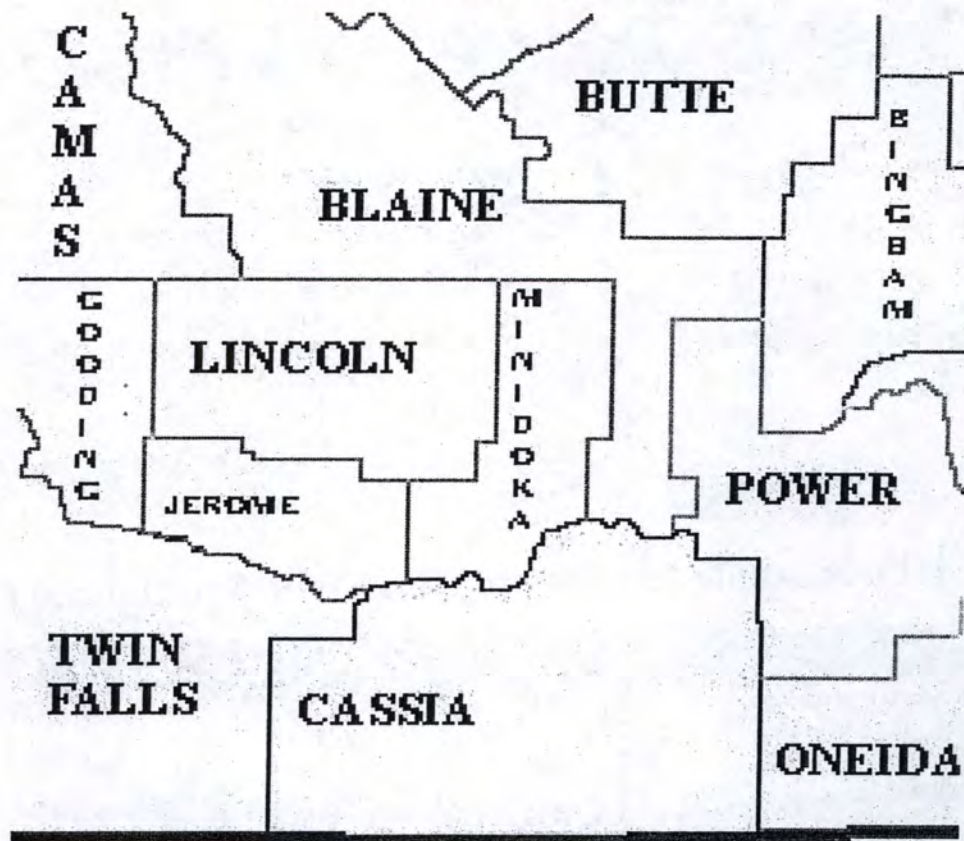


Figure 3.6  
Cassia County Economy 2001

Industry	Sales	%	Value Added	%	Employee Compensation	%	Jobs	%	Indirect Business Taxes
Agriculture/Food Processing	517,035,706	45%	113,791,151	24%	74,381,229	24%	3,150	24%	7,664,142
Mining	27,181,524	2%	17,232,699	4%	9,838,510	3%	106	1%	884,891
Construction	90,951,096	8%	29,827,344	6%	26,372,152	9%	831	6%	483,442
Manufacturing	71,588,028	6%	21,850,055	5%	16,240,708	5%	552	4%	545,761
TCPU	63,340,748	5%	26,448,081	5%	18,351,076	6%	609	5%	1,180,463
Utilities	14,881,138	1%	12,548,014	3%	3,105,430	1%	29	0%	1,906,167
Trade	100,461,678	9%	76,524,876	16%	46,721,668	15%	2,336	18%	15,270,558
FIRE	93,090,218	8%	63,689,781	13%	10,293,325	3%	690	5%	8,248,777
Services	98,039,223	8%	54,925,782	11%	47,313,170	15%	2,162	17%	1,426,627
Recreation/Eating Drinking/Lodging	20,334,700	2%	9,191,699	2%	6,435,002	2%	795	6%	1,000,109
State and Local Govt	50,114,956	4%	44,188,413	9%	39,199,718	13%	1,381	11%	0
Federal Govt	14,514,417	1%	13,640,162	3%	11,405,478	4%	335	3%	0
	1,161,533,429	100%	483,858,056	100%	309,657,467	100%	12,976	100%	38,610,939

Figure 3.7

### Total Economic Impacts of Raft River Geothermal (10MW)

Industry	Sales	Value-Added	Earnings	Jobs	Indirect Business Taxes
Agriculture/Food Processing	\$ 105,482	\$ 23,215	\$ 15,175	1	\$ 1,564
Mining	\$ 6,751	\$ 4,280	\$ 2,444	0	\$ 220
Construction	\$ 103,985	\$ 34,102	\$ 30,151	1	\$ 553
Manufacturing	\$ 86,484	\$ 26,397	\$ 19,620	1	\$ 659
TCPU	\$ 99,638	\$ 41,604	\$ 28,867	1	\$ 1,857
Utilities	\$ 5,198,587	\$ 4,383,532	\$ 1,084,853	10	\$ 665,902
Trade	\$ 155,610	\$ 118,533	\$ 72,370	4	\$ 23,653
FIRE	\$ 213,328	\$ 145,953	\$ 23,588	2	\$ 18,903
Services	\$ 205,524	\$ 115,143	\$ 99,185	5	\$ 2,991
Recreation/Eating Drinking/Lodging	\$ 46,444	\$ 20,994	\$ 14,697	2	\$ 2,284
State and Local Govt	\$ 18,960	\$ 16,718	\$ 14,830	1	\$ -
Federal Govt	\$ 8,008	\$ 7,526	\$ 6,293	0	\$ -
<b>Total</b>	<b>\$ 6,248,802</b>	<b>\$ 4,937,997</b>	<b>\$ 1,412,074</b>	<b>26</b>	<b>\$ 718,586</b>

### Total Economic Impacts of Raft River Geothermal (30MW)

Industry	Sales	Value-Added	Earnings	Jobs	Indirect Business Taxes
Agriculture/Food Processing	\$ 232,061	\$ 51,073	\$ 33,384	1	\$ 3,440
Mining	\$ 14,852	\$ 9,416	\$ 5,376	0	\$ 484
Construction	\$ 228,767	\$ 75,024	\$ 66,333	2	\$ 1,216
Manufacturing	\$ 190,266	\$ 58,073	\$ 43,164	1	\$ 1,451
TCPU	\$ 219,203	\$ 91,529	\$ 63,508	2	\$ 4,085
Utilities	\$ 11,436,892	\$ 9,643,771	\$ 2,386,677	22	\$ 1,464,984
Trade	\$ 342,343	\$ 260,774	\$ 159,213	8	\$ 52,037
FIRE	\$ 469,321	\$ 321,097	\$ 51,895	3	\$ 41,587
Services	\$ 452,153	\$ 253,316	\$ 218,207	10	\$ 6,580
Recreation/Eating Drinking/Lodging	\$ 102,177	\$ 46,186	\$ 32,334	4	\$ 5,025
State and Local Govt	\$ 41,711	\$ 36,779	\$ 32,626	1	\$ -
Federal Govt	\$ 17,618	\$ 16,557	\$ 13,844	0	\$ -
<b>Total</b>	<b>\$ 13,747,365</b>	<b>\$ 10,863,593</b>	<b>\$ 3,106,562</b>	<b>56</b>	<b>\$ 1,580,888</b>

### Total Economic Impacts of the Construction of Raft River Geothermal (10MW)

Industry	Sales	Value-Added	Earnings	Jobs	Indirect Business Taxes
Agriculture/Food Processing	\$ 298,886	\$ 65,780	\$ 42,998	2	\$ 4,430
Mining	\$ 20,121	\$ 12,757	\$ 7,283	0	\$ 655
Construction	\$ 5,566,502	\$ 1,825,530	\$ 1,614,061	51	\$ 29,588
Manufacturing	\$ 750,231	\$ 228,985	\$ 170,200	6	\$ 5,719
TCPU	\$ 399,131	\$ 166,658	\$ 115,636	4	\$ 7,438
Utilities	\$ 26,677	\$ 22,494	\$ 5,567	0	\$ 3,417
Trade	\$ 787,802	\$ 600,094	\$ 366,383	18	\$ 119,749
FIRE	\$ 507,811	\$ 347,431	\$ 56,151	4	\$ 44,997
Services	\$ 748,983	\$ 419,612	\$ 361,455	17	\$ 10,899
Recreation/Eating Drinking/Lodging	\$ 105,261	\$ 47,580	\$ 33,310	4	\$ 5,177
State and Local Govt	\$ 41,682	\$ 36,753	\$ 32,603	1	\$ -
Federal Govt	\$ 25,397	\$ 23,867	\$ 19,957	1	\$ -
<b>Total</b>	<b>\$ 8,979,598</b>	<b>\$ 3,731,761</b>	<b>\$ 2,782,606</b>	<b>105</b>	<b>\$ 227,641</b>

## Weiser - Washington County Geothermal Project

Geothermal heat can be used to dehydrate vegetables and fruits. An onion drying facility is proposed near Weiser, Idaho (Washington County). Similar facilities have been constructed in the western U.S. For example, Integrated Ingredients operates a geothermal onion and garlic drying plant in the San Emidio desert near Empire, Nevada. The geothermal facilities complex was placed in operation by OESI in 1987 (later called OESI/AMOR). It uses a well with a temperature of 266°F (130°C) pumping up to 900 gpm (57 l/s) from a reservoir.<sup>35</sup>

Washington County was founded February 20, 1879 with the county seat located at Weiser. Washington County's population was 9,924 people in 2002, or 6.8 persons per square mile. The county ranked 26<sup>th</sup> in the state in population in 2001. The State of Idaho had 15.6 persons per square mile (pqm) in 2000, Ada County had 285 pqm, and the State of New Jersey had 988 pqm, in comparison. The county is defined as 54.8% rural and 45.2% urban. Washington County's population grew 16.7% from 1990 to 2000 and declined -0.5% from 2000-2002.<sup>36</sup>

Washington County lies to the east of the State of Oregon, south of Adams County, west of Gem County, and north of Payette County (Figure 3.8). Nearly 37% of the county is owned by the federal government and 7.7% is owned by the State of Idaho. Nearly 54.9% is privately owned, which is considerable in Idaho. The State of Idaho in contrast is 63% owned by the federal government. In terms of land use, 74.4% of the county is in range lands. Nearly 14.1% lies in agriculture, most of it irrigated. The county has the 7<sup>th</sup> largest size agriculture in the state in terms of acreage (523,171 acres in farm land). Washington County ranked 20<sup>th</sup> in the state in terms of agriculture cash receipts in 1999.<sup>37</sup>

Per capita personal income in Washington County was \$16,847 per person in 2001, which was 68.7% of the state average and 55.4% of the national average. About 13% of Washington County residents were in poverty in 1999 as compared to 11.8% for the State of Idaho. In 2002, 10.4% of the county's labor force was unemployed versus 5.8% for the State of Idaho.<sup>38</sup>

### **Structure of Washington County Economy in 2001**

In terms of overall structure, agriculture and food processing was the largest economic sector employing 1,330 workers or 28% of the county's workforce (Figure 3.9). This was followed by retail and wholesale trade at 15% of the workforce, state and local government at 14%, and services at 12%. Total sales in the county were approximately \$311 million, value-added was \$169 million, employee compensation was \$106 million, total employment was 4,713, and total indirect business taxes were \$13 million. Agriculture and food processing drive Washington County's economy.

### **Economic Impacts of an Onion Drying Facility in Weiser**

The proposed Washington County onion drying facility would have about \$12.3 million in annual production costs. This would include about \$1.42 million in plant labor, \$1.8 million in depreciation and interest, \$900 thousand in research and development, \$6.5 million in general operating costs, \$1.42 million in crop hauling costs, and \$253 thousand in harvesting costs. The inputs were margined for producer prices, adjusted for imports, and entered into the economic model as reported in Figure 3.10. The majority of the production expenses would occur in the agriculture and agricultural processing economic sector or in related sectors such as transportation. The majority of the labor would be to process the onions and/or garlic. It was assumed that only 20% of the depreciation and interest expenses would be appropriated in Washington County.

The results include the direct impacts as well as the indirect and induced impacts (i.e. the multiplier effects). The onion/garlic drying facility would create \$12.2 million in annual sales, \$7.4 million in value-added, \$3.4 million in earnings, 151 jobs, and \$814 thousand in indirect business taxes. Figure 3.15 illustrates these impacts, as well as how they are distributed across all economic sectors. For example, in the jobs category the model projects 73 jobs (out of the 151 jobs) would be in the agriculture and agricultural processing industry, 33 in services, 14 in transportation, etc., and 13 jobs in retail and wholesale trade sectors.

Figure 3.8  
Washington County Region

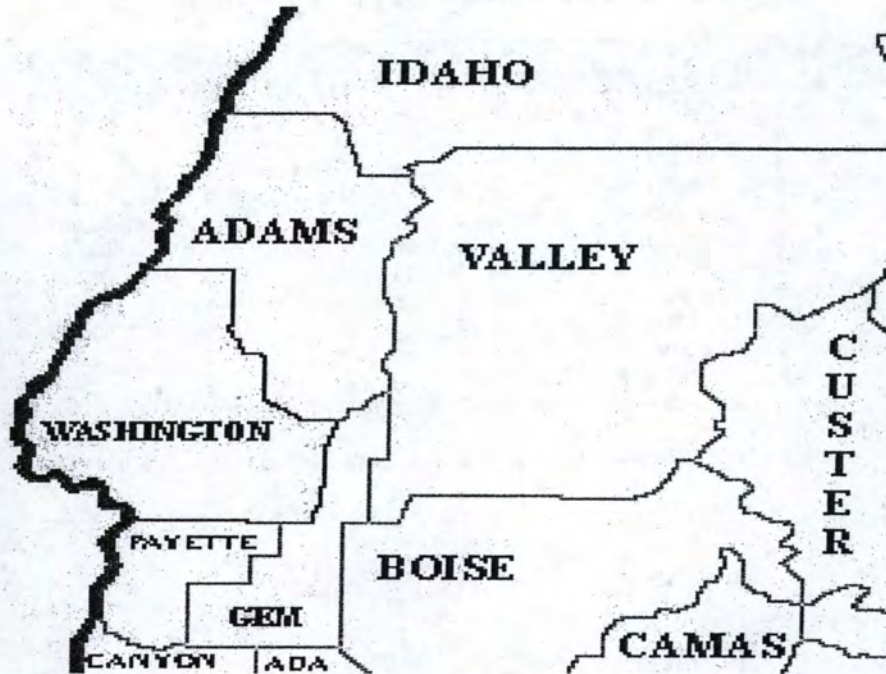


Figure 3.9  
Washington County Economy 2001

Industry	Sales	%	Value Added	%	Employee Compensation	%	Jobs	%	Indirect Business Taxes
Agriculture/Food Processing	76,673,828	25%	38,176,760	22%	24,124,656	23%	1,330	28%	2,908,760
Mining	2,254,582	1%	1,524,135	1%	582,156	1%	7	0%	89,851
Construction	33,351,109	11%	9,991,735	6%	8,830,965	8%	322	7%	162,502
Manufacturing	55,788,929	18%	23,534,710	14%	17,843,287	17%	439	9%	752,864
TCPU	23,939,285	8%	9,625,957	6%	5,087,053	5%	197	4%	741,185
Utilities	8,382,668	3%	7,068,401	4%	1,750,314	2%	12	0%	1,073,558
Trade	23,463,053	8%	17,133,006	10%	10,480,450	10%	692	15%	3,433,333
FIRE	30,171,118	10%	21,554,574	13%	2,897,448	3%	166	4%	3,041,588
Services	20,368,174	7%	12,051,467	7%	10,495,219	10%	546	12%	397,780
Recreation/Eating/Drinking/Lodging	5,505,053	2%	2,712,165	2%	1,863,438	2%	199	4%	291,089
State and Local Govt	25,419,245	8%	21,354,621	13%	17,938,610	17%	682	14%	0
Federal Govt	5,423,350	2%	4,993,766	3%	4,160,470	4%	121	3%	0
	310,740,393	100%	169,721,297	100%	106,054,065	100%	4,713	100%	12,892,510

Figure 3.10

## Total Economic Impacts of Onion Drying Facility

Industry	Sales	Value-Added	Earnings	Jobs	Indirect Business Taxes
Agriculture/Food Processing	\$ 4,224,921	\$ 2,103,636	\$ 1,329,329	73	\$ 160,280
Mining	\$ 1	\$ 1	\$ 0	0	\$ 0
Construction	\$ 151,271	\$ 45,320	\$ 40,055	1	\$ 737
Manufacturing	\$ 36,023	\$ 15,196	\$ 11,521	0	\$ 486
TCPU	\$ 1,730,600	\$ 695,872	\$ 367,749	14	\$ 53,581
Utilities	\$ 3,177,686	\$ 2,679,476	\$ 663,506	5	\$ 406,962
Trade	\$ 427,471	\$ 312,144	\$ 190,942	13	\$ 62,551
FIRE	\$ 997,020	\$ 712,282	\$ 95,748	5	\$ 100,511
Services	\$ 1,194,260	\$ 706,621	\$ 615,373	32	\$ 23,323
Recreation/Eating Drinking/Lodging	\$ 120,948	\$ 59,587	\$ 40,941	4	\$ 6,395
State and Local Govt	\$ 65,675	\$ 55,174	\$ 46,348	2	\$ -
Federal Govt	\$ 26,895	\$ 24,764	\$ 20,632	1	\$ -
<b>Total</b>	<b>\$ 12,152,770</b>	<b>\$ 7,410,073</b>	<b>\$ 3,422,143</b>	<b>151</b>	<b>\$ 814,828</b>

Figure 3.11

## Total Economic Impacts of Construction of Onion Drying Facility

Industry	Sales	Value-Added	Earnings	Jobs	Indirect Business Taxes
Agriculture/Food Processing	\$ 122,975	\$ 61,230	\$ 38,693	2	\$ 4,665
Mining	\$ 3	\$ 2	\$ 1	0	\$ 0
Construction	\$ 6,785,509	\$ 2,032,886	\$ 1,796,720	65	\$ 33,062
Manufacturing	\$ 40,090	\$ 16,912	\$ 12,822	0	\$ 541
TCPU	\$ 337,617	\$ 135,755	\$ 71,743	3	\$ 10,453
Utilities	\$ 21,744	\$ 18,334	\$ 4,540	0	\$ 2,785
Trade	\$ 682,357	\$ 498,265	\$ 304,794	20	\$ 99,849
FIRE	\$ 486,213	\$ 347,356	\$ 46,693	3	\$ 49,016
Services	\$ 529,492	\$ 313,291	\$ 272,834	14	\$ 10,341
Recreation/Eating Drinking/Lodging	\$ 78,065	\$ 38,460	\$ 26,425	3	\$ 4,128
State and Local Govt	\$ 43,800	\$ 36,796	\$ 30,910	1	\$ -
Federal Govt	\$ 23,402	\$ 21,549	\$ 17,953	1	\$ -
<b>Total</b>	<b>\$ 9,151,266</b>	<b>\$ 3,520,837</b>	<b>\$ 2,624,127</b>	<b>112</b>	<b>\$ 214,839</b>

The construction impacts of such a plant would create \$8.98 million in sales, \$9.2 million in value-added, \$2.6 million in earnings, 112 jobs, and \$.214 million in indirect business taxes. These are short-run transitory economic impacts (Figure 3.11).

### **Lava Hot Springs Geothermal Project**

Lava Hot Springs, Idaho, a small community located about thirty-five miles southeast of Pocatello, was once part of the original Fort Hall Indian Reservation (Figure 3.12). The federal government purchased the land, approximately 178 acres, as part of a treaty agreement with the Indians in the late 1800's. A 1902 Act granted the lands to the State of Idaho. The state formed the Lava Hot Springs Foundation, an agency within the Idaho Department of Parks and Recreation, to manage several hot springs on the land for public use.<sup>39</sup>

Today, the Lava Hot Springs Foundation operates a facility that features soaking pools, massage and spa facilities, an Olympic size swimming pool, a smaller lap pool, and volleyball and basketball courts (Figure 3.13). The water from a local geothermal well owned by the Foundation is used to heat the water in the swimming pools. Small on-site springs provide hot water to soaking pools, and a small on-site hot well is used to heat dressing rooms and sidewalks at the soaking pools facility.<sup>40</sup> Several other wells and springs supply hot water for hot tubs and soaking pools in private resort facilities in the community. One hotel facility utilizes geothermal water for space heating.

The Lava Hot Springs well is located approximately [1 mile east of the community center and ¼ mile west of the pool complex. Geothermal water moves through the 12-inch pipeline from the well to the swimming pool complex at a rate 350 gallons per minute (gpm), based on the pump size and information from operating personnel. Pumping capacity is controllable using a variable frequency drive responding to pipeline pressure, though it is operated manually most of the time. The temperature of the water leaving the pumping facility is approximately 114 degrees Fahrenheit, however it varies somewhat according to season and flow rate. The

geothermal water exiting the heating system is discharged into the Portneuf River just south of the Olympic Pool.

Currently, the geothermal resource provided by the Lava Hot Springs well is used to heat the two swimming pools through heat exchangers. The Olympic-sized pool has a capacity of 800,000 gallons and the smaller lap pool has a capacity of 80,000 gallons. The pool complex (composed of the Olympic-sized pool, the lap pool, and adjacent office and dressing room building) is operated from mid-May through Labor Day. The remainder of the year (defined as off-season months for the purpose of this paper), the complex remains closed.

Personnel with the Energy Division of the Idaho Department of Water Resources and with University of Idaho Extension have worked to provide the City of Lava Hot Springs and the Lava Hot Springs Foundation with technical and economic information related to further development of the local geothermal resource as proposed by the Foundation and the City. The proposed project consists of:

- enclosing the lap pool in order to operate the complex on a year-round basis;
- heating the adjacent building and new pool enclosure using geothermal energy;
- and heating the community center with geothermal energy.

Further utilization of the Lava Hot Springs well resource will be in addition to its continued use for heating the pool water at the swimming complex.

The authors of this report conducted a two part analysis of the proposed project, including:

1. evaluation of technical and economic feasibilities for each of the proposed improvements, and
2. estimation of economic impacts of completing the project.



## Technical Feasibility and Cost Analysis of Proposed Improvements

### Lava Hot Springs Pool Complex Modifications

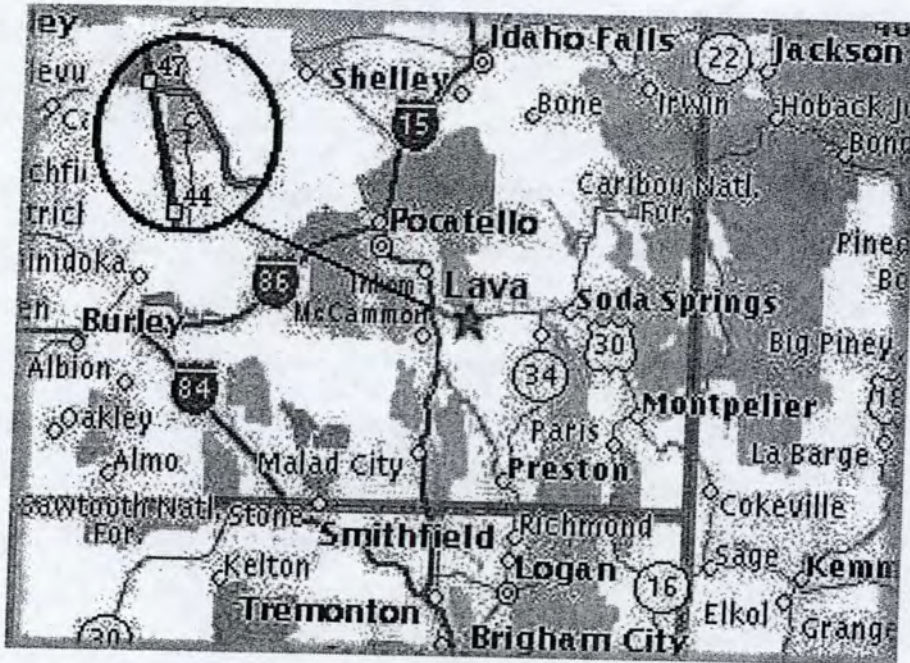
The Lava Hot Springs pool complex consists of two pools – a large Olympic sized pool with a diving platform and a smaller 75 ft x 42 ft lap pool. Adjacent to the pool is a locker room/office/mechanical building. Water, at approximately 112 degrees F (arrival temperature), is piped to the pool facility and used for heating both pools. Plate and frame heat exchangers (two for the large pool and one for the small pool) isolate the geothermal water from the pool water and facilitate more efficient chemical treatment of the pool water than would be the case if the geothermal water were used directly in the pool. A fourth heat exchanger is installed in the hot water heating loop such that geothermal heat can be used for space heating of the building. However, the space heating loop for the building is not currently functional and the building is not heated through any other means.

There is currently consideration being given to enclosing the smaller lap pool and operating that portion of the facility on a year-round basis. Should the lap pool be enclosed and operated year-round, heating the adjacent building would become necessary. Costs for enclosing the lap pool have been estimated, and a site visit was conducted on July 15, 2003 to determine the potential for restoring the existing geothermal space heating system and possibly space heating the proposed pool enclosure with geothermal energy.

### Lap Pool Enclosure: Construction Cost Analysis

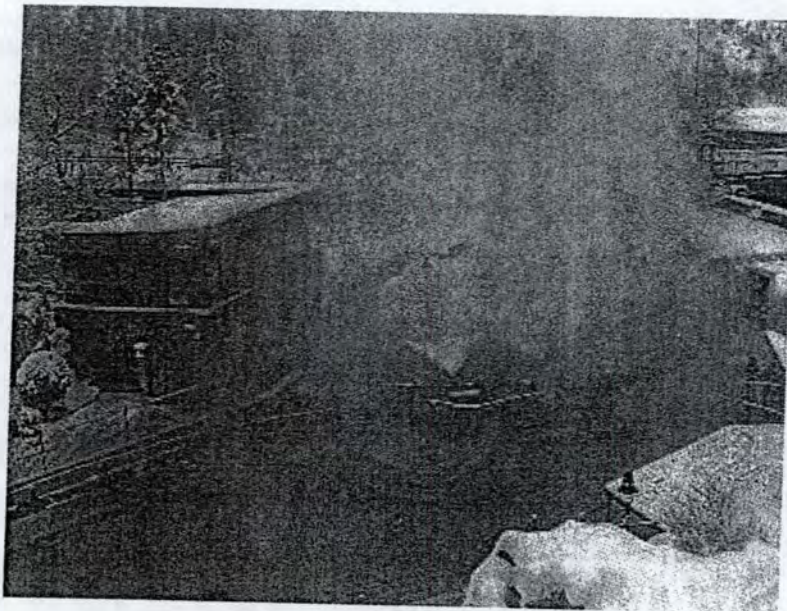
At this time the lap pool is partially enclosed by walls along the entire long dimension and part of the short dimension of the pool. Key aspects of any enclosed pool are moisture control and the avoidance of moisture induced structural damage. Generally this consists of humidity control using either ventilation air or mechanical dehumidification to remove moisture from the air. Evaporation is a strong function of pool water temperature, and the temperature to be maintained has an impact on the cost of the mechanical equipment required. For a pool of this size (75 ft x 42 ft), evaporation of approximately 250 lb per hour can be expected at a water temperature of 90°F and an air temperature of 80°F. This would

Figure 3.12



<http://www.lavahotspots.com/hotpools.html>

Figure 3.13



<http://www.lavahotspots.com/maps.html>

require a ventilation rate of approximately 6000 cubic feet per minute (cfm) at winter conditions. Two exhaust fans would remove the moisture-laden air from the building. Heating and ventilation units would provide the necessary ventilation air for the building.

**Table 3.1. Estimated Investment Costs for Proposed Conventionally Heated Pool Enclosure, Lava Hot Springs**  
*Lava Hot Springs*

<b>Cost Component</b>	<b>cost (\$)</b>
ROOF	
Removal of old roofing	\$ 1,700.00
Roofing (above average)	
<i>Heavy Composition</i>	\$ 19,800.00
<i>Insulation</i>	\$ 11,900.00
<i>Plywood Decking</i>	\$ 5,800.00
WALLS (above average)	
<i>Metal/Glass Panels</i>	\$ 28,700.00
<i>Aluminum/Steel Siding</i>	\$ 7,400.00
ELECTRICAL AND LIGHTING	\$ 36,900.00
HEATING AND VENTILATION SYSTEM	\$ 25,000.00
EXHAUST FANS (2)	\$ 4,000.00
<i>SUBTOTAL</i>	\$ 137,200.00
CONTINGENCY	\$ 25,000.00
<b><u>TOTAL COST OF ENCLOSURE</u></b>	<b><u>\$ 162,200.00</u></b>

Table 3.1 shows estimated lap pool enclosure investment costs with a traditional heating and ventilation system, based on the current architectural plans. Estimates were made using the Marshall and Swift Valuation Tool.<sup>41</sup> A significant portion of the capital costs is attributed to the heating and ventilation system because of the unique requirements of enclosed pools.

One method of determining the feasibility of a proposed project is comparing projected revenue streams to projected expenditures. Annual expenditures can be broken into two categories: annual operating and maintenance costs and annualized investment costs. Operating and maintenance costs are composed of costs associated with the operation of the pool beyond the months that the current pool complex is already open.

Investment costs consist of the actual capital investment necessary to enclose the pool and were annualized over a twenty-year period to determine annual investment costs. An interest rate of 7% was used. The annualized investment cost for enclosing the lap pool and using a conventional heating and ventilation system was estimated as \$15,310.53 (Appendix Table 1).

For the purposes of this analysis, all investment costs were annualized using a 7% interest rate and a 20-year project life. The interest rate is designed to reflect opportunity cost and time value of money. Opportunity cost is defined by economists as the cost of forgoing the next best alternative to make the chosen investment. A common tool for opportunity cost valuation is using an interest rate that is typical of an expected market return if the money had been otherwise invested. The time value of money represents the value of having money at your disposal today rather than in the future. For example, if given the choice, most people would prefer to have \$1,000 today rather than \$1,000 next year. Time value of money is also commonly defined as a percentage value of the total investment.

#### **Geothermal Space Heat Restoration in Existing Office Building: Costs and Savings**

Enclosing and operating the lap pool on a year round basis would require that the adjacent office and locker-room building be operable year-round as well. Specifically, it would require that the building be heated during off-season months. Assuming that installing a new conventional system is similar in cost to restoring the existing geothermal system, it is reasonable to assume that the geothermal system would be the most cost effective investment. This is based on the fact that there are no operational heating costs (especially gas bills) incurred and on the assumption that maintenance costs should be similar when using geothermal space heat as compared to a conventional gas heating system.

The currently nonfunctional space heating system consists of 5 individual heating units – two unit heaters in each of the dressing rooms and a larger fan coil unit serving the office and lobby area of the building. One of the unit heaters in the men’s dressing room is missing. Among the reasons reported for the abandonment of this system is freeze damage. Operating personnel reported no damage from freezing to other piping in the building, so it seems unlikely that such damage occurred to the heating system piping. However, it is possible that the coil in the large fan coil unit experienced some damage from freezing.

***Table 3.2 Lava Hot Springs Pool Building Heating System Repair Estimate***

Heat Exchanger	\$2,500
New Fan Coil Units	12,600
Circulating pump	1,600
Controls	1,000
Coil replacement	1,500
Subtotal	19,200
Contingency	3,800
Engineering	3,000
<b><i>Total</i></b>	<b><i><u>\$26,000</u></i></b>

Reestablishing the operation of this system will require the replacement of all of the four unit heaters in the locker rooms. These units are not suitable for operation with the low geothermal water temperatures available (approximately 108°F after heat exchange) and would result in unacceptably low supply air temperature to the space if used. Replacement with fan coil units with adequately designed coils (3 row minimum) would provide for satisfactory operation in these areas. The existing fan coil unit serving the office/lobby areas of the building can be retained, but the coil should be checked for adequate design and for any signs of freeze damage. Flow requirement for the system, assuming a 13°F temperature drop on the geothermal fluid, would amount to 46 gpm for the assumed 300,000 Btu/hr load.

Table 3.2 outlines the cost of the modifications required to place the geothermal heating system for the existing building back in service. This would involve replacement of the existing plate heat exchanger, replacement of the 4 existing unit heaters (assumed to be 50,000 Btu/hr capacity each – loads should be verified in the course of final design) with fan coil units, replacement of the coil in the existing fan coil unit, new controls and a new ½ horsepower (hp) circulating pump. This estimate assumes that the existing piping for the system can be re-used with only minimal replacement in the areas where the terminal unit work will be required. If the coil in the existing fan coil unit is equipped for ventilation air supply, filling the system with a water/glycol mixture would be advisable.

The investment cost of restoring the pool building geothermal space heating system was annualized over twenty years, assuming a 7% interest rate, to represent opportunity cost of the investment and time value of money. Annualized investment costs for restoring geothermal space heating to the adjacent office and dressing room building are estimated to be \$2,454.22 (Appendix Table 2).

#### **Space Heating Planned Pool Enclosure : Costs, Savings, & Other Considerations**

Utilizing geothermal space heating in order to maintain an acceptable temperature within the enclosure is also being considered. Integrating the pool enclosure geothermal space heating system with the office and dressing room building system would be efficient since both systems are necessary if the small pool is operated on a year round basis.

To determine the economic feasibility of constructing the pool enclosure, including the necessary equipment to utilize geothermal heat, projected revenue streams and cost savings should be compared to projected expenditures, composed of investment costs and operating and maintenance costs.

Investment costs include the construction costs of the enclosure, plus the incremental costs incurred by the additional investment in geothermal space heating. Using two fan coil units at 4000 cfm, each designed for a discharge air temperature of 90°F, would result in a total load of approximately 440,000 Btu/hr. Based on an 18°F temperature drop on the loop, this would require a loop flow of 49 gpm necessitating 2 ½" piping for the main supply and return lines. Depending on the construction of the building, actual heating load may be different than the assumed value in these calculations, but this should not substantially impact equipment costs.

Table 3.3 outlines investment costs of constructing the pool enclosure plus the incremental costs associated with connecting the pool enclosure heating system to the locker room building system. Again, investment costs were annualized over a twenty-year period, assuming a 7% interest rate. The investment cost is estimated to be \$187,400, resulting in an annualized investment cost of \$17,689.23 (Appendix Table 3).

Maintenance costs may vary slightly for this scenario due to the change in capital equipment and associated maintenance costs necessary for geothermal space heating. This factor has not been included in the analysis because the variation in costs should not be significant, as maintenance is already performed on geothermal equipment used to heat pool water and it is difficult to accurately predict what the difference in maintenance costs would be from a traditional heating system. Furthermore, it is equally possible that adding a geothermal space heating system would result in a net reduction of maintenance performed on heating systems, rather than increase maintenance requirements.

Operating costs should be significantly less than in the first scenario. Annual fuel (gas) costs using a traditional heating and ventilation system in the pool enclosure are estimated to be \$15,643.35 each year (Appendix Figure 1). These costs can be entirely avoided by utilizing geothermal space heating, resulting in a heating cost savings of \$15,643.35 annually.

To determine which enclosure makes the most economic sense, heating cost savings should be compared to the estimated additional annual investment cost associated with constructing an enclosure that utilizes geothermal space heat rather than a conventional heating and ventilation system. To find the additional investment cost associated with geothermal space heating the pool enclosure, the investment

**Table 3.3. Estimated Investment Costs for Proposed Geothermal Heated Pool Enclosure, Lava Hot Springs**

Cost Component	cost (\$)
ROOF	
Removal of old roofing	\$ 1,700.00
Roofing (above average)	
<i>Heavy Composition</i>	\$ 19,800.00
<i>Insulation</i>	\$ 11,900.00
<i>Plywood Decking</i>	\$ 5,800.00
WALLS (above average)	
<i>Metal/Glass Panels</i>	\$ 28,700.00
<i>Aluminum/Steel Siding</i>	\$ 7,400.00
ELECTRICAL AND LIGHTING	\$ 36,900.00
EXHAUST FANS (2)	\$ 4,000.00
GEOHERMAL INCREMENTAL COSTS	
<i>Heating and Ventilation Units (2)</i>	\$ 30,000.00
<i>Piping</i>	\$ 4,000.00
<i>Heat Exchanger</i>	\$ 2,600.00
<i>Antifreeze</i>	\$ 600.00
<i>Controls</i>	\$ 4,000.00
<b>SUBTOTAL</b>	<b>\$ 157,400.00</b>
CONTINGENCY	\$ 25,000.00
ENGINEERING	\$ 5,000.00
<b><u>TOTAL COST OF ENCLOSURE</u></b>	<b><u>\$ 187,400.00</u></b>

cost for the conventionally heated enclosure was subtracted from the investment cost for the geothermal space heated enclosure. The additional investment cost is estimated to be \$25,200 or an additional annualized cost of \$2378.70. The additional annualized investment cost for including a geothermal



---

space heating system is compared to the annual heating cost savings of \$15,643.35, resulting in an estimated annual net savings of \$13,264.65. The availability of the geothermal resource for heating of ventilation air in winter conditions (normally a costly operational issue) makes this option more attractive than it would be in a conventionally fuelled facility.

### **Swimming Pool Complex Project Feasibility and Conclusions**

Utilizing geothermal space heating rather than a conventional heating and ventilation system was selected for the pool enclosure based on the assumption that net annual savings (composed of avoided annual heating costs less annual additional investment costs) are generated. In fact, annual savings of utilizing the geothermal space heating and ventilation system are estimated to be \$13,264.65. Enclosing the pool and equipping it with a geothermal space heating and ventilation system would require an investment of \$187,400. Additionally, operating the pool on a year-round basis requires the pool building to remain open and heated. The investment cost of restoring the existing geothermal system is \$26,000. This results in a total investment cost for the pool complex modifications of \$213,400. The annual investment cost is equal to \$20,143.45, based on a 7% interest rate and a twenty-year investment period (Appendix Table 4).

For this project to be considered economically feasible, the annual investment cost of \$20,143.45, plus any operating costs (wages, "lights", laundry, etc.) and maintenance costs associated with keeping the lap pool open in off-season months must be covered. The most obvious source of revenues to cover these costs is revenue generated by admission sales in off-season months.

If estimated revenue streams from additional admission sales fall short of covering additional annual expenditures (investment costs, operating and maintenance costs attributed to enclosing the lap pool and operating it on a year-round basis), alternative revenue sources could be explored. If the community determines that having the pool open on a year-round basis is of benefit to the community as a whole, a portion of local taxes might be designated to the project. Also, it is possible that having the enclosed *and* geothermally heated complex open on a year round basis might provide unique opportunities for securing government and foundation grants that would make the project economically feasible. The ability of stakeholders (Lava Hot Springs Foundation, Lava Hot Springs community, local government)

to identify potential sources of alternative revenues, and to secure such funding, will likely be crucial to the economic success of the project.

### **Geothermal Space Heating Community Center**

The Lava Hot Springs Community Center building was constructed in 1936 and is heated primarily by two Carrier condensing type gas furnaces located in a basement utility room. The furnaces operate in parallel on a common duct system and have a combined rate capacity of 186,000 Btu/hr output, but the actual capacity due to elevation is likely somewhat less than this figure. There are gas log units installed in fireplaces at 3 locations in the building but it is unknown the extent to which these are used for space heating. The main floor of the building includes a 2,625 square foot main hall and 1,400 square feet in the two wings. A basement, which appears to be used primarily for storage, adds another 1,400 square feet. The Community Center is located within approximately 100 ft of the existing pipeline delivering water from the hot springs to the community pool. However, a pipeline from the existing hot water pipe to the Community Center would be under an existing paved road.

Geothermal applications such as heating the Community Center normally involve the installation of hot water coils in the existing ductwork and the use of the existing furnace fans to provide air flow. In this case, the available water temperature is quite low and assuming a temperature of 110°F arriving at the mechanical room, there is insufficient temperature to permit the use of an isolation heat exchanger (due to temperature loss associated with the heat exchanger) between the geothermal water and the coils in the ductwork. Using the geothermal water directly in the coils does present the prospect of potential fouling due to scaling and/or corrosion, however the water chemistry does not appear to be particularly problematic.

Based on the water temperature of 110°F, 3 row coils could produce supply air temperatures of approximately 100°F to the space. This value is substantially less than the supply air temperature currently being delivered by the furnaces (likely in the range of 115° to 135°F). As a result, the capacity of the system available for geothermal operation will be less than that of the current system. At the 100°F supply air temperature and an air flow in the middle of the range of which the furnaces are

capable (the added resistance of the coils would preclude operation at peak air flow rates), the expected maximum capacity available would be approximately 80,000 Btu/hr. Assuming that the existing furnaces are sized for the actual heating load of the building and that their rated capacity is decreased by 5% due to the elevation, the geothermal system would have a capacity of approximately 45% that of the existing system. Several options are possible to address the capacity deficit, including the following:

1. retrofit coils in the supply air ductwork and operate the geothermal heating as a first stage in a 2-stage system in which all heating at lower outside temperatures is provided by the existing gas furnaces
2. retrofit coils in the return air ductwork and operate the geothermal system as the first stage of a 2-stage system in which both the geothermal coils and the furnaces operate at lower outdoor air temperatures.
3. Retrofit coils in the existing furnaces to provide a portion of the heating capacity and add additional geothermally supplied fan coil heating units to the building to provide the necessary additional capacity.

Energy savings would vary with Option 1 capturing the least savings and Option 3 the most savings (virtually all existing space heating by geothermal). Retrofit costs for Options 1 and 2 would be similar. Option 3 would cost much more than the other two options. The system layouts for all options are similar (Appendix Figure 2).

#### **Retrofit Options Considerations, Costs and Savings**

*Option 1* would involve the installation of new hot water coils in the existing supply air ductwork near the outlet of the furnaces. Space is very limited, and to accommodate the required coil area (4 sq ft coil face area each), it may be necessary to place the coils in the ductwork at an angle. During the site visit an installation immediately at the outlet of the furnaces was envisioned. Calculations indicate, however, that there is insufficient duct cross section in this location.

Provided verification of adequate space for installation, two individual coils or a single larger coil would be placed in the ductwork. A 3-row configuration at 12 fins/inch would be capable of generating 100°F supply air temperature. The coil(s) would provide all heating needs down to a temperature of approximately 40°F (30°F in night setback mode) below which an outdoor thermostat would deactivate the geothermal system and the gas burners in the existing furnaces would be enabled. At all temperatures below 40°F, the gas burners would handle the load. Water would be delivered from the existing hot springs line through new 1 ½" buried supply line at a flow of 16 gpm. This line could be constructed of either pre-insulated PVC or pre-insulated polyethylene pipe. A ¼ hp circulating pump would provide flow through the 1 ½" line to the coils. Water (at 100°F) from the coil(s) would be returned to the main hot springs line through a second 1 ½" line.

Based on the capacity of the geothermal hot water coils and the existing furnaces, this arrangement would be capable of displacing approximately 50% of the existing annual heating needs of the building. The gas system would meet the remaining 50%.

Costs for this option are outlined in Table 3.4. The largest uncertainty in the cost is associated with the manner in which the geothermal lines serving the building will be installed under the road. The table costs assume the ability to "cut" the pavement and trench across the road. If horizontal boring under the road should be required, costs would increase by approximately \$4000 to \$5000. In addition, the space limitations in the furnace room could impact costs depending upon the specifics of the coil installation, though a generous allowance has been included in the estimate for labor associated with this task.

Assuming the uncertainties mentioned above do not affect costs, the estimated annualized investment cost of the Option 1 retrofit (over 20 years at 7%) is \$1,887.86 per year. As mentioned above, fuel needs after the retrofit will only be about 50% of the current fuel needs. So based on current gas usage in the Community Center and projected gas prices, continued conventional fuel needs will be an estimated \$675.21 annually (Appendix Figure 3). This results in an estimated total annual cost of \$2,563.07 annually or an additional annual cost of \$1,212.65 if Option 1 is adopted.

*Option 2* would be very similar to Option 1 in terms of the installation. The primary difference would be the location of the new hot water coils. In this case the coils would be installed in the return air duct adjacent to the furnaces. In this location, the coils would provide a capacity just slightly less than in Option 1 (due to the reduced fan performance handling heated air) but would be able to operate in conjunction with the furnace burner at lower outside temperature conditions. A two-stage thermostat would control the system in such a way as to enable the gas burners when the geothermal system could no longer meet the load. As a result of this capability, the savings under this option would amount to approximately 80% of existing annual gas space heating energy use.

**Table 3.4. Lava Hot Springs Community Center Estimated Installation Costs: Options 1 and 2**

Hot water coils	\$ 4,000
1 1/2" buried lines to building	7,300
1 1/2" lines in building	2,500
Circulating pump	1,000
Misc mechanical and electrical	200
<i>Subtotal</i>	<i>15,000</i>
Contingency	2,000
Engineering	3,000
<b><u>Total</u></b>	<b><u>\$ 20,000</u></b>

The installation of the hot water coils in the return air duct would be advantageous since the cost would be the same as for the supply air installation and the savings substantially greater. With the return air location, air entering the existing furnace fans would be 100°F. This has three implications in terms of system operation. The mass flow of the fans would be reduced due to the lower density of the air – thus reducing heating capacity; the cooling of the fan motors would be reduced due to the higher temperature air; and finally it would be necessary to limit the supply air temperature during combined operation (geothermal and gas). Coil design could be adjusted (fin spacing, surface area) to compensate for the reduced air

density. Similar return air installations have been made without adverse impact on the fan motors, but they should be checked for allowable temperature rise in the course of final design. The supply air temperature could be controlled by increasing airflow to the maximum or by de-rating the burners in the furnace.

As mentioned earlier, the return duct installation was not evaluated during the site visit and to the extent that space is available for coil installation, the retrofit cost would be essentially the same as for the supply air installation of Option 1. The only difference would be a small incremental cost of somewhat more effective hot water coils – a value smaller than the error margin of this estimate.

Assuming the specified uncertainties do not affect costs, the annualized investment cost of the Option 2 retrofit (over 20 years at 7% interest) is the same as for Option 1, \$1,887.56 per year (Appendix Table 5). However, estimated fuel cost savings are greater under Option 2: \$1,080.34 annually compared with \$675.21 annually (Appendix Figure 3). The remaining annual conventional fuel costs are estimated to be \$270.08. This results in an estimated total annual cost of \$2,157.94 or an additional cost of \$807.52 annually if Option 2 is adopted.

**Option 3** would involve the same basic installation as described in Option 1 plus some additional equipment to provide for the unmet portion of the heating requirement. Assuming that the existing duct system would permit the air flow from the existing furnaces to be directed primarily to the basement and the two wings of the building, two new fan coil units could be installed in the main hall to provide the additional capacity required.

Using two fan coil units at 50,000 Btu/hr each, the capacity of the geothermal system would match that of the existing gas furnaces. These units could be suspended from the ceiling in the main hall, or space permitting, concealed in adjacent rooms and ducted to the main hall. The lower cost suspended option was used to develop the cost estimate for the table below. Adding the two fan coil units would raise the geothermal flow requirement to 36 gpm and this would necessitate the use of 2" pipe for the supply and return lines to the building, and an increase in pump size to 1/3hp. The ability to meet 100% of the heating needs of the building would allow the system outlined here to displace 100% of the existing space heating energy consumption of the building. Installation costs for Option 3 are presented in Table 3.5. Estimated

annualized investment cost of the Option 3 retrofit is \$2,831.79 per year. Under this system, there would be no conventional heating fuel needs. Therefore, the estimated total annual cost is equal to the annual investment cost of \$2,831.79. The additional annualized costs of adopting Option 3 would be \$1,481.37.

***Table 3.5 Lava Hot Springs Community Center Estimated Installation Costs: Option 3***

Hot water coils	\$4,000
Fan coil units	6,300
2" buried lines to building	8,000
2" lines in building	2,700
Circulating pump	1,600
Misc mechanical and electrical	200
<i>Subtotal</i>	<i>22,800</i>
Contingency	3,400
Engineering	3,800
<b><u>Total</u></b>	<b><u>\$30,000</u></b>

**Impact of Community Center on Hot Springs Line**

Heating of the community center should have little if any impact on the operation of the pool since the space heating of the building will peak during the winter months when the pool is not in operation. Even if the smaller pool is operated in the winter months the impact of the community center on the heat available from the hot springs line would be minimal. The line is estimated to carry 350 gpm at a temperature of 114°F. Using this water to primarily heat a pool and adjacent locker rooms, it should be possible to reduce the water to approximately 90°F with the combined loads. This would amount to an available capacity of 4,200,000 Btu/hr. The maximum load the Community Center would impose (Option 3) would amount to 180,000 Btu/hr or about 4% of the heat available from the line.

---

### **Community Center Project Conclusions and Recommendations**

According to estimates presented in this report, none of the options identified as technically feasible for retrofitting the Community Center to utilize geothermal space heating will “pay their own way.” They would result in increased annual heating costs (both investment and operational) from as little as \$807.52 per year to as much as \$1,418.37 per year. Lava Hot Springs decision-makers should consider how these costs would be covered before retrofitting the Community Center to heat it with geothermal energy. Also, they should consider the uncertainties associated with such “change-overs” before making a final decision.

### **Adequacy of Resource**

Operation of the smaller pool and the heating of the pool building during the winter months will impose new loads on the geothermal fluid but these are well within the capacity of the existing resource, pump and pipeline.

Based on an assumed arrival temperature (at the pool facility) of 112°F, the total flow required for the pool building heating system will amount to approximately 46 gpm. Flow requirement for the pool enclosure heating and ventilation system would peak at 49 gpm based on the assumptions outlined above. This would leave a total of more than 250 gpm for the heating of the pool. Assuming a temperature drop of 15°F on the pool heat exchanger, the flow requirement for pool heat would amount to only 43 gpm. This results in a total geothermal requirement for heating of approximately 138 gpm of the available 350 gpm.

## **Potential Impacts on the Lava Hot Springs Economy**

### **General Characteristics of the Bannock County Economy**

Lava Hot Springs is located just south of Pocatello in Bannock County. Bannock County had a population of 75,804 people in 2002, with a density of 68.1 persons per square mile (ppm). The county ranked 5<sup>th</sup> in the state in population among counties in 2001. The State of Idaho had 15.6 ppm in 2000; Ada County had 285 ppm; and the State of New Jersey had 988 ppm in comparison. The



county is defined as 82.7% urban, one of the most urban in the state. Bannock County's population grew 14% from 1990 to 2000, and 0.3% from 2000 to 2002.

The largest city of Bannock County is Pocatello (51,442 people) followed by Chubbuck (9,700), McCammon (805), Inkom (738), Downey (613), Lava Hot Springs (521), and Arimo (348) in 2000. Bannock County lies south of Bingham County, west of Caribou and Bear Lake Counties, north of Franklin County, and east of Power County.<sup>42</sup> The federal government owns only 31% of the county and 6.7% is owned by the State of Idaho. Over 60% of the county is privately owned. In terms of land use, 46.4% of the county is in rangeland, 32% is in agriculture and 16% is in forest. The county has the 14<sup>th</sup> largest agricultural sector in the state in terms of acreage (358,189 acres in farm land).<sup>43</sup>

Bannock County per capita personal income was \$21,780 in 2001, which was 89% of the state average and 72% of the national average. Almost 14% of the population was in poverty in 1999 as compared to 11.8% for the State of Idaho. In terms of unemployed, 6.4% of the county's labor force was unemployed in 2002 versus 5.8% of the labor force for the State of Idaho.<sup>44</sup>

In 2001, services was the largest sector in the Bannock County economy employing 10,388 workers or 24% of the county's workforce. This was followed by state and local government at 18% of the workforce, and trade at 17% (Figure 3.15). Total sales in the county were approximately \$3.078 billion, value-added was \$1.7 billion, employee compensation was \$1.1 billion, total employment was 42,498 and total indirect business taxes were \$123 million.

### **Local Economic Impacts of Lava Hot Springs Geothermal Development Plans**

The economic impacts that would be attributable to the planned geothermal development discussed in this report would be those associated with keeping the Lava Hot Springs lap pool open during the entire year, rather than just in the summer. Geothermal development associated with heating the community center would impact the budget of the senior citizens group that pays the heating bill, but would not appreciably impact jobs or income in the community.

Figure 3.14  
South-East Idaho Region

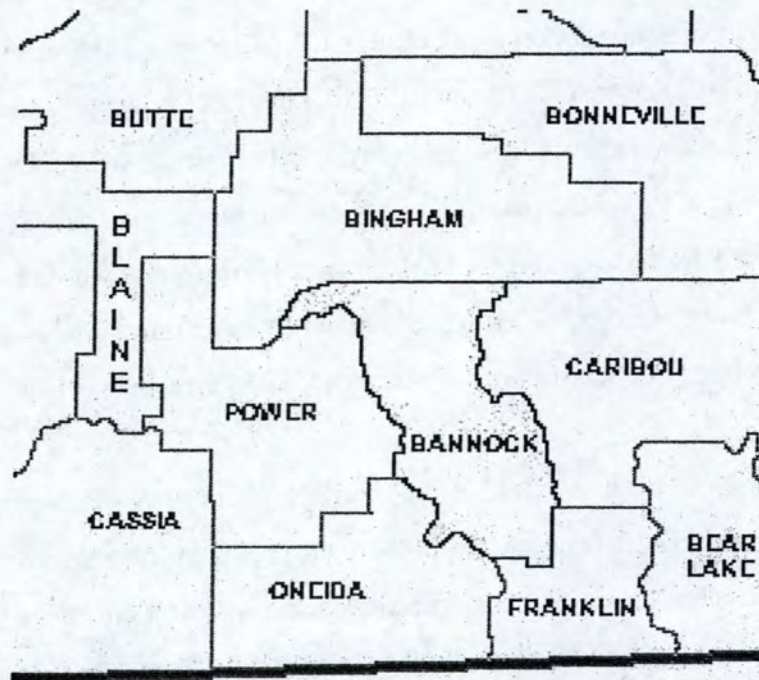


Figure 3.15  
Bannock County Economy 2001

Industry	Sales	%	Value Added	%	Employee Compensation	%	Jobs	%	Indirect Business Taxes
Agriculture/Food Processing	217,334,091	7%	73,064,562	4%	46,366,238	4%	1,816	4%	3,763,571
Mining	32,645	0%	21,639	0%	13,354	0%	1	0%	1,032
Construction	347,549,622	11%	115,570,576	7%	102,137,527	9%	3,149	7%	1,881,944
Manufacturing	452,035,309	15%	187,120,280	11%	119,273,360	11%	2,401	6%	3,871,742
TCPU	185,141,800	6%	55,285,423	3%	34,377,173	3%	1,813	4%	4,160,663
Utilities	101,927,307	3%	61,636,401	4%	16,516,222	1%	147	0%	9,945,214
Trade	329,118,286	11%	247,321,602	15%	150,803,562	14%	7,282	17%	49,569,489
FIRE	407,050,751	13%	277,657,863	16%	61,749,457	6%	2,577	6%	35,109,180
Services	556,626,343	18%	283,478,021	17%	238,184,959	22%	10,388	24%	7,530,175
Recreation/Eating/Drinking/Lodging	125,608,932	4%	59,038,438	3%	41,370,631	4%	4,089	10%	6,816,247
State and Local Govt	305,769,012	10%	285,948,841	17%	254,668,259	23%	7,830	18%	0
Federal Govt	49,858,067	2%	45,116,108	3%	38,841,339	4%	1,000	2%	0
	3,078,052,165	100%	1,691,259,753	100%	1,104,302,082	100%	42,495	100%	122,649,257

Figure 3.16

## Total Economic Impacts of Lava Hot Springs Geothermal

Industry	Sales	Value-Added	Earnings	Jobs	Indirect Business Taxes
Agriculture/Food Processing	\$ 581	\$ 195	\$ 124	0 \$	10
Mining	\$ 0	\$ 0	\$ 0	0 \$	0
Construction	\$ 3,019	\$ 1,004	\$ 887	0 \$	16
Manufacturing	\$ 7,166	\$ 2,967	\$ 1,891	0 \$	61
TCPU	\$ 8,630	\$ 2,577	\$ 1,602	0 \$	194
Utilities	\$ 1,989	\$ 1,203	\$ 322	0 \$	194
Trade	\$ 12,200	\$ 9,168	\$ 5,590	0 \$	1,838
FIRE	\$ 17,363	\$ 11,843	\$ 2,634	0 \$	1,498
Services	\$ 29,468	\$ 15,008	\$ 12,610	1 \$	399
Recreation/Eating Drinking/Lodging	\$ 61,501	\$ 28,907	\$ 20,256	2 \$	3,337
State and Local Govt	\$ 1,703	\$ 1,593	\$ 1,419	0 \$	-
Federal Govt	\$ 958	\$ 867	\$ 747	0 \$	-
<b>Total</b>	<b>\$ 144,579</b>	<b>\$ 75,331</b>	<b>\$ 48,082</b>	<b>3 \$</b>	<b>7,547</b>

Lava Hot Springs decision makers have estimated new staff required to keep the lap pool open through the entire year would equate with 1 and ½ more jobs. Results of the economic model used in this analysis indicate that these jobs would result in the following Bannock County impacts, most of which would occur in Lava Hot Springs (Figure 16):

- Total jobs – 3 (1½ jobs at the pool plus 1½ additional jobs in the county economy).
- Earnings (wages and salaries of workers and profits of proprietors) — \$48,000.
- Annual sales or gross revenues of business firms — \$145,000.
- Value-added — \$75,000.
- Indirect business taxes — \$7,500.

These impacts are conservative, because they do not account for the likelihood that keeping the lap pool open on a year-round basis (8½ additional months) will bring more winter visitors to Lava Hot Springs. More winter visitors mean more local economic activity. Even so, the economic impacts, as estimated, are meaningful in a small town such as Lava Hot Springs where new jobs will probably go to local residents who are currently unemployed.

## Conclusions

The state of Idaho has substantial geothermal resources. However, except for direct use to heat buildings, homes, and businesses the resource is largely underdeveloped. This report provides information about the economic benefits that would be created from several different scenarios for further developing geothermal energy in Idaho. The types of geothermal development analyzed in this study could be located in other areas where similar geothermal resources are available. The impacts of geothermal development at such other locations would be similar to those reported herein. Such development would mean more jobs and income to Idaho's residents. Most of the potential geothermal developments in Idaho would be in rural areas. These regions are especially in need of economic development. Thus new jobs and income from geothermal development could greatly benefit rural Idaho.



## References

- <sup>1</sup> Energy Information Agency, U.S. Department of Energy.
- <sup>2</sup> World Bank, <http://devdata.worldbank.org/data-query/>
- <sup>3</sup> See *Julian Simon's Bet With Paul Ehrlich*, Overpopulation.com, [http://www.overpopulation.com/faq/People/julian\\_simon.html](http://www.overpopulation.com/faq/People/julian_simon.html)
- <sup>4</sup> Stephen Moore, Julian Simon Remembered: It's a Wonderful Life, Cato Institute, April 1998, [http://www.cato.org/pubs/policy\\_report/cpr-20n2-1.html](http://www.cato.org/pubs/policy_report/cpr-20n2-1.html).
- <sup>5</sup> History of the Origins of the U.S. Department of Energy, U.S. Department of Energy, [http://ma.mbe.doe.gov/me70/history/DOE's\\_history.htm](http://ma.mbe.doe.gov/me70/history/DOE's_history.htm).
- <sup>6</sup> What History Can Teach us about Forecasts of Energy Use?, Allan Chen, <http://www.lbl.gov/Science-Articles/Archive/EETD-energy-forecasting.html>
- <sup>7</sup> Energy Information Agency, U.S. Department of Energy
- <sup>8</sup> National Energy Policy, Report of the National Energy Policy Development Group, May 2001. <http://www.whitehouse.gov/energy/>
- <sup>9</sup> Columbia River System Operation Review, Final Environmental and Impact Statement, Main Report, U.S. Army Corps of Engineers, November 1995.
- <sup>10</sup> *Scientists predict global warming deluge in Bangladesh*, ABC News Online, 4/10/03 [http://www.abc.net.au/science/news/scitech/SciTechRepublish\\_829292.htm](http://www.abc.net.au/science/news/scitech/SciTechRepublish_829292.htm)
- <sup>11</sup> *Bush firm over Kyoto stance*, CNN.com, 3/29/01, <http://www.cnn.com/2001/U.S./03/29/schroeder.bush/>
- <sup>12</sup> Energy Information Agency, U.S. Department of Energy.
- <sup>13</sup> Focus on Renewable Energy, World Energy Council, <http://www.worldenergy.org/wec-geis/focus/renew/ser.asp>.
- <sup>14</sup> Bonneville Power Administration, Keeping Current: The Value of the Columbia River [http://www.bpa.gov/Corporate/KC/home/keeping/98kc/kc\\_valuex.shtml](http://www.bpa.gov/Corporate/KC/home/keeping/98kc/kc_valuex.shtml)
- <sup>15</sup> A History of Renewable Energy in the U.S., Geothermal Energy Program, U.S. Department of Energy, <http://www.eere.energy.gov/geothermal/>.
- <sup>16</sup> Geothermal Education Office, 664 Hilary Drive, Tiburon, CA 94920, <http://geothermal.marin.org/GEOpresentation/>
- <sup>17</sup> Idaho Geothermal Resources, Idaho Department of Water Resources, <http://www.idwr.state.id.us/GeoThermal/default.htm>.
- <sup>18</sup> Geothermal Aquaculture Research Foundation, Inc. 1321 Warm Springs Ave. Boise Idaho 83712, U.S.A. Email: [leroy@garf.org](mailto:leroy@garf.org).
- <sup>19</sup> Geothermal energy, The World Bank Group, <http://www.worldbank.org/html/fpd/energy/geothermal/applications.htm>.
- <sup>20</sup> Geothermal Education Office, 664 Hilary Drive, Tiburon, CA 94920, <http://geothermal.marin.org/GEOpresentation/>
- <sup>21</sup> Geothermal Education Office, <http://geothermal.marin.org/geoenergy.html>
- <sup>22</sup> Geothermal Energy, U.S. Department of Energy, Renewables, Energy Information Agency, <http://www.eia.doe.gov/cneaf/solar.renewables/page/geothermal/geothermal.html>.
- <sup>23</sup> Regional Economic Information System (REIS), U.S. Bureau of Economic Analysis.
- <sup>24</sup> Robison, M. Henry, Charles W. McKetta and Steven S. Peterson, "A Study of the Effects of Changing Timber Policies on Rural Communities in North Central Idaho," CBDR, University of Idaho, February 1996.

### References Continued

- <sup>25</sup> *Statistical Abstract of the United States*, U.S. Bureau of the Census, 2001
- <sup>26</sup> *Profile of Rural Idaho*, Idaho Economic Development Division, 1999.
- <sup>27</sup> Bureau of the Census, U.S. Department of Commerce.
- <sup>28</sup> Minnesota IMPLAN Group, 1725 Tower Drive West Suite 140, Stillwater, MN 55082.
- <sup>29</sup> County Profiles of Idaho, Idaho Department of Commerce, 2001
- <sup>30</sup> Access Idaho, <http://www.accessidaho.org/aboutidaho/county>
- <sup>31</sup> Regional Economic Information System (REIS), U.S. Bureau of Economic Analysis.
- <sup>32</sup> Access Idaho, <http://www.accessidaho.org/aboutidaho/county>
- <sup>33</sup> Regional Economic Information System (REIS), U.S. Bureau of Economic Analysis.
- <sup>34</sup> County Profiles of Idaho, Idaho Department of Commerce, 2001.
- <sup>35</sup> Small Geothermal Power Project Examples, John W. Lund, Tonya "Toni" Boyd, [http://www.geothermie.de/egec-geothernet/prof/small\\_geothermal\\_power.htm](http://www.geothermie.de/egec-geothernet/prof/small_geothermal_power.htm)
- <sup>36</sup> Access Idaho, <http://www.accessidaho.org/aboutidaho/county/washington.html>
- <sup>37</sup> Regional Economic Information System (REIS), U.S. Bureau of Economic Analysis.
- <sup>38</sup> County Profiles of Idaho, Idaho Department of Commerce, 2001.
- <sup>39</sup> Lava Hot Springs Foundation, <http://www.lavahotsprings.com/history.html>
- <sup>40</sup> Lava Hot Springs Foundation, <http://www.lavahotsprings.com/history.html>
- <sup>41</sup> Marshall Valuation Service. Marshall & Swift, L.P. 2003 <http://www.marshallswift.com>.
- <sup>42</sup> Access Idaho, <http://www.accessidaho.org/aboutidaho/county>
- <sup>43</sup> Regional Economic Information System (REIS), U.S. Bureau of Economic Analysis.
- <sup>44</sup> County Profiles of Idaho, Idaho Department of Commerce, 2001.

**APPENDIX TABLES**

- Table 1.** Conventionally Heated Pool Enclosure: Annualized Investment Cost
- Table 2.** Geothermal Space Heating Restoration for Adjacent Office Building: Annualized Investment Cost
- Table 3.** Geothermal Heated Pool Enclosure: Annualized Investment Cost
- Table 4.** Proposed Pool Complex Modifications: Annualized Investment Cost
- Table 5.** Community Center Geothermal Retrofit Options 1 & 2: Annualized Investment Cost
- Table 6.** Community Center Geothermal Retrofit Option 3: Annualized Investment Cost

**APPENDIX FIGURES**

- Figure 1.** Geothermal Heating Considerations for Proposed Lava Hot Springs Pool Enclosure
- Figure 2.** Community Center: Geothermal Retrofit Installation Layout for All Options
- Figure 3.** Geothermal Retrofit Considerations for Lava Hot Springs Community Center



TABLE 1. CONVENTIONALLY HEATED POOL ENCLOSURE: ANNUALIZED INVESTMENT COST

Time Period	Investment	Interest Rate	Interest Accrued	Contribution to Investment	Interest Cost	Total Annual Cost	Remaining Investment Cost
0	\$ 162,200.00	7%				\$ -	\$ 162,200.00
1	\$ 162,200.00	7%	\$ 11,354.00	\$ 3,956.53	\$ 11,354.00	\$ 15,310.53	\$ 158,243.47
2	\$ 158,243.47	7%	\$ 11,077.04	\$ 4,233.49	\$ 11,077.04	\$ 15,310.53	\$ 154,009.98
3	\$ 154,009.98	7%	\$ 10,780.70	\$ 4,529.83	\$ 10,780.70	\$ 15,310.53	\$ 149,480.14
4	\$ 149,480.14	7%	\$ 10,463.61	\$ 4,846.92	\$ 10,463.61	\$ 15,310.53	\$ 144,633.22
5	\$ 144,633.22	7%	\$ 10,124.33	\$ 5,186.21	\$ 10,124.33	\$ 15,310.53	\$ 139,447.01
6	\$ 139,447.01	7%	\$ 9,761.29	\$ 5,549.24	\$ 9,761.29	\$ 15,310.53	\$ 133,897.77
7	\$ 133,897.77	7%	\$ 9,372.84	\$ 5,937.69	\$ 9,372.84	\$ 15,310.53	\$ 127,960.08
8	\$ 127,960.08	7%	\$ 8,957.21	\$ 6,353.33	\$ 8,957.21	\$ 15,310.53	\$ 121,606.76
9	\$ 121,606.76	7%	\$ 8,512.47	\$ 6,798.06	\$ 8,512.47	\$ 15,310.53	\$ 114,808.70
10	\$ 114,808.70	7%	\$ 8,036.61	\$ 7,273.92	\$ 8,036.61	\$ 15,310.53	\$ 107,534.77
11	\$ 107,534.77	7%	\$ 7,527.43	\$ 7,783.10	\$ 7,527.43	\$ 15,310.53	\$ 99,751.68
12	\$ 99,751.68	7%	\$ 6,982.62	\$ 8,327.92	\$ 6,982.62	\$ 15,310.53	\$ 91,423.76
13	\$ 91,423.76	7%	\$ 6,399.66	\$ 8,910.87	\$ 6,399.66	\$ 15,310.53	\$ 82,512.89
14	\$ 82,512.89	7%	\$ 5,775.90	\$ 9,534.63	\$ 5,775.90	\$ 15,310.53	\$ 72,978.26
15	\$ 72,978.26	7%	\$ 5,108.48	\$ 10,202.05	\$ 5,108.48	\$ 15,310.53	\$ 62,776.21
16	\$ 62,776.21	7%	\$ 4,394.33	\$ 10,916.20	\$ 4,394.33	\$ 15,310.53	\$ 51,860.01
17	\$ 51,860.01	7%	\$ 3,630.20	\$ 11,680.33	\$ 3,630.20	\$ 15,310.53	\$ 40,179.68
18	\$ 40,179.68	7%	\$ 2,812.58	\$ 12,497.96	\$ 2,812.58	\$ 15,310.53	\$ 27,681.72
19	\$ 27,681.72	7%	\$ 1,937.72	\$ 13,372.81	\$ 1,937.72	\$ 15,310.53	\$ 14,308.91
20	\$ 14,308.91	7%	\$ 1,001.62	\$ 14,308.91	\$ 1,001.62	\$ 15,310.53	\$ 0.00
<b>Total</b>				<b>\$ 162,200.00</b>	<b>\$ 144,010.65</b>	<b>\$ 306,210.65</b>	

TABLE 2. GEOTHERMAL SPACE HEATING RESTORATION FOR ADJACENT OFFICE BUILDING: ANNUALIZED INVESTMENT COST

Time Period	Investment	Interest Rate	Interest Accrued	Contribution to Investment	Interest Cost	Total Annual Cost	Remaining Investment Cost
0	\$ 26,000.00	7%				\$ -	\$ 26,000.00
1	\$ 26,000.00	7%	\$ 1,820.00	\$ 634.22	\$ 1,820.00	\$ 2,454.22	\$ 25,365.78
2	\$ 25,365.78	7%	\$ 1,775.60	\$ 678.61	\$ 1,775.60	\$ 2,454.22	\$ 24,687.17
3	\$ 24,687.17	7%	\$ 1,728.10	\$ 726.11	\$ 1,728.10	\$ 2,454.22	\$ 23,961.06
4	\$ 23,961.06	7%	\$ 1,677.27	\$ 776.94	\$ 1,677.27	\$ 2,454.22	\$ 23,184.12
5	\$ 23,184.12	7%	\$ 1,622.89	\$ 831.33	\$ 1,622.89	\$ 2,454.22	\$ 22,352.79
6	\$ 22,352.79	7%	\$ 1,564.70	\$ 889.52	\$ 1,564.70	\$ 2,454.22	\$ 21,463.27
7	\$ 21,463.27	7%	\$ 1,502.43	\$ 951.79	\$ 1,502.43	\$ 2,454.22	\$ 20,511.48
8	\$ 20,511.48	7%	\$ 1,435.80	\$ 1,018.41	\$ 1,435.80	\$ 2,454.22	\$ 19,493.07
9	\$ 19,493.07	7%	\$ 1,364.51	\$ 1,089.70	\$ 1,364.51	\$ 2,454.22	\$ 18,403.37
10	\$ 18,403.37	7%	\$ 1,288.24	\$ 1,165.98	\$ 1,288.24	\$ 2,454.22	\$ 17,237.39
11	\$ 17,237.39	7%	\$ 1,206.62	\$ 1,247.60	\$ 1,206.62	\$ 2,454.22	\$ 15,989.79
12	\$ 15,989.79	7%	\$ 1,119.29	\$ 1,334.93	\$ 1,119.29	\$ 2,454.22	\$ 14,654.86
13	\$ 14,654.86	7%	\$ 1,025.84	\$ 1,428.38	\$ 1,025.84	\$ 2,454.22	\$ 13,226.48
14	\$ 13,226.48	7%	\$ 925.85	\$ 1,528.36	\$ 925.85	\$ 2,454.22	\$ 11,698.12
15	\$ 11,698.12	7%	\$ 818.87	\$ 1,635.35	\$ 818.87	\$ 2,454.22	\$ 10,062.77
16	\$ 10,062.77	7%	\$ 704.39	\$ 1,749.82	\$ 704.39	\$ 2,454.22	\$ 8,312.95
17	\$ 8,312.95	7%	\$ 581.91	\$ 1,872.31	\$ 581.91	\$ 2,454.22	\$ 6,440.64
18	\$ 6,440.64	7%	\$ 450.84	\$ 2,003.37	\$ 450.84	\$ 2,454.22	\$ 4,437.27
19	\$ 4,437.27	7%	\$ 310.61	\$ 2,143.61	\$ 310.61	\$ 2,454.22	\$ 2,293.66
20	\$ 2,293.66	7%	\$ 160.56	\$ 2,293.66	\$ 160.56	\$ 2,454.22	\$ (0.00)
<b>Total</b>				<b>\$ 26,000.00</b>	<b>\$ 23,084.32</b>	<b>\$ 49,084.32</b>	

TABLE 3. GEOTHERMAL HEATED POOL ENCLOSURE: ANNUALIZED INVESTMENT COST

Time Period	Investment	Interest Rate	Interest Accrued	Contribution to Investment	Interest Cost	Total Annual Cost	Remaining Investment Cost
0	\$ 187,400.00	7%				\$ -	\$ 187,400.00
1	\$ 187,400.00	7%	\$ 13,118.00	\$ 4,571.23	\$ 13,118.00	\$ 17,689.23	\$ 182,828.77
2	\$ 182,828.77	7%	\$ 12,798.01	\$ 4,891.22	\$ 12,798.01	\$ 17,689.23	\$ 177,937.55
3	\$ 177,937.55	7%	\$ 12,455.63	\$ 5,233.61	\$ 12,455.63	\$ 17,689.23	\$ 172,703.94
4	\$ 172,703.94	7%	\$ 12,089.28	\$ 5,599.96	\$ 12,089.28	\$ 17,689.23	\$ 167,103.98
5	\$ 167,103.98	7%	\$ 11,697.28	\$ 5,991.96	\$ 11,697.28	\$ 17,689.23	\$ 161,112.02
6	\$ 161,112.02	7%	\$ 11,277.84	\$ 6,411.39	\$ 11,277.84	\$ 17,689.23	\$ 154,700.63
7	\$ 154,700.63	7%	\$ 10,829.04	\$ 6,860.19	\$ 10,829.04	\$ 17,689.23	\$ 147,840.44
8	\$ 147,840.44	7%	\$ 10,348.83	\$ 7,340.40	\$ 10,348.83	\$ 17,689.23	\$ 140,500.04
9	\$ 140,500.04	7%	\$ 9,835.00	\$ 7,854.23	\$ 9,835.00	\$ 17,689.23	\$ 132,645.81
10	\$ 132,645.81	7%	\$ 9,285.21	\$ 8,404.03	\$ 9,285.21	\$ 17,689.23	\$ 124,241.78
11	\$ 124,241.78	7%	\$ 8,696.92	\$ 8,992.31	\$ 8,696.92	\$ 17,689.23	\$ 115,249.47
12	\$ 115,249.47	7%	\$ 8,067.46	\$ 9,621.77	\$ 8,067.46	\$ 17,689.23	\$ 105,627.70
13	\$ 105,627.70	7%	\$ 7,393.94	\$ 10,295.30	\$ 7,393.94	\$ 17,689.23	\$ 95,332.40
14	\$ 95,332.40	7%	\$ 6,673.27	\$ 11,015.97	\$ 6,673.27	\$ 17,689.23	\$ 84,316.44
15	\$ 84,316.44	7%	\$ 5,902.15	\$ 11,787.08	\$ 5,902.15	\$ 17,689.23	\$ 72,529.35
16	\$ 72,529.35	7%	\$ 5,077.05	\$ 12,612.18	\$ 5,077.05	\$ 17,689.23	\$ 59,917.17
17	\$ 59,917.17	7%	\$ 4,194.20	\$ 13,495.03	\$ 4,194.20	\$ 17,689.23	\$ 46,422.14
18	\$ 46,422.14	7%	\$ 3,249.55	\$ 14,439.68	\$ 3,249.55	\$ 17,689.23	\$ 31,982.46
19	\$ 31,982.46	7%	\$ 2,238.77	\$ 15,450.46	\$ 2,238.77	\$ 17,689.23	\$ 16,531.99
20	\$ 16,531.99	7%	\$ 1,157.24	\$ 16,531.99	\$ 1,157.24	\$ 17,689.23	\$ -
<b>Total</b>				<b>\$ 187,400.00</b>	<b>\$ 166,384.69</b>	<b>\$ 353,784.69</b>	

TABLE 4. PROPOSED POOL COMPLEX MODIFICATIONS: ANNUALIZED INVESTMENT COST

Time Period	Investment	Interest Rate	Interest Accrued	Contribution to Investment	Interest Cost	Total Annual Cost	Remaining Investment Cost
0	\$ 213,400.00	7%				\$ -	\$ 213,400.00
1	\$ 213,400.00	7%	\$ 14,938.00	\$ 5,205.45	\$ 14,938.00	\$ 20,143.45	\$ 208,194.55
2	\$ 208,194.55	7%	\$ 14,573.62	\$ 5,569.83	\$ 14,573.62	\$ 20,143.45	\$ 202,624.72
3	\$ 202,624.72	7%	\$ 14,183.73	\$ 5,959.72	\$ 14,183.73	\$ 20,143.45	\$ 196,665.00
4	\$ 196,665.00	7%	\$ 13,766.55	\$ 6,376.90	\$ 13,766.55	\$ 20,143.45	\$ 190,288.10
5	\$ 190,288.10	7%	\$ 13,320.17	\$ 6,823.28	\$ 13,320.17	\$ 20,143.45	\$ 183,464.81
6	\$ 183,464.81	7%	\$ 12,842.54	\$ 7,300.91	\$ 12,842.54	\$ 20,143.45	\$ 176,163.90
7	\$ 176,163.90	7%	\$ 12,331.47	\$ 7,811.98	\$ 12,331.47	\$ 20,143.45	\$ 168,351.92
8	\$ 168,351.92	7%	\$ 11,784.63	\$ 8,358.82	\$ 11,784.63	\$ 20,143.45	\$ 159,993.11
9	\$ 159,993.11	7%	\$ 11,199.52	\$ 8,943.93	\$ 11,199.52	\$ 20,143.45	\$ 151,049.17
10	\$ 151,049.17	7%	\$ 10,573.44	\$ 9,570.01	\$ 10,573.44	\$ 20,143.45	\$ 141,479.17
11	\$ 141,479.17	7%	\$ 9,903.54	\$ 10,239.91	\$ 9,903.54	\$ 20,143.45	\$ 131,239.26
12	\$ 131,239.26	7%	\$ 9,186.75	\$ 10,956.70	\$ 9,186.75	\$ 20,143.45	\$ 120,282.56
13	\$ 120,282.56	7%	\$ 8,419.78	\$ 11,723.67	\$ 8,419.78	\$ 20,143.45	\$ 108,558.88
14	\$ 108,558.88	7%	\$ 7,599.12	\$ 12,544.33	\$ 7,599.12	\$ 20,143.45	\$ 96,014.55
15	\$ 96,014.55	7%	\$ 6,721.02	\$ 13,422.43	\$ 6,721.02	\$ 20,143.45	\$ 82,592.12
16	\$ 82,592.12	7%	\$ 5,781.45	\$ 14,362.00	\$ 5,781.45	\$ 20,143.45	\$ 68,230.12
17	\$ 68,230.12	7%	\$ 4,776.11	\$ 15,367.34	\$ 4,776.11	\$ 20,143.45	\$ 52,862.78
18	\$ 52,862.78	7%	\$ 3,700.39	\$ 16,443.06	\$ 3,700.39	\$ 20,143.45	\$ 36,419.72
19	\$ 36,419.72	7%	\$ 2,549.38	\$ 17,594.07	\$ 2,549.38	\$ 20,143.45	\$ 18,825.65
20	\$ 18,825.65	7%	\$ 1,317.80	\$ 18,825.65	\$ 1,317.80	\$ 20,143.45	\$ (0.00)
<b>Total</b>				<b>\$ 213,400.00</b>	<b>\$ 189,469.01</b>	<b>\$ 402,869.01</b>	

**TABLE 5. COMMUNITY CENTER GEOTHERMAL RETROFIT OPTIONS 1 & 2: ANNUALIZED INVESTMENT COST**

Time Period	Investment	Interest Rate	Interest Accrued	Contribution to Investment	Interest Cost	Total Annual Cost	Investment Remaining
0	\$ 20,000.00	7%				\$ -	\$ 20,000.00
1	\$ 20,000.00	7%	\$ 1,400.00	\$ 487.86	\$ 1,400.00	\$ 1,887.86	\$ 19,512.14
2	\$ 19,512.14	7%	\$ 1,365.85	\$ 522.01	\$ 1,365.85	\$ 1,887.86	\$ 18,990.13
3	\$ 18,990.13	7%	\$ 1,329.31	\$ 558.55	\$ 1,329.31	\$ 1,887.86	\$ 18,431.58
4	\$ 18,431.58	7%	\$ 1,290.21	\$ 597.65	\$ 1,290.21	\$ 1,887.86	\$ 17,833.94
5	\$ 17,833.94	7%	\$ 1,248.38	\$ 639.48	\$ 1,248.38	\$ 1,887.86	\$ 17,194.45
6	\$ 17,194.45	7%	\$ 1,203.61	\$ 684.25	\$ 1,203.61	\$ 1,887.86	\$ 16,510.21
7	\$ 16,510.21	7%	\$ 1,155.71	\$ 732.14	\$ 1,155.71	\$ 1,887.86	\$ 15,778.06
8	\$ 15,778.06	7%	\$ 1,104.46	\$ 783.39	\$ 1,104.46	\$ 1,887.86	\$ 14,994.67
9	\$ 14,994.67	7%	\$ 1,049.63	\$ 838.23	\$ 1,049.63	\$ 1,887.86	\$ 14,156.44
10	\$ 14,156.44	7%	\$ 990.95	\$ 896.91	\$ 990.95	\$ 1,887.86	\$ 13,259.53
11	\$ 13,259.53	7%	\$ 928.17	\$ 959.69	\$ 928.17	\$ 1,887.86	\$ 12,299.84
12	\$ 12,299.84	7%	\$ 860.99	\$ 1,026.87	\$ 860.99	\$ 1,887.86	\$ 11,272.97
13	\$ 11,272.97	7%	\$ 789.11	\$ 1,098.75	\$ 789.11	\$ 1,887.86	\$ 10,174.22
14	\$ 10,174.22	7%	\$ 712.20	\$ 1,175.66	\$ 712.20	\$ 1,887.86	\$ 8,998.55
15	\$ 8,998.55	7%	\$ 629.90	\$ 1,257.96	\$ 629.90	\$ 1,887.86	\$ 7,740.59
16	\$ 7,740.59	7%	\$ 541.84	\$ 1,346.02	\$ 541.84	\$ 1,887.86	\$ 6,394.58
17	\$ 6,394.58	7%	\$ 447.62	\$ 1,440.24	\$ 447.62	\$ 1,887.86	\$ 4,954.34
18	\$ 4,954.34	7%	\$ 346.80	\$ 1,541.05	\$ 346.80	\$ 1,887.86	\$ 3,413.28
19	\$ 3,413.28	7%	\$ 238.93	\$ 1,648.93	\$ 238.93	\$ 1,887.86	\$ 1,764.35
20	\$ 1,764.35	7%	\$ 123.50	\$ 1,764.35	\$ 123.50	\$ 1,887.86	\$ (0.00)
<b>Total</b>				\$ 20,000.00	\$ 17,757.17	\$ 37,757.17	

**TABLE 6. COMMUNITY CENTER GEOTHERMAL RETROFIT OPTION 3: ANNUALIZED INVESTMENT COST**

Time Period	Investment	Interest Rate	Interest Accrued	Contribution to Investment	Interest Cost	Total Annual Cost	Investment Remaining
0	\$ 30,000.00	7%				\$ -	\$ 30,000.00
1	\$ 30,000.00	7%	\$ 2,100.00	\$ 731.79	\$ 2,100.00	\$ 2,831.79	\$ 29,268.21
2	\$ 29,268.21	7%	\$ 2,048.77	\$ 783.01	\$ 2,048.77	\$ 2,831.79	\$ 28,485.20
3	\$ 28,485.20	7%	\$ 1,993.96	\$ 837.82	\$ 1,993.96	\$ 2,831.79	\$ 27,647.38
4	\$ 27,647.38	7%	\$ 1,935.32	\$ 896.47	\$ 1,935.32	\$ 2,831.79	\$ 26,750.90
5	\$ 26,750.90	7%	\$ 1,872.56	\$ 959.22	\$ 1,872.56	\$ 2,831.79	\$ 25,791.68
6	\$ 25,791.68	7%	\$ 1,805.42	\$ 1,026.37	\$ 1,805.42	\$ 2,831.79	\$ 24,765.31
7	\$ 24,765.31	7%	\$ 1,733.57	\$ 1,098.22	\$ 1,733.57	\$ 2,831.79	\$ 23,667.09
8	\$ 23,667.09	7%	\$ 1,656.70	\$ 1,175.09	\$ 1,656.70	\$ 2,831.79	\$ 22,492.00
9	\$ 22,492.00	7%	\$ 1,574.44	\$ 1,257.35	\$ 1,574.44	\$ 2,831.79	\$ 21,234.65
10	\$ 21,234.65	7%	\$ 1,486.43	\$ 1,345.36	\$ 1,486.43	\$ 2,831.79	\$ 19,889.29
11	\$ 19,889.29	7%	\$ 1,392.25	\$ 1,439.54	\$ 1,392.25	\$ 2,831.79	\$ 18,449.76
12	\$ 18,449.76	7%	\$ 1,291.48	\$ 1,540.30	\$ 1,291.48	\$ 2,831.79	\$ 16,909.45
13	\$ 16,909.45	7%	\$ 1,183.66	\$ 1,648.13	\$ 1,183.66	\$ 2,831.79	\$ 15,261.32
14	\$ 15,261.32	7%	\$ 1,068.29	\$ 1,763.50	\$ 1,068.29	\$ 2,831.79	\$ 13,497.83
15	\$ 13,497.83	7%	\$ 944.85	\$ 1,886.94	\$ 944.85	\$ 2,831.79	\$ 11,610.89
16	\$ 11,610.89	7%	\$ 812.76	\$ 2,019.03	\$ 812.76	\$ 2,831.79	\$ 9,591.86
17	\$ 9,591.86	7%	\$ 671.43	\$ 2,160.36	\$ 671.43	\$ 2,831.79	\$ 7,431.51
18	\$ 7,431.51	7%	\$ 520.21	\$ 2,311.58	\$ 520.21	\$ 2,831.79	\$ 5,119.92
19	\$ 5,119.92	7%	\$ 358.39	\$ 2,473.39	\$ 358.39	\$ 2,831.79	\$ 2,646.53
20	\$ 2,646.53	7%	\$ 185.26	\$ 2,646.53	\$ 185.26	\$ 2,831.79	\$ -
<b>Total</b>				\$ 30,000.00	\$ 26,635.76	\$ 56,635.76	

## FIGURE 1. GEOTHERMAL HEATING CONSIDERATIONS FOR PROPOSED LAVA HOT SPRINGS POOL ENCLOSURE

ADDITIONAL CAPITAL COSTS ASSOCIATED WITH GEOTHERMAL HEATING PROPOSED POOL ENCLOSURE: \$ 19,440.00

### FINANCIAL FACTORS

Interest Rate	7%
Investment Life	20
Annuity Factor	0.094392926

### ESTIMATED COMMUNITY CENTER ENERGY USE FOR SPACE HEATING AND ENERGY USE FACTORS

Month	Therm	Energy Use Factor	
		December = 100	
May-02	171	0.47	
Jun-02	0	0.00	
Jul-02	0	0.00	
Aug-02	0	0.00	
Sep-02	57	0.16	
Oct-02	146	0.40	
Nov-02	312	0.85	
Dec-02	366	1.00	
Jan-03	292	0.80	
Feb-03	339	0.93	
Mar-03	246	0.67	
Apr-03	132	0.36	

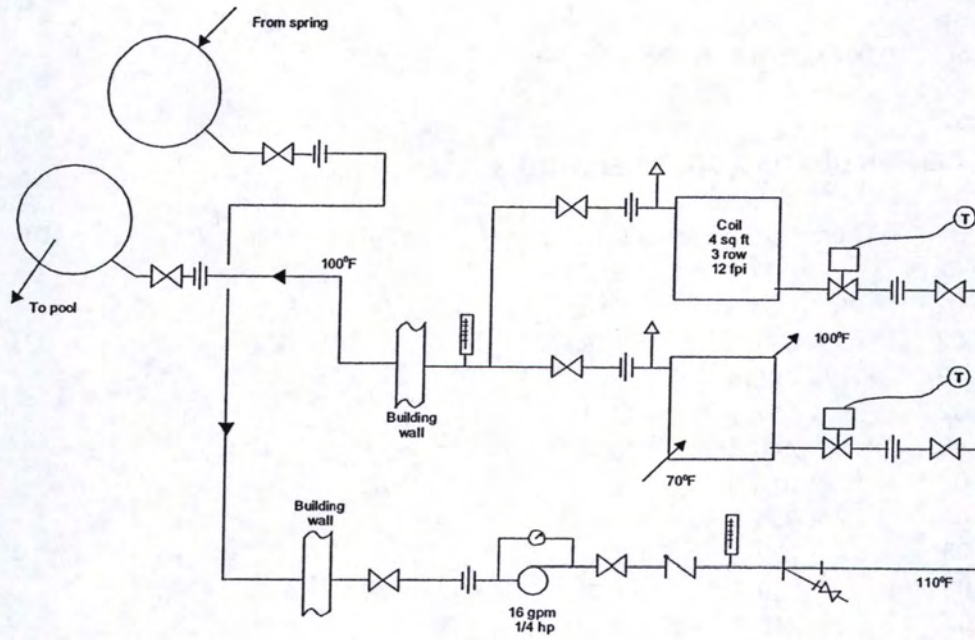
### ESTIMATED POOL ENCLOSURE NATURAL GAS HEATING COSTS

Month	Days	Energy Use Factor		Monthly Energy Requirement (1000 cu ft) <sup>1</sup>	\$/1000 cu ft <sup>2</sup>	Monthly Heating Costs
		December = 100				
May	31	0.47		147.77	6.76 \$	998.96
June	30	0.00		-	7.11 \$	-
July	31	0.00		-	7.58 \$	-
August	31	0.00		-	7.94 \$	-
September	30	0.16		47.67	8.63 \$	411.39
October	31	0.40		126.17	9.56 \$	1,206.19
November	30	0.85		260.93	9.74 \$	2,541.42
December	31	1.00		316.29	9.34 \$	2,954.15
January	31	0.80		252.34	9.16 \$	2,311.44
February	28	0.93		264.61	8.96 \$	2,370.87
March	31	0.67		212.59	8.79 \$	1,868.65
April	30	0.36		110.39	8.88 \$	980.28
<b>Annual Heating Cost</b>						<b>\$ 15,643.35</b>

<sup>1</sup> Assuming 1035 BTU per Cubic Foot of Natural Gas: Source: Energy Information Administration Annual Energy Review 2001

<sup>2</sup> Source: Energy Information Administration. [http://www.eia.doe.gov/emeu/states/\\_states.html](http://www.eia.doe.gov/emeu/states/_states.html) 2002 Time Series Prices

**FIGURE 2. COMMUNITY CENTER: GEOTHERMAL RETROFIT INSTALLATION LAYOUT FOR ALL OPTIONS**



### FIGURE 3. GEOTHERMAL RETROFIT CONSIDERATIONS FOR LAVA HOT SPRINGS COMMUNITY CENTER

#### FINANCIAL FACTORS

	Options 1 & 2	Option3
Investment Cost \$	20,000 \$	30,000
Interest Rate	7%	7%
Investment Life	20	20
Annuity Factor	0.094392926	0.094392926

#### COMMUNITY CENTER HEATING CONSIDERATIONS

Month	Therm	Heating Cost
May-02	111 \$	97.86
Jun-02	56 \$	50.40
Jul-02	47 \$	31.88
Aug-02	46 \$	30.53
Sep-02	57 \$	37.34
Oct-02	146 \$	92.41
Nov-02	312 \$	192.64
Dec-02	366 \$	213.50
Jan-03	292 \$	173.19
Feb-03	339 \$	198.79
Mar-03	246 \$	148.13
Apr-03	132 \$	83.75
<b>Annual Heating Cost</b>	<b>\$</b>	<b>1,350.42</b>

		Fuel Cost Savings	Remaing Fuel Cost
<b>Option 1:</b>	Offset 50% of gas heating requirments	\$ 675.21	\$ 675.21
<b>Option 2:</b>	Offset 80% of gas heating requirements	\$ 1,080.34	\$ 270.08
<b>Option 3:</b>	Offset 100% of gas heating requirments	\$ 1,350.42	\$ -