

File A-054 =

Intensive Aquaculture Methods Research:

A Progress Report

By

George W. Klontz,
Professor, Fishery Resources

Irvin R. Brock
Graduate Assistant

and

John A. McNair
Graduate Assistant

College of Forestry, Wildlife and Range Sciences
University of Idaho
Moscow, Idaho

Preface

This report represents a Technical Completion Report of a 15 month study entitled, "Aquaculture Techniques: Water Use and Discharge Quality". The supporting agency was the Office of Water Research and Technology, Department of the Interior. The project was administered through the Idaho Water Resources Research Institute, University of Idaho.

In writing this report, we have attempted to present our findings and conclusions from a practical standpoint. It is our hope that fish culturists in both the public and private sectors of aquaculture will find some of the concepts and methods contained herein useful.

The collaborative efforts of the Idaho Department of Fish and Game are gratefully appreciated - especially the personnel at the Rapid River Salmon Hatchery and the Hagerman Trout Hatchery.

TABLE OF CONTENTS

		Page
Section:	I Introduction	1
	II Factors Affecting the Production of an Aquaculture Facility: A Commentary.	5
	III Factors in Waste Product Generation: A Review	10
	IV Growth and Growth Programming: A Review	16
	V Description of General Approach to the Study	28
	VI The Effect of Density and Growth Rate on the Weight-Dependent Oxygen Consumption: A Study	36
	VII Evaluation of Growth Data: A Method	50
	VIII Effects of Population Density and Water Replacement Time on Growth: A Study	59
	IX Estimation of Solids Generated in an Aquaculture System: A Study	70
	X Summary.	82
Appendix:	I Published Carrying Capacity Methods.	84
	II List of OWRT Fish Culture Program.	90
	III List of BROCK Fish Culture Program.	93
	IV List of IRV Fish Culture Program	99
	V Computer Output Exhibit Using the OWRT Program	106
	VI Computer Output Exhibits Using the IRV Program	108

I. INTRODUCTION

Abatement or, at least, reduction of pollutants in ground waters and streams is currently a national priority. In this regard, the Environmental Protection Agency in 1974 issued a "Development Document for Proposed Effluent Limitations Guidelines and Performance Standards for Fish Hatcheries and Farms". The final regulations have not been promulgated but the issuance of permits, based upon the proposed guidelines, has been in progress for the past year or two.

Although the initial discharge limits in effect until June 30, 1977 for ammonia-nitrogen and solids (both suspended and settleable) were not too restrictive, the limits proposed for the period beginning 1 July 1977 are quite restrictive and will require extensive modification of current fish culture practices at most fish hatcheries and farms in Idaho and elsewhere in the nation. The proposed limits were derived largely from data gathered empirically and, in the opinions of many, are rather unrealistic. Furthermore, current fish culture methodology is not adequate to predict the time at which the limits will be exceeded in a given fish culture situation. In other words, an individual will not know he has exceeded the permitted discharge limitations until he has done so.

Idaho currently ranks third behind Washington and Oregon, in that order, in numbers of existing hatchery facilities. However, in terms of pounds of fish produced, Idaho leads the nation in trout and salmon production. The commercial food fish industry in Idaho produces 15-20 million pounds of rainbow trout and channel catfish annually in 69 currently licensed facilities. This is approximately 90% of the nation's commercial processed trout production. The Idaho Department of Fish and Game currently operates 17 hatcheries throughout the state. In FY-1974 the Department released 9.3 million spring chinook salmon, 0.3 million summer chinook salmon, 6.7 million steelhead, and 5.2

million rainbow trout. During the same period the three U.S. Fish and Wildlife Service hatcheries in Idaho released 1.8 million steelhead, 3.0 million kokanee, 1.5 million rainbow trout, and 0.8 million spring and summer chinook salmon.

The majority of the commercial fish farms (46 out of 69), one National Fish Hatchery, and three Idaho Department of Fish and Game hatcheries lie along a 25-mile stretch of the Snake River extending from Twin Falls downstream to Hagerman (Figure 1). The current standing crop; i.e., pounds of fish on hand each day, in these hatcheries is estimated at 6-7 million pounds. At a dietary efficiency of 65% and at an average feeding level of 3% of body weight (based upon current practices), these facilities discharge an estimated 63,000-73,000 pounds of biological contaminants daily into the Snake River (Klontz and King, 1975).

Based upon the foregoing, at least two problems regarding fish hatchery and farm effluents become apparent: 1) How to reduce economically the waste load in effluents from fish culture operations; 2) How to raise fish within the permitted discharge limitations.

This project was designed to define the problems, to test methods for their resolution, and to implement those methods deemed most appropriate for the particular situation. It had the following objectives:

- 1) To determine the rate (lbs/100 kilocalories metabolizable energy/lb of feed) of production of the following by rainbow trout.
 - a) carbon dioxide
 - b) ammonia nitrogen
 - c) phosphate phosphorous
 - d) solids (suspended and settleable)
 - e) dissolved oxygen depletion

- 2) To determine the optimum pounds of rainbow trout per inch of body length per cubic foot of water per water change per hour.
- 3) To construct and to test a rainbow trout production program designed to predict the time at which the following will exceed levels established for the particular situation:
 - a) lbs fish/in. body length/cu.ft. of water/water change/hr.
 - b) carbon dioxide
 - c) ammonia nitrogen
 - d) phosphate phosphorous
 - e) settleable solids
 - f) suspended solids
 - g) dissolved oxygen depletion

This project derived its data inputs from a highly controlled laboratory study and from field studies at the Hagerman State Hatchery, Idaho Department of Fish and Game.

References Cited

- Klontz, G.W. and J.G. King (1975): Aquaculture in Idaho and Nationwide. Res. Tech. Compl. Report IDWR Proj. 45-080.

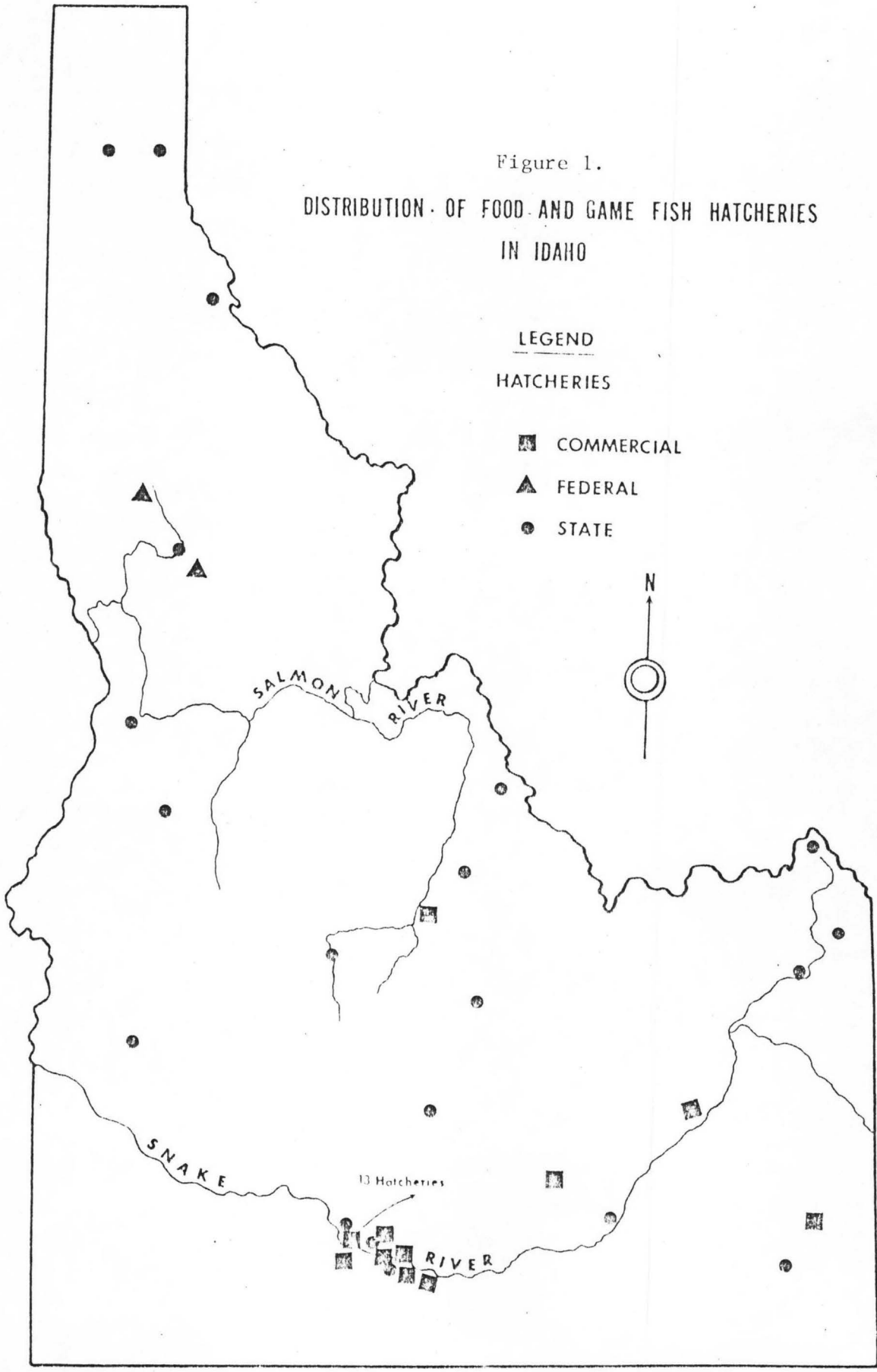

Figure 1.
DISTRIBUTION OF FOOD AND GAME FISH HATCHERIES
IN IDAHO

LEGEND
HATCHERIES

- COMMERCIAL
- ▲ FEDERAL
- STATE



II. FACTORS AFFECTING THE PRODUCTIVITY OF AN AQUACULTURE FACILITY: A COMMENTARY

In any aquaculture facility the following are identifiable as major components: fish; water; container; nutrition; management. Each has one or more interactions with each other and each consists of several unique factors which may or may not be present individually at any one particular facility (Table 1). Nonetheless, when each is present it can have some positive or negative influence on the productivity of the facility.

The factors associated with each major component can, in most cases, be quantitated. Also, each factor must be considered as having either a cause or an effect role with one or more factors. For example, if the water depth in a pond of fish were decreased by 30% with nothing else changed, the following direct effects on the fish would occur: 1) increased swimming activity; 2) increased density; i.e., pounds of fish per cubic foot of water. As a result of the increased swimming activity the following would occur: 1) increased oxygen demand; 2) increased nutritional demand; 3) decreased growth rate. The point being made is that altering one of the many variable factors in an aquaculture facility has either direct or indirect effects on one or more other components. To accurately assess the effects, the direct effects must be considered separately from the indirect. For example, in the original illustration, the water depth was decreased by 30% and one of the indirect effects of this on the fish was to decrease the growth rate. This effect could be offset quantitatively by increasing the feeding rate. However, what will be the effects on the fish by increasing the feeding rate? First, there will be an increased oxygen demand - in addition to the oxygen demand created by the increased swimming activity. Second, there will be an expected change in growth rate. Indirectly, on the environment; i.e., the water, there will be the following effects: 1) increased ammonia-nitrogen production; 2)

increased solids production; 3) decreased carrying capacity. It then follows, then to consider what effects these environmental changes have on the fish. As can be seen, it is no easy matter to manage environmental causes and effects in an aquaculture system.

When considering several of the direct and indirect cause and effect interrelationships of the variables found in an aquaculture system (Table 1), it is our recommendation that a chart (Figure 2) be constructed listing the individual variables changed along one axis and the variables affected directly and inversely along the other axis. By ascribing the letter D for direct cause and effect and the letter I for inverse cause and effect, one can visualize the far-reaching effects of altering a variable and what variables can be altered.

Table 1. Interdependent and independent variables affecting fish production.

I. Fish Associated

- A. Ammonia-nitrogen
- B. Behavior
- C. Nutritional requirements
- D. Environmental requirements
 - 1. Physical
 - 2. Chemical
- E. Growth rate
- F. Infectious disease
- G. Length-weight relationship
- H. Product definition
- I. Cannibalism
- J. Oxygen uptake

II. Water Associated

- A. Dissolved oxygen
- B. Nitrite-nitrogen
- C. Alkalinity/hardness
- D. pH
- E. Inflow in gpm or cfs
- F. Suspended solids
- G. Settleable solids
- H. Temperature (constant or variable)
- I. Carrying capacity
- J. Agricultural contaminants
- K. Industrial contaminants

Table 1. Continued.

- L. Municipal contaminants
 - M. Natural contaminants
 - N. Utilization
 - O. Salinity
- III. Container Associated
- A. Water volume
 - B. Water velocity
 - C. Composition
 - D. Water flow pattern
 - E. Outfall design
- IV. Nutrition Associated
- A. Feeding rate
 - B. Feed efficiency
 - C. Feed style
 - D. Nutritional quality
 - 1. Proximate analysis
 - 2. Metabolizable energy
 - E. Feed storage
- V. Management Associated
- A. Fish sampling techniques
 - B. Feeding frequency
 - C. Feeding techniques
 - D. Record keeping
 - E. Pond cleaning
 - F. Fish size grading techniques
 - G. Management programming
 - H. Management objectives

Figure 2. Chart of the direct (D) and indirect (I) effects of changing variables in an aquaculture system.

Factors Affected

Factor changed:	ΔL	Water velocity (R_V)	Feed demand (FD)	$R\Delta$	DO	Solids	OD	NH_3-N	DF	Conversion
Volume	I	D	I	D	I		I		D	I
Water inflow	I	D	D	D	D/I		D			
Growth rate (ΔL)			D				D			
Feeding rate	D					D	D	D		D/I
Water replacement (R_Δ)	I	D	I		D					
Dissolved oxygen (DO)	D		D							
Temperature	D/I		D				D			
Density factor (DF)	D				I		I			
Feed	D		D			D		D		D/I

III. FACTORS IN WASTE PRODUCT GENERATION:

A REVIEW

Fish are nonconsumptive users of water; however, they do alter biologically the water in which they reside. The more important biological alterations include: 1) increased nitrogenous compounds; i.e., ammonia-nitrogen, nitrite-nitrogen, and nitrate-nitrogen; 2) increased carbon dioxide and phosphates; 3) increased solids - both suspended and settleable; 4) decreased dissolved oxygen; 5) increased biological oxygen demand (BOD).

The generation of waste products in an aquaculture facility consists of a rather complex series of interactions among fish, nutrition, water, and management. The container component does interact to some degree but is largely dependent upon the interactions of the other components. Simplistically, the fish-nutrition interactions would seem to be the most important but they are modified drastically by the interactions with and among the other two components.

The readily identifiable fish-associated factors involved in the quality and quantity of waste product generation are:

- 1) Size: Currently, fish being raised in Idaho range in size from 1" to over 12". The smaller fish eat more; i.e., a higher percentage of body weight, than do larger fish; but there are generally less pounds of small fish on hand at any one time. Also, the presence of small fish in a fish culture facility, especially one producing a game fish, is seasonal with the highest poundage occurring in the fall and winter.
- 2) Species: In Idaho, the following fishes are being reared in hatcheries and farms: rainbow, steelhead, brook, brown, cutthroat, kokanee, Dolly Varden, coho, spring chinook, summer chinook, grayling, channel catfish, blue catfish, Tilapia, mackinaw, and Kamloop. It

has been convenient to assume that all species of salmonids are similar. In many respects they are but each has its own unique behavior, space requirements, nutritional requirements, temperature preferences, growth rates, and metabolic pathways.

3) Growth rates: Growth rates of fish are intimately dependent upon water temperature and caloric intake. Under optimal conditions for the species being raised, the growth rate of salmonids can approach 1.5 inches per month. At this level the caloric intake is approximately twice that required for what would be construed as a "normal" growth rate. Conservation hatcheries; i.e., state and federal, as a general rule grow fish at a lower rate than do commercial hatcheries. Therefore, the waste load generated in pounds per 100 pounds of fish daily from a commercial facility could be greater than that generated from a conservation facility.

The readily identifiable nutrition-associated factors involved in the quality and quantity of waste product generation are:

1) Metabolizable energy: It is generally accepted that salmonids require 1650 kcal per pound of weight gain and that catfish require 1750 kcal per pound of weight gain. Commercially available feeds contain 1100-1200 kcal metabolizable energy per pound. Theoretically, then, a feed conversion, i.e., pounds of feed required per pound of gain in fish, of 1.5-1.375, respectively, could be expected for salmonids and 1.59-1.46, respectively, for catfish. This suggests that for each pound of feed fed to salmonids there is 0.33-0.27 pound, respectively, of waste generated. For catfish there would be 0.37-0.32 pound, respectively, of waste generated per pound of feed fed.

2) Feed conversion (or dietary efficiency): As has been stated, under ideal conditions 1.375-1.5 pounds of feed will produce a pound of weight

gain in salmonids. However, in practice this does not always occur. The "real life" feed conversion range from 1.3-1.5 for small fish (1"-3"), 1.5-1.7 for medium sized fish (3"-8"), and 1.8-2.0 for large fish (8"-12"). This makes estimating the waste load in discharge waters difficult.

3) Quantity: The quantity of feed fed daily is directly dependent upon the desired growth rate, fish size, and dietary efficiency. This can be expressed as the pounds of feed per 100 pounds of fish being calculated from dividing the Pond Constant by the length (in inches) of the fish being fed. The Pond Constant is derived by multiplying the ΔL (daily length increase in inches) by the estimated or historical feed conversion and then multiplying the result by 300. The 300 is derived from a length-weight conversion factor of 3 and a decimal-removing factor of 100. An example of feeding different lengths of fish at frequently used Pond Constants is presented in Table Z.

The readily identifiable water-associated factors involved in the quality and quantity of waste product generation are:

1) Temperature: Salmonids growing at their preferred water temperature - termed the Standard Environmental Temperature (SET) - can increase their length by nearly 1.5 inches per month. For each $^{\circ} F$ decrease from their SET, salmonids decrease their metabolic rate by approximately 5% and, correspondingly, their metabolic intake and waste product output. The fish-raising facilities in the Hagerman Valley are supplied with year-around $59^{\circ} F$ water. Facilities in other parts of the state have seasonal water temperature fluctuations ranging from the low-40's to the low-60's.

Table 2. Pounds of feed^a and pounds waste generated per 100 pounds of fish at length (L) at different Pond Constants (PC)^b.

L	PC = 12.5		PC = 15		PC = 17.5		PC = 20	
	lbs feed	lbs waste	lbs feed	waste	lbs feed	lbs waste	lbs feed	lbs waste
1	12.5	4.1	15.0	5.0	17.5	5.8	20.0	6.6
2	6.3	2.1	7.5	2.5	8.8	2.9	10.0	3.3
3	4.2	1.4	5.0	1.7	5.8	1.9	6.7	2.2
4	3.1	1.0	3.8	1.3	4.4	1.5	5.0	1.7
5	2.5	0.8	3.0	1.0	3.5	1.2	4.0	1.3
6	2.1	0.7	2.5	0.8	2.9	1.0	3.3	1.1
7	1.8	0.6	2.1	0.7	2.5	0.8	2.9	1.0
8	1.6	0.5	1.9	0.6	2.2	0.7	2.5	0.8
9	1.4	0.5	1.7	0.6	1.9	0.6	2.2	0.7
10	1.3	0.4	1.5	0.5	1.8	0.6	2.0	0.6

^a Using the Buterbaugh-Willoughby modification of Haskell's method.

^b Using the Willoughby et al. (1972) method.

^c PC	L	Conv.
12.5	0.078	1.5
15	0.033	1.5
17.5	0.038	1.5
20	0.044	1.5

2) Dissolved oxygen: Most fish - salmonids, in particular - require a minimum of 5 mg/l dissolved oxygen. At this level growth is marginal. For optimum growth, fish-raising waters should be 95% saturated with oxygen, with both temperature and altitude affecting the oxygen-carrying capacity. Spring waters in the Hagerman Valley have dissolved oxygen levels of 9.0-9.3 mg/l.

As was noted earlier, small fish have a higher metabolic rate than do large fish. Correspondingly, the oxygen demand in small fish decreases with age. Carrying capacities of fish raceways and ponds, in pounds per cubic foot of rearing space or per gallon per minute of water in-flow, are calculated by taking into account the amount of available dissolved oxygen and the oxygen demand for the particular sized fish.

The readily identifiable management-associated factors involved in the quality and quantity of waste product generation are:

- 1) Feeding techniques: In Idaho, fish are fed by hand, by truck-mounted blowers, by track-mounted blowers, by stationary, mechanical feeders, and by demand feeders. Each style has its unique favorable and unfavorable qualities. As a general rule, hand feeding is the least wasteful and the most accurate but the most costly from a labor standpoint. Uneaten feed contributes significantly to the solids load in the discharge and to the increasing cost of raising fish.
- 2) Feeding frequency: Fish fed several times each day generally perform better than do fish fed only once or twice a day. Also, there is less likelihood of wasting feed with increased feeding frequency.
- 3) Growth programming: This is a relatively new fish culture practice which is receiving increasing interest and application. It has its basis in taking into account all the interactions of fish, water,

container, nutrition, and management so that a desired product may be obtained within the scheduled time. It also has the benefits of reducing production costs, increasing production efficiency, and reducing loss-of-production potential.

4) Pond cleaning, inventorying, harvesting, and grading: These acts on any fish-raising facility are often referred to collectively as "working the fish". On any occasion when fish are handled, sediments (uneaten feed, fish feces, algae, etc.) are disturbed and swept out in the discharge. More frequent cleaning of ponds decreases the sedimented load which decreases the BOD and which, in turn, increases the fish carrying capacity of the pond or stream below the discharge. It should also be pointed out that any working of the fish creates a potential health hazard for the fish. The inherent stress may by itself be lethal or it may induce a latent microbial infection into becoming a clinical outbreak resulting in a significant economic loss.

IV. GROWTH AND GROWTH PROGRAMMING: A REVIEW

Growth of fish in an aquaculture system can be quantitated by documenting changes in length, weight, or number of fish per pound. All three are currently used by fish culturists.

Growth programming is the practice of predicting the rate of growth during a period of time termed either the growth period or inventory period. It has as its basis the over-all gain in either pounds or inches divided by the number of growth or inventory periods available. On most facilities the growth period is 14-15 days while on some it may be 30 days. For example, in a conservation hatchery raising fall-spawning rainbow trout for mid-summer release into the wild as 7-inch fish, will have approximately 8-9 months production time. Assuming that the facility has 15C water, the growth rate can exceed 0.5 in. per 14 day period. Assuming further that the fish can be ready for programmed growth (i.e., 1.35 in. or 1000/lb) 1-2 months after the eggs are taken, it will leave 6-8 months actual growth time. This means that the fish will have to grow 5.65 in. in 7 months (av.) or 0.4 in. per 14-day period. The problem now is how to do it with the reasonable assurance meeting the deadline.

Before dealing with the above problem specifically, there is another problem which must be considered; namely, pond loading or carrying capacity. Every fish raising facility consists of some sort of ponds into and out of which water flows to keep the fish hale and hearty. The interrelationships of pond and water flow are integral components of growth programming. The fish depend upon them for life support (DO), removing the accumulated excretory products ($\text{NH}_3\text{-N}$ and solids), and for providing the environment in which the innate behavior pattern requirements of the fish are met.

To date there have been seven published methods to determine the carrying capacity of a pond (Haskell 1955; Willoughby 1968; Elliott 1969; Westers 1970; Piper 1970; Liao 1971; Piper 1972). Each of the seven takes into account two or more of the following variables occurring in the system (Appendix I):

Fish associated - growth rate

weight

length

oxygen uptake

Pond associated - volume

Density Index

Water associated - inflow

changes per hour

temperature

dissolved oxygen

elevation

lbs fish/gpm

lbs fish/cu. ft.

lbs fish per pond

Feed associated - feeding rate

Carrying capacity values obtained from applying each method to a fish raising system appear quite realistic when viewed individually; however, a wide disparity among values is seen when the individual values are viewed collectively (Table 3). The primary reason for this lies in the factors taken into account by the individual methods (Table 4).

Haskell's Feeding Level Method estimates the carrying capacity from knowing historically how many pounds of feed can be fed per cubic foot of water, the limits of which are based upon the available dissolved oxygen. Then, by

Table 3. Comparison of reported pond loading calculations.

Pond:	1920 cu.ft. (8' x 80' x 3')
Fish:	6" rainbow trout (0.086 lb each) ($K=4.05 \times 10^{-4}$)
Water temp.:	58 ^o F
Dissolved oxygen:	9.8 mg/l
Elevation:	1000' above MSL
Water flow:	1.07 cfs (481.5 gpm)
Water changes/hr:	2.0
Max. feed/cu.ft.	0.05
Feeding rate (R_f)	2.4%

<u>METHOD</u>	<u>LBS FISH IN POND</u>
Haskell	4000
Willoughby	5725
Westers	5376
Piper (Load Factor)	3813
Liao	3263
Piper (Density factor = 0.5)	5760
<hr/>	
Mean	4656
Range	3263-5760

Table 4. Factors considered by the published methods of calculating carrying capacity.

FACTOR	METHODS						
	Haskell	Willoughby	Westers	Elliott	Piper (1970)	Liao	Piper (1972)
Pond volume	XX		XX				XX
Water inflow		XX	XX		XX	XX	
Water changes per hour			XX				
Water temperature				XX	XX	XX	
Dissolved oxygen		XX		XX	XX	XX	
Elevation					XX	XX	
Fish length					XX		XX
Fish weight						XX	
Density Index							XX
Lbs fish/gpm			XX	XX	XX	XX	
Lbs fish/cu.ft.	XX		XX				
Oxygen uptake		XX		XX		XX	
Lbs fish/pond		XX	XX		XX	XX	XX
Growth rate	XX						
Feeding rate	XX	XX					

dividing the estimated feeding rate into the pounds of feed permitted and multiplying the result by the cubic feet available, the maximum number of pounds of fish and the pond will support is estimated (Haskell 1955).

Willoughby's Feeding Level Method is similar to Haskell's in that it is based upon the pounds of feed that can be metabolized by fish in the pond. The amount of feed is estimated from the available dissolved oxygen rather than historical data as was the case in Haskell's method. The available dissolved oxygen is calculated from the difference between inflow and outfall oxygen levels. The feeding rate is determined from ΔL method (Haskell 1959).

Westers' Water Replacement Time Method estimates pond loading based upon pounds of fish per gpm (W_{gpm}) times the water changes per hour (R_{Δ}) times the volume (V) all divided by 8 (a factor converting gpm to cfh). W_{gpm} was obtained from a series of temperature-correlated graphs considering pounds of fish per ft^3 , fish length, and water changes per hour.

Elliott's Oxygen Uptake Method estimates the pounds of fish per gpm from dividing the oxygen demand for a fish of specified weight into the available dissolved oxygen. The method was derived for chinook salmon fingerlings.

Piper's Load Factor Method estimates the pond loading based upon the pounds of fish per gpm per inch of fish (F) times the gpm (I) times the length of the fish (L). F was derived empirically and corrected for water temperature and evaluation to correspond to the amount of available dissolved oxygen.

Liao's Oxygen Consumption Method estimates pond loading based upon the oxygen consumption of a fish of specified weight, the amount of dissolved oxygen available, and the water inflow. When comparing the pond loading for rainbow trout using this method with that obtained using Piper's Load Factor Method, Liao's estimate is 16.3% less than Piper's irregardless of the pond volume or water inflow. However, when the same pond data are used with chinook salmon the differences are very irregular.

Piper's Density Index Method estimates pond loading based upon the space factor requirement for the species of fish in question. For example, rainbow trout grow well at a density of 0.5 lbs of fish per cubic foot of water per in. of body length. Cutthroat perform well at a density of 0.3 pounds per cubic foot per inch of body length. This Density Factor takes into account only the psychological requirements of the fish in question; i.e., some fish can stand crowded conditions and some cannot. In this method there is no consideration of life support parameters. To apply this method, the life support capabilities of the pond must be balanced with the space capabilities of the pond.

One definition of carrying capacity is the maximum quantity of fish able to remain healthy in a system. Implicit in this definition is the understanding that if the carrying capacity of the system is exceeded the rate of fish growth will be decreased. Implicit also is the fact that the system must be loaded initially with an amount of fish that, when fed to provide a specified growth rate, the carrying capacity of the system will not be exceeded too soon. Unfortunately, there is no loading method available which takes growth into account.

During the past two decades a great deal of research - both basic and applied - has been conducted on the subject of fish growth (Halver 1972). As a result, the basic nutritional requirements for salmonids and, to some degree, ictalurids have been established. These data, perhaps, do not have too much useful application by the average fish culturist since they feed their fish a commercially prepared ration rather than preparing their own. The concern of the fish culturist is how to feed a prepared diet to produce a fish of desired length and/or weight within a prescribed time period. There have been several methods offered and each merits some consideration.

Schäeperclaus (1933), among the first to offer a method of quantitatively feeding fish, considered the calories required for growth based upon body surface, water temperature, and the hourly caloric intake requirements. He calculated the body surface in square decimeters (1 dm = 10 cm) for trout as being equal to 10 times the body weight in grams to the $2/3$ power. The caloric needs of trout were estimated at 1.44 gram-calories (gcal) per dm^2 per day. Other fish nutritionists have subsequently offered methods of feeding based upon the caloric requirements of fish (Phillips and Brockway 1959; Brown 1957; Winberg 1960; Poloheimo and Dickie 1956, 1966a, 1966b). Application of these methods presumed that the caloric values of the rations were known.

The development of the "hatchery feeding chart", which relates the amount of feed with the fish size and water temperature, removed the necessity of knowing the caloric value of the feed (Deuel, et al. 1937; Deuel, et al. 1952). These charts have withstood the test of time and modifications of the basic charts are currently offered by virtually every fish feed manufacturer for their customers (Table 5). However, use of the chart for feeding fish was considered by some to be too rigid a program to permit inclusion of other variables influencing growth which were unique to one facility or another. To this end, two methods of feeding were offered, either of which allowed the fish culturist the latitude of his particular situation. One was the ΔL , or daily increase in body length, concept (Haskell 1959) and the other was based upon the estimated weight gain (Freeman et al. 1967).

Haskell (1959) considered the major factors affecting fish growth were water temperature, fish species, and feeding rate. His calculations of feeding rate took into consideration and weight-length ratio (K-factor) of the fish, the daily length increase, and the anticipated feed conversion.

Table 5. Recommended feeding rates (lbs feed/100 lbs fish) for salmonids raised in conservation hatcheries. (Modified from the Deuel et al. method.)

Water Temp. (F)	Approximate Size (in.)										
	1	1-2	2-3	3-4	4-5	5-6	6-7	7-8	8-9	9-10	10-
39	3.0	2.5	2.2	1.7	1.3	0.9	0.8	0.7	0.6	0.6	0.5
41	3.3	2.8	2.2	1.8	1.4	1.1	0.9	0.8	0.7	0.6	0.5
43	3.6	3.0	2.5	1.9	1.4	1.2	1.0	0.9	0.8	0.7	0.6
45	4.0	3.3	2.7	2.1	1.6	1.3	1.1	1.0	0.9	0.8	0.7
47	4.3	3.6	3.0	2.3	1.7	1.4	1.2	1.0	0.9	0.8	0.7
49	4.7	3.9	3.2	2.5	1.9	1.5	1.3	1.1	1.0	0.9	0.8
51	5.4	4.5	3.5	2.8	2.1	1.7	1.5	1.3	1.1	1.0	0.9
53	5.6	4.7	3.8	2.9	2.2	1.8	1.5	1.3	1.1	1.1	1.0
55	6.1	5.1	4.2	3.2	2.4	2.0	1.6	1.4	1.3	1.1	1.0
57	6.7	5.5	4.5	3.5	2.6	2.1	1.8	1.5	1.4	1.2	1.1
59	7.3	6.0	5.0	3.7	2.8	2.3	1.9	1.7	1.5	1.3	1.2

Mathematically stated:

$$\text{feeding rate as \% body weight} = \frac{\text{conversion} \times \Delta L \times 3 \times 100}{L}$$

where: ΔL = the daily length increase (in.)

3 = weight-length conversion factor

100 = decimal-removing factor

L = the length (in.) of the fish on the particular day

By assuming that at a constant water temperature, the rate of length increase (ΔL) is constant, then the daily feed rate can be estimated by adding the ΔL to each succeeding daily length. For example, if the ΔL is 0.03"/day and the starting L was 3", then the 10th day L would be $3 + 10(0.03)$ or 10.3".

However, since very few hatcheries have constant water temperature throughout the growing period, Haskell developed a method to adjust the feeding rate estimations according to water temperatures. He found that brook trout growth, for all intents and purposes, ceased at 38.6F and from this developed the concept of the Temperature Unit (T.U.), which was defined as the average water temperature for a month which exceeds 38.6F by 1F. Thus, T.U. = average monthly water temperature ($^{\circ}\text{F}$) - 38.6F. It then follows that an average water temperature of 55F would have a monthly T.U. of 16.4 and an average water temperature of 46.8F would have a monthly T.U. of 8.2. From that, one could say that it would take two months at the lower water temperature to increase the length or weight of the fish and the same as it would increase during one month at the higher temperature. By applying this concept, one can estimate the number of T.U.'s required per inch of gain and then by knowing the expected T.U. during the growth period, the expected growth during the period can be estimated.

Parenthetically, we would like to leave the historical presentation for a bit to amplify Haskell's findings with some current observations. In determining that trout growth virtually ceases at 38.6F, Haskell provided the basis for a valuable concept. Although it has not been stated quantitatively in so many words, each species of fish has a preferred temperature which has been termed the Standard Environmental Temperature (SET). For rainbow trout this has been estimated to be 59F (15C). For years fish culturists have said that for each °F decrease there is a 5% decrease in growth rate in rainbow trout. (For each °C decrease there is a 9% decrease in growth rate.) Accordingly, if the average monthly water temperature decreased by 5F in a succeeding month there would be a 25% decrease in growth rate. This concept concurs with Haskell's T.U. theory very well. Translating this to Pacific salmon is realistically possible. Chinook salmon are considered to have a SET of 54F and their zero-growth level is considered to be 34F; i.e., a 20F drop. The same principle applies to channel catfish and coho salmon, as best as we can estimate.

To remove some of the work in calculating feeding rates by Haskell's method, Buterbaugh and Willoughby (1967) developed a hatchery feeding chart based upon the hatchery constant (HC) concept. They defined the hatchery constant as the numerator of Haskell's equation; i.e., $HC = \text{conversion} \times \Delta L \times 3 \times 100$. For variable water temperatures the expected ΔL is calculated as follows:

$$\Delta L = \frac{\text{T.U. expected (month)}}{\text{T.U. required for 1" growth}} \text{ divided by 30 days}$$

The daily feeding rate is estimated by dividing the hatchery constant by the length (estimated daily) of the fish.

Using the concept of hatchery constant developed by Buterbaugh and Willoughby, Piper (1970) substituted the use of lengthy tables with a slide rule modification. The hatchery constant is set up on the D scale by aligning the index of the CI scale with the selected HC. The length of the fish to be fed is read off the D scale using the sliding hairline. The percent body weight to be fed is read off the CI scale for the appropriate length of fish.

In recent years some facilities have been using computer programming to estimate the daily amount of feed required in a system. None of these, to our knowledge, has been published. They all employ the ΔL concept with the daily increases in length and feed being printed out for each day in the growth period. There have been two major constraints to growth forecasting. The first is obtaining an accurate and realistic growth rate and the second is obtaining accurate input data; i.e., pound-count, head-count, pond weight, and anticipated feed conversion.

References Cited

- Deuel, C.R., D.C. Haskell, and A.V. Tunison. (1937): The New York State fish hatchery feeding chart. New York Conservation Department, Albany, 29 p.
- Deuel, C.R., D.C. Haskell, D.R. Brockway, and O.R. Kingsbury. (1952): New York State Fish Hatchery Feeding Chart, 3rd Ed. N.Y. Conservation Department, Albany, N.Y.
- Elliott, Joseph W. (1969): The oxygen requirements of chinook salmon. *Prog. Fish-Cult.* 31(2):67.
- Freeman, R.I., D.C. Haskell, D.L. Longacre, and E.W. Stiles. (1967): Calculations of amounts to feed trout in hatcheries. *Prog. Fish-Cult.* 29(4):194.
- Halver, J.E., ed. (1972): *Fish Nutrition*. Academic Press, New York and London.
- Haskell, D.C. (1955): Weight of fish per cubic foot of water in hatchery troughs and ponds. *Prog. Fish-Cult.* 17(3):117.

- Haskell, D.C. (1959): Trout growth in hatcheries. New York Fish and Game Journal. 6(2):204-237.
- Liao, Paul B. (1971): Water requirements of salmonids. Prog. Fish-Cult. 33(4):210.
- Piper, R.G. (1970): Know the proper carrying capacities of your farm. Amer. Fishes and U.S. Trout News. 15(1):4.
- Piper, R.G. (1970): Slide rule feeding guide. Progressive Fish-Culturist, 32(3):168-169.
- Piper, R.G. (1972): Managing hatcheries by the numbers. Amer. Fishes and U.S. Trout News, 17(3):10.
- Schäeperclaus, W. (1933): Text Book of Pond Culture. USFWS. Fishery Leaflet 311, 240 pp.
- Westers, H. (1970): Carrying capacity of salmonid hatcheries. Prog. Fish-Cult. 32(1):43.
- Willoughby, Harvey (1968): A method for calculating carrying capacities of hatchery troughs and ponds. Prog. Fish-Cult. 30(3):173.

V. DESCRIPTION OF GENERAL APPROACH TO THE STUDY

A. Background

At the outset of this study the intent was to establish a predictable model for waste product generation for use in any aquaculture system. The further the study progressed the more it became apparent that "the cart somehow had gotten placed before the horse". The subject of growth and growth rates became the central issue rather than the waste products generated.

The design of this study includes 1) a method to evaluate growth of rainbow trout fed commercially prepared diets; 2) the effects of population density and water replacement time on growth; 3) the effects of density and growth rate on oxygen consumption; 4) a method to realistically predict daily solids production in an aquaculture system.

B. Study Approach

1) Fish: Two strains of rainbow trout were used in the study. One was the typical rainbow trout raised at most public and private hatcheries and the other was the Kamloop strain of rainbow trout. Eyed eggs of both strains were obtained from Troutlodge, Tacoma, Washington. The rainbow trout eggs were incubated and raised at the Idaho Department of Fish and Game Hatchery at Hagerman and the Kamloop eggs were incubated and raised in the experimental facilities on the University of Idaho campus.

Both strains of trout performed very well during the course of the study despite the usual mishaps one encounters when using fish as biological research subjects. The most frequent mishap was the plugging of the water inlet with the aquatic slime bacteria, Sphaerotilus sp., which was ultimately controlled by changing water systems. Samples of fish were examined on inventory days for the presence of infectious and noninfectious diseases.

The examinations consisted of the following: gross, wet mounts of gill filaments, hematology, bacteriology, and virology (where indicated).

Population densities were set and maintained in accordance with the individual study protocols.

2) Water: Throughout the study two water temperatures were used, namely: 15C (59F) and 12.5C (55F). The water at the Idaho Department of Fish and Game hatchery at Hagerman was a constant 15C. The experimental facilities on the University of Idaho campus use dechlorinated and filtered (to remove the iron) water which can be heated or chilled to any selected temperature. The dissolved oxygen levels were maintained at both sites in excess of 95% saturation for the elevation and temperature selected.

The water use at the Hagerman facility was single-pass with no reuse while that at the University of Idaho facilities was either a closed system with 10-15% make-up or an open, multiple reuse system. Unfortunately, since the same input parameters were not measured in both the open and closed systems, there could be no determination of the effects of water use on growth.

Water flows were set and maintained in accordance with the individual study protocols.

Sixteen tanks each constructed of $\frac{1}{4}$ -inch plate glass and measuring 18 x 18 x 24 inches, were arranged into two eight-tank systems (Figure 3). Each tank received a regulated amount of water from a head pipe filled under pressure from the hatchery supply. The outflow of each tank was through a Venturi stand-pipe system.

3) Container: In addition, at Hagerman, concrete deep tanks (15' x 32" x 27" water depth or 90 cubic feet) were used in one portion of the study. This was done to compare the growth values obtained in the small units with those obtained in a larger unit.

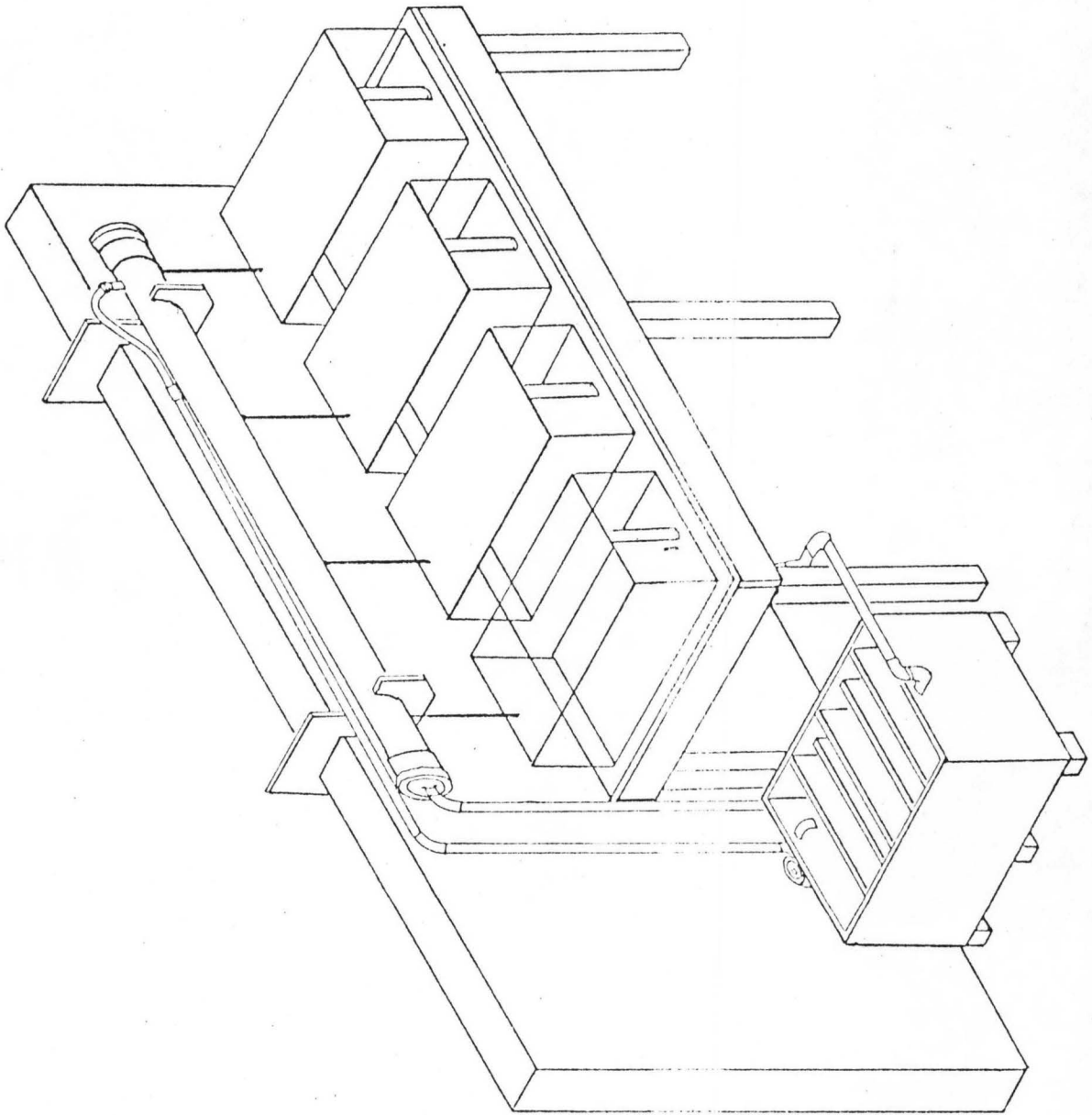

Figure 3. Schematic of a 4 tank system which was expanded to an 8 tank unit for this study. Water use is a closed system with make-up.

4) Nutrition: Commercially prepared diets were used throughout the study. Since the purpose of the study was to test methods of diet evaluation, nutrient utilization, growth rate estimation, and waste product generation and not to compare the relative efficacies of two or more diets, the brand names are unnecessary.

The diets were labelled 'A' and 'B' with the pellet sizes of each listed numerically. During the study, fish were fed four pellet sizes for each diet.

Proximate analyses of freshly prepared feed were conducted by Agra-Test, Inc., Twin Falls, Idaho (Table 6). Also dried fecal samples were analysed for proximate composition (Table 7). Adiabatic bomb calorimetries were conducted on feed and fecal samples at the University of Idaho. In all cases, samples were identified by code designation only.

Fecal samples were collected by two methods. One was a daily collection of the entire fecal load over a 14-day period. This was accomplished by passing the tank outfall through a fine (20 um) mesh sock. The entire daily collection was air-dried in the sock, removed, weighed, and stored frozen until analysed. The other method was to collect spot-samples of feces immediately after passage from the fish. The collection was done with a siphon tube flowing into either a fine mesh sock or into a centrifuge tube. The sample was dewatered by drying in the collection sock or following centrifugation and stored frozen until analysed.

There are several potential sources of error in the fecal collection methods. the major one in the collection of the entire daily load was the possible leach-out of water soluble components plus the growth of bacteria and fungi. This source of error was minimized by frequently changing the collecting socks. Comparing the daily method analyses with the spot-sample method analyses indicated that error was not apparent in proximate composition and gross energy. Also, when comparing the weight of the dried feces to the apparent digestibility coefficients, a surprising degree of correlation was obtained.

Table 6. Proximate analyses of diets.

Diet	% Crude protein	%N	%FAT	%NFE	%FIBER	%ASH	Gross energy (Kcal/g)
A-3	52.5	8.4	10.3	21.4	2.1	13.7	-
4	52.5	8.4	10.3	22.3	2.2	12.7	4.67
5	43.1	6.5	7.3	33.0	4.3	12.3	-
6	44.4	7.1	7.3	31.0	4.9	12.4	4.50
B-2	53.8	8.6	11.5	20.3	1.2	13.2	-
3	50.6	8.1	11.7	22.8	2.3	12.6	4.82
4	46.9	7.5	11.7	28.4	3.8	9.2	-
5	47.5	7.6	10.8	27.9	3.5	10.3	4.72

Table 7. Proximate analyses of feces.

From Diet	% Crude protein	%N	%FAT	%NFE	%FIBER	%ASH	Gross energy (Kcal/g)
A-4	26.9	4.3	4.2	20.7	7.1	41.1	3.10
A-5	36.3	5.8	1.5	35.2	13.6	13.5	-
A-6	25.6	4.1	1.7	37.6	17.3	17.8	3.04
B-3	36.3	5.8	5.8	23.7	13.7	20.6	2.96
B-5	21.3	3.4	3.1	33.8	16.8	25.1	3.14

Nutrition data were analysed using accepted methods in animal nutrition (Church and Pond 1974) and in fish nutrition (Rumsey 1977). The following analytic methods were used:

$$a) \text{ Digestibility (\%)} = \frac{NI - NF}{NI} \times 100$$

where:

NI = total intake (g) of nutrient; i.e., diet, protein, fat, or NFE during a growth period.

NF = total output (g) in feces of nutrient; i.e., diet, protein, fat, or NFE during a growth period.

$$b) \text{ Protein Efficiency Ratio (PER)} = \frac{\text{weight gain (g)}}{\text{protein intake (g) during growth period.}}$$

$$c) \text{ Digestible Energy (DE) as kcal/g of diet} = GE_d - GE_f$$

where:

GE_d = gross energy as kcal/g diet

GE_f = gross energy as kcal/g of feces

$$d) \text{ Total Digestible Nutrient (TDN)} = DCP + DNFE + DCF + 2.25 DEE$$

where:

DCP = digestible crude protein (% or g)

DNFE = digestible NFE (% or g)

DCF = digestible fiber (% or g)

DEE = digestible ether extract (Fats) (% or g)

5) Management: Growth rates were programmed for 14-day periods using either the OWRT computer program (Appendix II) or the BROCK computer program (Appendix III). A third computer program (IRV) was developed from the data obtained from this study but has not been tested under field conditions (Appendix IV).

The OWRT program is a specialized program in which fish are raised to attain the maximum population density (based upon Density Index or life support) at the end of each growth period. It has very little application outside this study.

The BROCK program was designed to permit the user a choice of methods to determine carrying capacity; i.e., Piper Flow Index method, Liao Oxygen Consumption method, Willoughby Feeding Rate method, Pond Loading Index method, Piper Density Index method, and Westers' Water Replacement Time method (Appendix I). All these methods except the Pond Loading Index method (PLI) have been discussed in Section IV. The PLI method was developed and tested during this study. The input feeding rate was based upon Haskell's ΔL concept which implies that a reasonable growth rate must be estimated. The program will print out daily pond weight, no./lb, length (in.), feeding rate, lbs of feed, and head count. If the average daily mortality can be estimated, it will be considered in the daily print-out for the growth period. The program is designed to have maximum loading at the end of the growth period and initial loading is back-calculated within the program. That is, at the end of the growing period, it will be necessary to remove fish from the pond.

The IRV program is similar to the BROCK program except that it will print-out a daily solids (lbs/100 lbs of fish), daily $\text{NH}_3\text{-N}$ (mg/l), and daily free- NH_3 (mg/l). The ammonia-N calculations are based upon the method by Willoughby et al. (1972) using the NH_3 association-dissociation table by Trussell (1972). The solids calculation is based upon the method developed during this study (Appendix VI).

At the end of a 14-day period, tank or pond inventories were conducted using both sample counting techniques and whole population inventory methods. A comparison of the two methods will be presented.

Feeding frequencies (number of feedings per day) were dependent upon the size of the fish being fed and the feeding rate. Small fish on a high feeding level received more frequent feedings each day than did either the same size

fish on a lower feeding rate or larger fish at the same growth rate. The reason for this was based upon the smaller stomach capacity in the small fish.

Estimations of growth rate were, at the outset, based upon 80% and 90% of the growth rate considered to be maximum at the particular water temperature. Later in the study another method of estimating growth rate was tested and found to be promising.

References Cited

- Church, D.C. and W.G. Pond (1974): "Basic Animal Nutrition and Animal Feeding". Publ. D.C. Church, Corvallis, Oregon. 300 pp.
- Rumsey, G.L. (1977): Fish nutrition - recent advances. Proc. International Symp. on Dis. of Cultured Salmonids, Seattle, Wash. April 4, 5, 6, 1977. Publ. Tavolek, Inc., Seattle, Washington.
- Trussell, R.P. (1972): The percent un-ionized ammonia in aqueous ammonia solutions at different pH levels and temperatures. J. Fish. Res. Board Canada 29(10):1505.
- Willoughby, Harvey, Howard N. Larsen, and J.T. Bowen (1972): The pollutional effects of fish hatcheries. Amer. Fishes and U.S. Trout News. 17(3):16.

VI. THE EFFECT OF DENSITY AND GROWTH RATE ON THE
WEIGHT-DEPENDENT OXYGEN CONSUMPTION: A STUDY

A. Background

In the past 25 years, the relation of body weight to oxygen consumption in fishes has received a great deal of attention (Job 1955, 1959, 1969; Winberg 1956; Fry 1957; Basu 1959; Beamish 1964(a), (b); Beamish and Mookhergii 1964; Brett 1964, 1965; Kutty 1968; Elliot 1969; Liao 1971). However, very little of this work has dealt with the metabolic response of fishes to various densities and growth rates, two of the most important factors dealt with in fish culture. They give rise to questions such as: "Will the added stress on fish held at high density cause them to use more or less oxygen per unit biomass than the same fish held at lower density?" "Do fish growing at a high rate require more oxygen than do fish growing at a low rate?" These two questions must be answered to help fish culturists better understand the needs of the fish being reared. The purpose of this study is to determine the effects of density, growth rate, and the interactions between density and growth rate on the oxygen consumption of rainbow trout.

The study was also designed to test the efficacy of a new method of determining oxygen uptake. Most of the published studies were conducted using specially constructed respiratory chambers into which a small number of fish could be placed and allowed to acclimate for 8-48 hours. The practice of moving fish from their normal environment, be it hatchery rearing pond or stream into a completely new and different environment to do oxygen consumption tests has been questionable. A three-fold increase in oxygen consumption by tench after transference from a pond to a barrel was shown by Schaeperclaus (1933). This suggested that a change in environment caused stress or excitement leading to a very large change in the fishes oxygen requirements.

In this study, a new approach was used to remove handling stress and the need for adaption to a new environment as possible sources of error. The oxygen consumption tests were run with the entire lot in the same tanks in which they were being reared. Standard hatchery conditions were duplicated as much as possible, so that the data gathered could actually be used in a field situation.

B. Study Approach

1) Experimental Fish: Rainbow trout, obtained from the Idaho Department of Fish and Game trout hatchery at Hagerman, were from two separate lots being reared there at the time. The lots were labelled A and A', with lot A fish having an average initial weight of 4.340 grams and lot A' fish having an average weight of 0.387 grams. The fish were reared through four two-week periods.

2) Fish Holding Facilities: These were described in section V.

3) Oxygen Consumption Procedure: The oxygen consumption tests were run during the afternoon preceeding an inventory sampling day. The fish were not fed 20 to 22 hours prior to being tested. For two weeks before and during the test, the fish were not handled. A YSI Dissolved Oxygen Meter (Model 54 ARC) and probe were used to measure oxygen uptake in the tank. The test tank was filled with water, then sealed with a special glass lid, the inside of which was covered with porous foam rubber which allowed water to penetrate thereby moving the air-water interface out of the fish's range (Figure 4). The lid also had a hole drilled in the center to allow entry of the oxygen probe. Readings of dissolved oxygen were taken initially then at ten-minute intervals until either the dissolved oxygen had reached a level of 4 mg/liter or 30 minutes had passed. The oxygen consumptions in mg oxygen per kg of fish per hour and mg oxygen per hour were

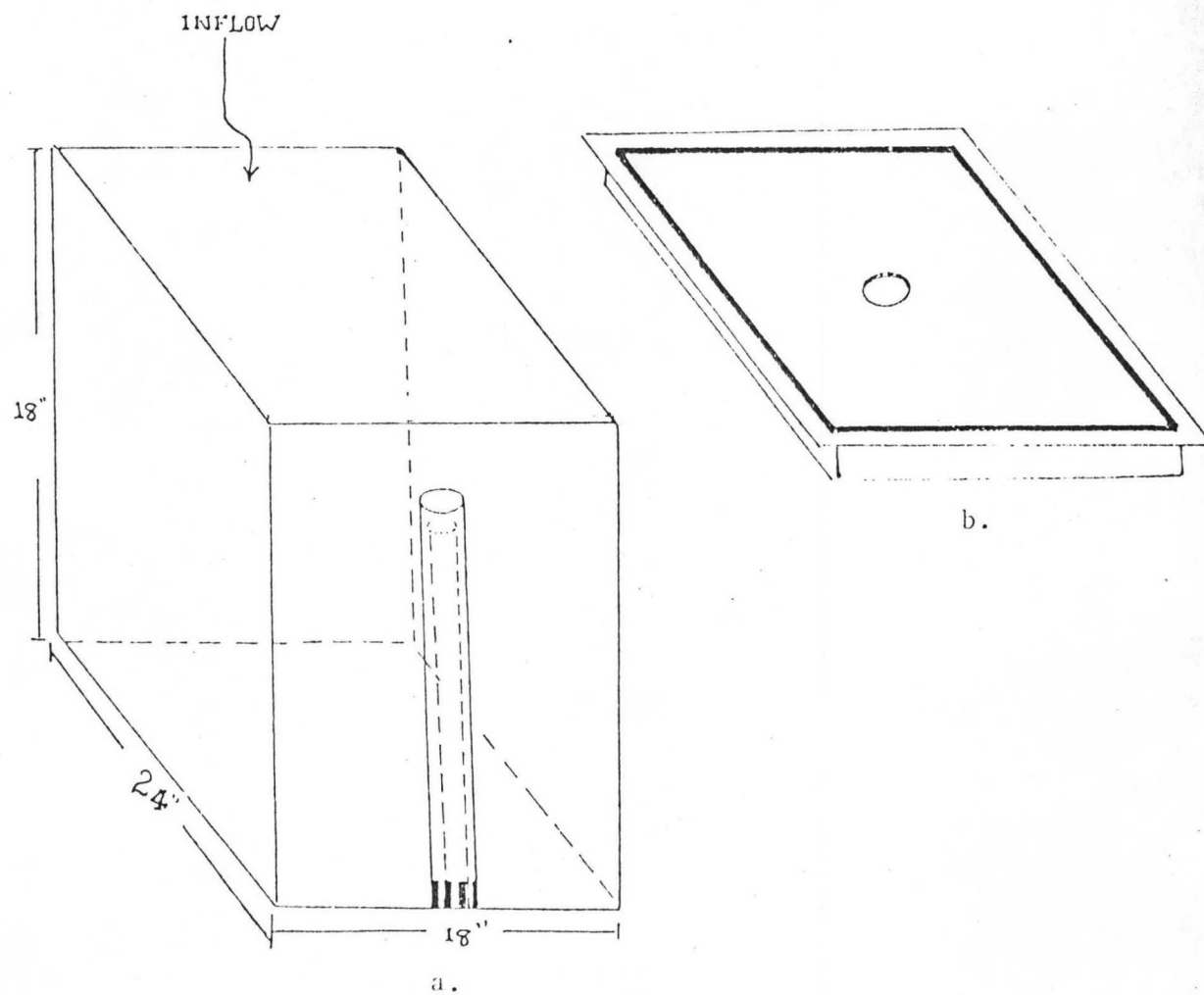

Figure 4. Schematic diagram showing rearing tank (a), and oxygen consumption lid (b).

computed as follows:

$$\text{mg } O_2/\text{hr} = \frac{(V(O_i - O_f)) (60/t)}{N}$$

$$\text{mg } O_2/\text{Kg fish/hr} = \frac{(V(O_i - O_f)) (60/t)}{B}$$

Where:

V = volume of water in the test tank
in liters;

O_i = initial oxygen level in mg/liter;

O_f = final oxygen level in mg/liter;

N = number of fish in the tank;

B = biomass of fish in the tank in kilograms;

t = time between the initial and final oxygen
readings in minutes.

4) Experimental Design: Three variables were introduced into each system; namely: Maximum Density Index (MDI), feed rate (R_f), and water inflow (R_w). Two density levels were tested, 0.2 and 0.5 pounds of fish per cubic foot per inch of body length. These densities were selected to represent that typical of a conservation hatchery (0.2) and that of a commercial hatchery (0.5).

Two growth rates were selected because fish culturists must sometimes either increase or decrease growth rates in the fish they are rearing. Assuming maximum growth for rainbow trout to be 1.5 inches per month at 15C, the two groups were fed to attain 70% and 90% of this, or 1.05 and 1.35 inches per month (corresponding to daily growth of 0.035 and 0.045, respectively). A food conversion of 1.2 was assumed for the smaller fish and 1.5 for the larger

fish. The fish were fed a commercially prepared diet several times daily.

Water inflow (in gpm) was determined using the newly developed Pond Loading Index formula (cf Section VII). This permits adjustment of the inflow to meet the life support requirements of the fish in the pond. For example, in two identical ponds, one loaded at a density of 0.2 and the other at 0.4 pounds per cubic foot per inch of body length, all other factors constant, the first pond would require half the life support of the second pond. All possible combinations of density, feed rate, and inflow were made in at least one tank, but in this study, only tanks which had the water inflow adjusted to meet life support were used.

The fish were sampled every two weeks for weight gain, length gain, gill condition, number per pound, and dietary efficiency. The day before sampling the fish received no feed and it was on this day that oxygen consumption tests were run. Data collected were processed through the University of Idaho Computer Center by means of an on-site portable computer terminal. The program used had been specifically written for this study (Appendix II) and performed all of the pond loading and feeding calculations needed for the next two-week period (Appendix V). Fish were removed from each tank to maintain the specified Maximum Density Index. The tanks were cleaned daily and the fish fed eight to ten times daily.

C. Results and Discussion

The general equation relating metabolic rate (Y , mg oxygen/hour) to weight (X , grams) has been expressed as $Y = aX^b$, or $\log Y = \log a + b \log X$ (Brett 1965). Using this transformation with the oxygen consumption data collected, and using a standard least squares regression, the slope values (b , the rate of change of metabolic rate with size) can be computed. The data were also subjected to a factorial analysis of covariance (Steel and Torrie 1960). If

all the data are treated together, a b-value of 0.8423 is the result. Slopes or b-values for high and low density as well as high and low feed rates are also found in Table 8.

These data are in agreement with those found in literature for fishes. Lagler et al., (1977) states that b-values between 0.6 and 1.0 are common for fishes. Barrett (cited by Fry 1957) obtained a slope of 0.8 for rainbow trout, as did Coche (1967), who reported a slope value of 9.8 for steelhead (Salmo gairdneri). Brett (1965) reported a slope value of 0.778 at 15C in fresh water for Oncorhynchus nerka. Huesner et al., (cited by Madan Mohan Rao 1971) obtained mean slope values of 0.7, 0.8, and 0.7, at 25C for three species. Madan Mohan Rao (1971) reports b-values of 9.7838 in 5C fresh water and 0.7834 in 15C fresh water for rainbow trout. Beamish (1964b) and Beamish and Mookherjee (1964) cited b-values of 0.88 for Salmo trutta, 1.05 for Salvelinus fontinalis, 0.86 for Catostomus commersoni, 0.93 for Ictalurus nebulosus, and 0.85 for Carrassius auratus (overall mean of 0.9).

The close correlation between our findings and those of other studies has a dual meaning; it corroborates the methods used in previous work and validates the results of the new oxygen consumption method. This indicates that eight to 48 hours was indeed enough time for the fish to become acclimated to their new environment, and that the procedure used in this study provides a new and accurate method of determining oxygen consumptions. Our new oxygen consumption procedure allows testing the effects of various fish culture manipulations on oxygen consumption in a simulated hatchery pond. This procedure also eliminates the need for using more expensive respiratory flow chambers.

Table 8. Equations for relationship between metabolic rate (Y, mg O₂/hour) and weight (X, grams) at different levels of density and feed rate. Also included is an equation for a combination of all data gathered.

Variable	Equation	Correlation (r)
Low Density	$\log Y = -0.3204 + 0.8441 \log X$	0.9884
High Density	$\log Y = -0.2865 + 0.8165 \log X$	0.9943
Low Feed Rate	$\log Y = -0.3022 + 0.8106 \log X$	0.9904
High Feed Rate	$\log Y = -0.3224 + 0.8699 \log X$	0.9941
Combined	$\log Y = -0.3128 + 0.8423 \log X$	0.9916

1) The Effect of Density on Oxygen Consumption: It can be seen from the graphic presentation of the data that the rate of oxygen consumption at both densities is virtually the same (Figure 5). The factorial analysis of covariance run on the data showed no significant effect ($P < 0.01$) on oxygen consumption by the change in density. The F-value obtained was 1.57, which shows that there is no significance at the 99 percent level.

Rainbow trout are a territorial fish and the data indicate that territoriality was not broken down even at the high density level. This conclusion is supported by actual observation of fish behavior in both the high and low density tanks. If territoriality were broken down it is assumed that oxygen consumption would increase due to increased activity and stress on the fish. One might also assume that because the fish in the low density tanks would have larger territories they would move around more or be more active in the territory thereby using more oxygen, but this is apparently not the case.

2) The Effect of Growth Rate on Oxygen Consumption: Growth rate has little or no effect on the rate of oxygen consumption (Figure 6). Statistical analysis of the data provided an F-value of 0.0 for the effect of growth rate on the rate of oxygen consumption. An F-value such as this indicates that there is absolutely no effect on oxygen consumption caused by the change in

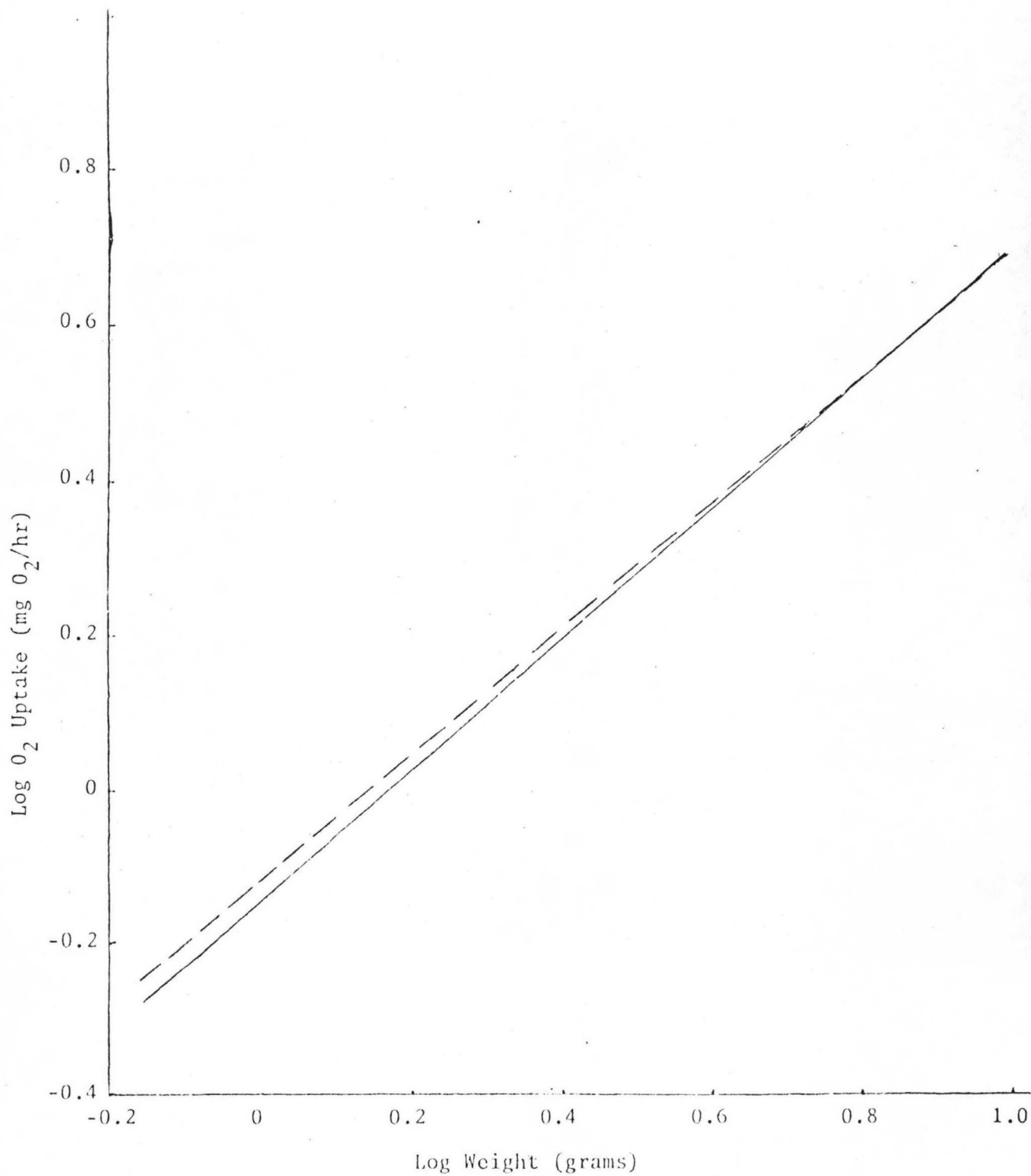

Figure 5. Size-metabolism curves for fish held at high density (0.5 lb./cubic foot/inch) and low density (0.2 lb./cubic foot/inch). Solid line is low density and dotted line is high density.

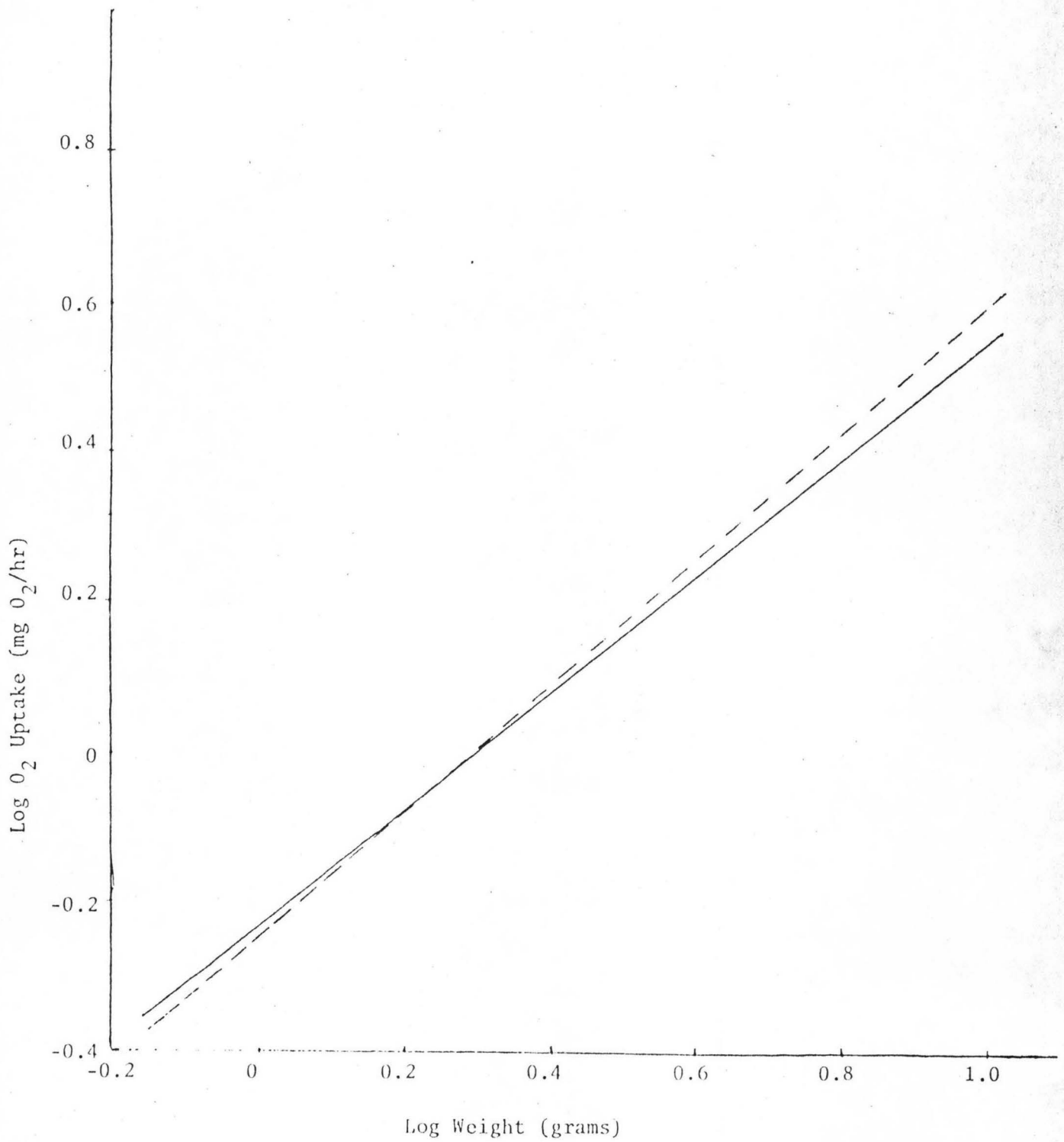

Figure 6. Size-metabolism curves for fish fed at high (daily growth factor of 0.045 inches) and low (daily growth factor of 0.035 inches) feed rates.

growth rate from high to low. This can be explained by the fact that the fish had been starved for between 20 to 22 hours before oxygen consumption tests were run. We believe that this timing factor was sufficient under our given water temperature (15C) to allow metabolism to reach a baseline level which was virtually identical for the high and low growth rates. Wells (1935) did not find a significant change in the rate of oxygen consumption of Girella nigricans beyond 24 hours of starvation. No further change in the rate of oxygen consumption could be detected after two days of starvation by Moss and Scott (1961). Beamish (1964a) stated that a comparison of the average routine and average standard rates of oxygen consumption indicates that, at both levels of activity, oxygen consumption decreased with starvation during the first two or three days. Beyond this there was no further decrease at the standard level, whereas average routine oxygen consumption continued to decrease although not at as high a rate.

3) The Effect of the Interaction Between Density and Growth Rate: There was no significant effect ($P < 0.01$) on oxygen consumption caused by any interaction between growth rate and density (the F-value as determined by statistical analysis was 0.808).

D. Implications

Oxygen uptake per unit biomass decreases as individual fish weight increases (Figure 7). This was also found by Brett (1965), Madan Mohan Rao (1971), and Elliot (1969). For example, a kilogram of 5 g fish would use 64.2 mg more oxygen per hour than 1 kg of 15 g fish. Taking this into consideration, caution should be used in loading ponds with fish of different size. Available oxygen has to be a consideration in pond loading calculations. For example, in a raceway (8 x 80 x 3 feet) with an inflow of 1.07 cfs and 2.5 turnovers per hour, with a dissolved oxygen level at the inflow of 9.0 mg/l

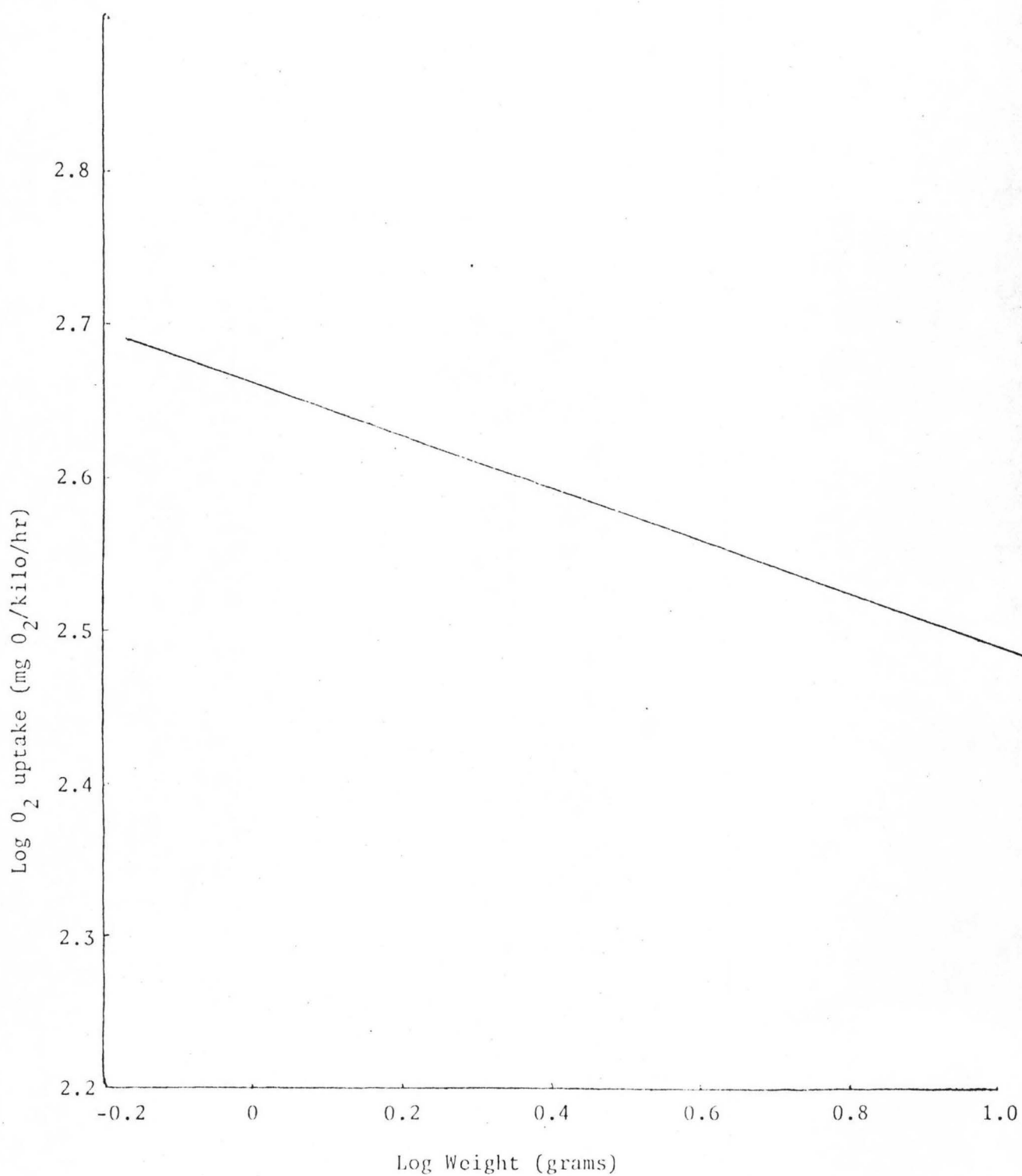

Figure 7. Size-metabolism curve for the relation between oxygen uptake per kilogram regardless of density or feed rate. ($\log Y = 2.695 + -0.17 \log X$)

and a minimum dissolved oxygen level at the outflow of 5.0 mg/l, there would be 544,372 mg of oxygen available for utilization. This pond could support 1741.0 kg of 15 g fish but only 1444.0 kg of 5 g fish. Relating this to Piper (1972) this pond could support a density of 0.553 lb/cu.ft./in. of 5 g fish and only 0.465 lb/cu.ft. ft/in. of 15 g fish (based on a K-factor of 0.00041). If the dissolved oxygen were dropped only 1 mg/l, it would drop the life support in the pond to a level that would only support 0.415 lb/cu.ft./in. of 5 g fish and 0.349 lb/cu.ft./in. of 15 g fish.

E. Conclusions

- 1) There is no significant effect ($P < 0.01$) on the rate of oxygen uptake between densities of 0.2 and 0.5 lb/cu.ft./in. of body length.
- 2) Rainbow trout held in 15C water and starved for 20 to 22 hours prior to testing for oxygen consumption show no significant difference ($P < 0.01$) in rate of oxygen consumption caused by the difference between high ($\Delta L = 0.045$ inches) and low ($\Delta L = 0.035$ inches) growth rates.
- 3) The interaction between growth rate and density causes no significant ($P < 0.01$) change in the rate of oxygen consumption.
- 4) Per unit biomass, smaller fish use more oxygen than do larger fish.
- 5) Metabolic rate is reduced to the same baseline after 20 to 22 hours of starvation whether the fish were on a high or low growth rate.

References Cited

- Basu, S.P. (1959): Active respiration of fish in relation to ambient concentrations of oxygen and carbon-dioxide. J. Fish. Res. Bd. Can. 16, 175-212.
- Beamish, F.W.H. (1964a): Influence of starvation on standard and routine oxygen consumption. Trans. Am. Fish. Soc. 93, 103-107.

- Beamish, F.W.H. (1964b): Respiration of fishes with special reference to standard oxygen consumption. II. Influence of weight and temperature on respiration of several species. *Can. J. Zool.* 42, 177-188.
- _____ and P.S. Mookherjee (1964): Respiration of fishes with special emphasis on standard oxygen consumption. I. Influence of weight and temperature on respiration of the goldfish, Carassius auratus. *Can. J. Zool.* 42, 161-176.
- Brett, J.R. (1964): On respiratory metabolism and swimming performance of young sockeye salmon. *J. Fish. Res. Bd. Can.* 21, 1183-1226.
- _____. (1965): The relation of size to rate of oxygen consumption and sustained swimming speed of sockeye salmon (Oncorhynchus nerka). *J. Fish. Res. Bd. Can.* 22, 1491-1501.
- Coche, A.G. (1967): Oxygen consumption as related to body size in juvenile steelhead, Salmo gairdneri (Richardson). *Hydrobiologia* 29, 165-184.
- Elliot, J.W. (1969): The oxygen requirements of chinook salmon. *Prog. Fish-Cult.* 31(2):67.
- Fry, F.E.J. (1957): Aquatic respiration of fish. In: Physiology of Fishes, Vol. 1, pp. 1-63. Ed. by M.E. Brown. New York: Academic Press.
- Haskell, D.C. (1955): Weight of fish per cubic foot of water in hatchery troughs and ponds. *Prog. Fish-Cult.* 17(3):117.
- Job, S.V. (1955): The oxygen consumption of Salvelinus fontinalis. *Publ. Ont. Fish. Res. Lab.* 73, 1-39.
- _____. (1959): The metabolism of Plotosus anguillaris (Bloch) in various concentrations of salt and oxygen in the medium. *Proc. Indian Acad. Sci.* 5 (C), 267-288.
- _____. (1969): The respiratory metabolism of Tilapia mossambica (Teleostei). I. The effect of size, temperature and salinity. *Mar. Biol.* 2, 121-126.
- Kutty, M.N. (1968): Respiratory quotients in goldfish and rainbow trout. *J. Fish. Res. Bd. Can.* 25, 1689-1728.
- Lagler, K.F., Bardach, J.E., Miller, R.R., Passino, D.R.M. (1977): 2nd Ed. Ichthyology. John Wiley and Sons. pp. 230-233.
- Liao, P.B. (1971): Water requirements of salmonids. *Prog. Fish-Cult.* 33(4):210.
- Madan Mohan Rao, G. (1971): Influence of activity and salinity on the weight-dependent oxygen consumption of the rainbow trout Salmo gairdneri. *Marine Biology* 8, 205-212.

- Moss, D.D. and Scott, D.C. (1961): Dissolved oxygen requirements of three species of fish. *Trans. Am. Fish. Soc.* 90(4):377-393.
- Piper, R.G. (1972): Managing hatcheries by the numbers. *Amer. Fishes and U.S. Trout News.* 17(3):10.
- Schäeperclaus, W. (1933): Textbook of Pond Culture. U.S. Fish and Wildlife Service, Fishery Leaflet. 311, 1-240.
- Steel, R.G.D. and Torrie, J.H. (1960): Principles and Procedures of Statistics. 481 pp. McGraw-Hill Book Co., Inc.
- Wells, N.A. (1935): Variations in the respiratory metabolism of the Pacific killifish, Fundulus parvipinnis, due to size, season and continued constant temperature. *Physiol. Zool.*, 8:318-337.
- Winberg, G.G. (1956): Rate of metabolism and food requirements of fishes. *Belorussk. med. Dumka* 1-251. (Transl. Fish. Res. Bd. Can. No. 194).

VII. EVALUATION OF GROWTH DATA: A METHOD

A. Background

Any hatcheryman who has dealt with pond inventory records knows, firsthand, the frustration of not knowing exactly the numbers of fish or the total weight of fish in a pond. Most will agree that a (+) or (-) 5% discrepancy between what is in the pond and what is on the record would be nice; but the discrepancy is often (+) or (-) 15-20%. As it turns out, the results of this study improved somewhat on the error; but the error is still there and must be dealt with since the over-all predictability and output are affected by the error.

The data used to evaluate growth rates were obtained from raising groups of rainbow trout in four 90 cu.ft. concrete tanks. Two groups were designated as the S-series, one of which was designated as S-A and the other S-B. Two groups were designated as the L-series, one of which was designated as L-A and the other L-B. The 'S' designated small fish and the 'L' designated large fish. The 'A' designated one diet and 'B' another diet, both commercially available. During the four biweekly growth periods the S-A group were fed diets A-3 and A-4, which indicates pellet sizes. The S-B group was fed diets B-2 and B-3. The L-A group was fed diets A-5 and A-6. The L-B group was fed diets B-4 and B-5. All groups were fed at a level to increase the length during each 14-day period by 0.56 in. (1.422 cm). The feed conversions expected were: 1.2 for diets A-3, A-4, B-2, and B-3; 1.5 for diets A-5, A-6, B-4, and B-5. The water (15C) flows were adjusted to two change-overs per hour. The OWRT feeding program was used throughout the four growth periods. Initial and biweekly inventories were accomplished as follows:

- a. Initial and subsequent pound counts (no./lb) and individual lengths (mm) at the end of each growth period were taken by "herding" the fish to the inflow end of the tank with a large dipnet and removing each sample from the middle of the group (Tables 9 and 10).
- b. Weights of biomass (lbs) were done initially and at the beginning of each growth period. The starting biomass in each growth period was done by the weight-in method rather than the weight-out method; i.e., fish were weighed into a pond rather than removing a calculated weight from the pond. Thus, the actual weight at the start of each growth period was known.
- c. The biweekly data were recorded on a summary form especially designed for this study (Table 11) and transferred to a data compilation form (Table 12) for analyses.

B. Results and Discussion

Upon reviewing the compiled data (Table 12) the age-old problem of discrepancy between estimated and actual numbers of fish and total biomass is present. Column 13 indicates that there is a 8.8% to -9.9% population difference between weights calculated from initial pound-counts and weights calculated from ending pound-counts. The net difference for the four growth periods for each group ranged from -2.99% to -17.32%. The comparisons between the total estimated weight gain (Columns 4 minus 3) and the actual total weight gain during the four periods are less dramatic; i.e., -2.28% to -6.85%. What is indicated by both comparisons - numbers and weight - is that sampling errors were significant.

If it is assumed that 1) the pound-counts are accurate; 2) the mortalities are accurate; 3) the actual weights are accurate; then, the head counts are accurate. But, the pound-counts at the end of each periods multiplied by the weight at the end of each period does not equal the estimated head-count

Table 9. S-series sample sizes.

Period	No. measured	Sample Wgt. (No./lb.)	No. samples (No./lb.)
Initial	44	200-400 g	5
1	44	200-400 g	4
2	44	1 lb	4
3	44	1 lb	5
4	44	2 lbs	4

Table 10. L-series sample sizes.

Period	No. measured	Sample Wgt. (No./lb.)	No. samples (No./lb.)
Initial	22	1 lb	5
1	22	1 lb	5
2	44	1 lb	5
3	44	2 lbs	5
4	44	2 lbs	5

Table 11. Exhibit of biweekly data recording form.

BIWEEKLY POND SUMMARY

Pond No. _____

Sample Date _____

Lot No. _____

Date of Last Sample _____

1. Number/lb at start		16. Growth	
2. Number/lb at end		17. Number of days	
3. Number/lb gain		18. Growth/day	
4. Number at start		19. Flow (GPM)	
5. Loss		20. Velocity (ft/sec)	
6. Number at end		21. Pounds/gallon/min.	
7. Weight at start		22. Pond Loading Index (lbs/pond/in)	
8. Weight at end		23. Pounds cubic foot	
9. Gain		24. Maximum Density Index (lbs/pond/in)	
10. Food fed		25. Temp (°C)	
11. Conversion		26. Temp units/in.	
12. Cost of food (¢/lb)		27. Oxygen (mg/l)	
13. Cost of fish/lb gain		28. K-factor ($\times 10^{-4}$)	
14. Length at end (mm)		29. Pond Constant - estimated	
15. Length at start (mm)		- actual	

Table 12. Biweekly inventory data from each of two size groups of rainbow trout split into two diet groups.

Parameter	No./lb.		Weight (lb.)					Population (nos.)					
	Column 1	Column 2	Column 3	Column 4	Column 5	Column 6	Column 7	Column 8	Column 9	Column 10	Column 11	Column 12	Column 13
Calc. Method	Start	End	Start	End	Gain	End	Gain	Start	Morts	End	End	Diff.	%
	Direct	Direct	Direct	(10/2)	(4-3)	Direct	(6-3)	(1x3)	Direct	(8-9)	(2x6)	(11-10)	(12/10)
Size-Diet-Period													
Small A-1	583.43	365.63	22.36	35.45	13.09	38.60	16.24	13,047	85	12,962	14,114	+1152	+ 8.89
2	365.92	223.00	21.37	34.96	13.59	31.50	10.13	7,813	21	7,797	7,025	- 772	- 9.90
3	223.11	131.20	27.66	46.95	19.29	42.90	15.24	6,172	12	6,160	5,629	- 531	- 8.62
4	131.06	91.75	32.07	45.77	13.70	48.80	16.73	4,203	4	4,199	4,478	+ 279	+ 6.64
Small B-1	583.43	333.28	22.36	38.92	16.56	40.40	18.04	13,047	76	12,971	13,465	+ 494	+ 3.71
2	333.73	193.75	22.17	38.12	15.95	34.40	12.23	7,398	12	7,386	6,665	- 721	- 9.76
3	193.94	116.64	27.78	46.29	18.51	46.00	18.22	5,387	8	5,397	5,364	- 33	- 0.61
4	116.64	76.40	33.41	50.92	17.51	50.60	17.19	3,896	6	3,890	3,866	- 24	- 0.62
Large A-1	94.71	75.01	29.82	37.50	7.68	35.30	5.48	2,824	12	2,812	2,648	- 164	- 5.83
2	74.98	60.06	34.50	41.90	7.40	41.40	6.90	2,587	92	2,495	2,484	- 11	- 0.44
3	60.06	43.00	30.65	42.50	11.85	36.60	5.95	1,841	14	1,827	1,574	- 253	-13.85
4	43.00	33.50	33.68	42.70	9.02	43.90	10.22	1,448	17	1,431	1,471	+ 40	+ 2.80
Large B-1	94.71	70.81	29.82	39.73	9.91	38.10	8.28	2,824	11	2,813	2,697	- 116	- 4.12
2	70.81	45.80	36.13	54.96	18.83	48.90	12.77	2,588	41	2,517	2,240	- 277	-11.01
3	45.86	35.77	31.60	40.02	8.42	41.90	10.30	1,447	14	1,433	1,500	+ 67	+ 4.68
4	35.77	26.00	36.82	50.23	13.41	52.80	15.98	1,317	11	1,306	1,373	+ 67	+ 5.13

(Col. 10 vs. Col. 11); nor does the head-count at the end of the period (Col. 10) divided by the pound-count at the end of the period equal the actual weight at the end of the period (Col. 4 vs. Col. 6). Therefore, 1) the pound-counts are in error and the weights are correct; 2) the weights are in error and the pound-counts are correct; 3) both the weights and pounds are in error.

Some insight into the foregoing deductive logic was accomplished by ordering the lengths (mm) of sampled fish and determining the range, mid-range, median, and mean for each sample (Table 13). By assuming a normal, symmetrical distribution of lengths within a population and that, if this were the case, there would be similarity among the mid-range, median, and mean lengths. Testing this assumption indicated that 88.9% of the fish measured would fall within 95% of equality in their respective groups and that 100% of the fish would fall within 93.8% of equality. Thus, there were sampling biases in each inventory but within each group they tended to be mutually exclusive during the four growth periods.

In addition, the greater the length range the more likely the sample would be size selective, thus, the larger the pound-count bias. The following are methods of correcting the pound-counts to remove the sampling bias:

$$a) \text{ Corr. no./lb} = (\text{mean/mid-range}) \times \text{no./lb}_{\text{obs}}$$

Assumes a symmetrical distribution of length in the initial population.

$$b) \text{ Corr. no./lb} = \left(\frac{\% \text{ inequality}_{\text{end}}}{\% \text{ inequality}_{\text{start}}} \times \% \text{ inequality}_{\text{end}} \right) \times \text{no./lb}_{\text{end}}$$

Assumes an asymmetrical distribution of length in the initial population which is treated as unity with respect to % equality.

$$c) \text{ Corr. no./lb} = \text{no./lb off K-factor (0.0004) table using length (mm) as the input.}$$

Assumes that the length-weight comparisons within the sample were biased by the distribution of length within the sample.

Table 13. Length sampling data of rainbow trout on programmed growth.

Unit	n	Length				No./lb
		Range (mm)	Mid-range (mm)	Median (mm)	Mean (mm)	
S-A-0	44	19	39.5	43	42.1	583.4
1	44	19	48.5	50	49.9	365.9
2	44	23	59.5	60	60.3	223.
3	44	24	67	67	67.27	131.0
4	44	50	75	77.5	76.5	91.75
S-B-0	44	19	39.5	43	42.1	583.4
1	44	23	51.5	51.5	51.3	333.7
2	44	19	58.5	60	60.3	193.9
3	44	28	71	69	69.5	116.6
4	44	30	80	80	80.1	76.4
L-A-0	22	36	73	70.5	73.4	94.7
1	22	44	81	83.5	81.9	74.9
2	44	34	91	90	91.45	60.0
3	44	65	97.5	95	95.9	43.0
4	44	65	97.5	103.5	102.5	33.5
L-B-0	22	36	73	70.5	73.4	94.7
1	22	30	85	85	84.9	70.8
2	44	54	96	92	91.5	45.9
3	44	66	109	101.5	103.1	35.8
4	44	80	122	116.5	117.2	26.0

After applying each method to the data (Table 12) it was concluded that none would suffice to diminish the disparity already present. Method (b) did diminish the net error in the four growth periods in each group; however, the biweekly error was still quite significant.

From this study, the following recommendations may be made (but remain to be tested):

- a. Determine the length (mm) frequency, distribution, range, mid-range, mean, and median at each sampling. Unity of the mean and median are both more significant than unity among mean, median and mid-range because mid-range values are from two extremes.
- b. Crowd the fish to one end of the pond with a screen rather than "herding" them with a net. This will minimize the size selection bias.
- c. Grade the fish when the length range exceeds 50% of the length range of the previous period. After grading, a new length distribution and pound-count must be done.
- d. Weigh the fish into the pond rather than removing a certain weight to reduce the biomass to the prescribed level.
- e. Determine the biomass (weigh all fish) at the end of every second growth period.
- f. For sample weighing small fish (1.5-3 in.) use a metric beam balance rather than an avoirdupois spring scale. For fish more than 3 in. long an avoirdupois scale with 0.01 lb accuracy may be used. Also, at each sampling, the balance or scale should be calibrated using at least three reference weights covering the range of the samples to be weighed. Samples of small fish should be weighed to the nearest 0.5 g (0.0011 lb), 3"-6" fish samples should be weighed to the nearest gram (0.0022 lb), and samples of fish more than 6" should be weighed to the nearest 10 g (0.022 lb). Recall that 1 oz. equals 28.5 g; thus, if a one pound sample were

weighed to the nearest ounce the error will be 6.3% while the error for weighing to the nearest 10 g will be 2.2%.

g. In sampling fish for no./lb estimates, a minimum of five samples should be weighed and counted. Each sample should contain 150-250 fish. There should be at least a 90% agreement among the individual pound-counts. The most accurate pond-count will be obtained by dividing the total fish counted by the total weight rather than calculating the mean no./lb from each pound-count.

VIII. EFFECTS OF POPULATION DENSITY AND
WATER REPLACEMENT TIME ON GROWTH: A STUDY

A. Background

As has been stated previously, there are many factors on an aquaculture system which can affect growth. This portion of the study was designed to test a method of determining the optimum biomass in a system permitting growth to occur without being affected by either population density or water replacement time.

The method, designated the Pond Loading Index (PLI), was derived from applying Piper's F (lbs of fish per gpm per in. body length) to Westers' method for carrying capacity (cf Appendix I). Piper's Flow Index method considers carrying capacity from the standpoint of water inflow and does not consider the volume of rearing space. It was assumed that F was fairly accurate although it was derived empirically from a single value; namely, 1.5 lbs/gpm/in. This value was found to permit good growth of fish in 50F water at an elevation of 5000' above mean sea level (MSL). A table of F-values (Table 14), taking into account the effect of temperature on metabolic rate and the effect of elevation and temperature on the dissolved oxygen level in water, assumed that; a) for each $^{\circ}$ F increase from 50F there would be a 4% increase in growth rate and carrying capacity; b) for each $^{\circ}$ F decrease from 50F there would be a 5% decrease in growth rate and carrying capacity; c) for each 1000' decrease in elevation there would be a 4% increase in carrying capacity due to the additional dissolved oxygen (Piper 1970).

Westers' Water Replacement Time method considers carrying capacity as a function of water replacements per hour and volume of rearing space. However, Westers' method of determining the baseline pounds of fish by size groups is subject to some error in that it must be read from a graph (Westers 1970).

Table 14. Load Factors (lbs fish/inch of length/gpm) for trout and salmon as related to water temperature and elevation.

Water temperature F ^o	0	1000	2000	3000	4000	5000
40	2.70	2.61	2.52	2.43	2.34	2.25
41	2.61	2.52	2.44	2.35	2.26	2.18
42	2.52	2.44	2.35	2.27	2.18	2.10
43	2.43	2.35	2.27	2.19	2.11	2.03
44	2.34	2.26	2.18	2.11	2.03	1.95
45	2.25	2.18	2.10	2.03	1.95	1.88
46	2.16	2.09	2.02	1.94	1.87	1.80
47	2.07	2.00	1.93	1.86	1.79	1.73
48	1.98	1.91	1.85	1.78	1.72	1.65
49	1.89	1.83	1.76	1.70	1.64	1.58
50	1.80	1.74	1.68	1.62	1.56	1.50
51	1.73	1.67	1.62	1.56	1.50	1.44
52	1.67	1.61	1.56	1.50	1.44	1.39
53	1.61	1.55	1.50	1.45	1.39	1.34
54	1.55	1.50	1.45	1.40	1.34	1.29
55	1.50	1.45	1.40	1.35	1.30	1.25
56	1.45	1.40	1.35	1.31	1.26	1.21
57	1.41	1.36	1.31	1.27	1.22	1.17
58	1.36	1.32	1.27	1.23	1.18	1.14
59	1.32	1.28	1.24	1.19	1.15	1.10
60	1.29	1.24	1.20	1.16	1.11	1.07
61	1.25	1.21	1.17	1.13	1.08	1.04
62	1.22	1.18	1.14	1.09	1.05	1.01
63	1.18	1.14	1.11	1.07	1.03	0.99
64	1.15	1.12	1.08	1.04	1.00	0.96

From Piper, 1970

In the PLI method the maximum permissible pounds of fish per pond may be calculated by the following formula:

$$W_p = W_i \times V \times L \times R_{\Delta}$$

Where: W_p = lbs fish at length L per pond

W_i = lbs fish per ft³ per inch body length per cubic foot per water replacement per hour

V = cubic feet of rearing space

L = length of fish (in.) at the end of the growth period

R_{Δ} = water changes per hour, determined by $\frac{8 \times \text{gpm}}{V}$

In this study, the PLI was used to represent the pounds of fish per inch of body length which the pond would support. It was then a simple matter to multiply the starting and ending lengths by the PLI to determine the starting and ending pond loadings.

The central figure in the PLI method is the pounds of fish per cubic foot of rearing space per water turn-over per hour per inch of body length (W_i). This figure can be expressed as the Density Index (D.I.) divided by the water changes per hour (R_{Δ}). The D.I. concept, developed by Piper (1972), has as its basis the fact that fish have an upper limit of crowding above which growth will be negatively affected. The D.I. equals the lbs of fish per ft³ per inch of body length. The following D.I. values were derived empirically:

rainbow trout	0.5
cutthroat trout	0.3
chinook salmon	0.3
coho salmon	0.4

Thus, the W_i serves another useful function by allowing a hatcheryman to determine the amount of water needed to maintain fish at a specified density. For example, a system has a W_i of 0.170 (Table 15) and the fish have a D.I.

Table 15. Pounds of fish (W_i) per cubic foot of rearing space per inch of body length per water turn-over per hour*.

°F	Elevation (feet above MSL)				
	0	1000	2000	3000	4000
32	0.427	0.416	0.405	0.394	0.381
33	0.416	0.405	0.394	0.382	0.369
34	0.405	0.394	0.382	0.371	0.358
35	0.394	0.382	0.371	0.360	0.348
36	0.382	0.371	0.360	0.349	0.337
37	0.371	0.360	0.349	0.337	0.326
38	0.360	0.349	0.337	0.326	0.315
39	0.349	0.337	0.326	0.315	0.304
40	0.337	0.326	0.315	0.303	0.293
41	0.326	0.315	0.305	0.293	0.283
42	0.315	0.305	0.293	0.283	0.273
43	0.303	0.293	0.282	0.273	0.264
44	0.292	0.282	0.272	0.264	0.256
45	0.281	0.272	0.262	0.254	0.244
46	0.270	0.261	0.252	0.242	0.234
47	0.259	0.250	0.241	0.232	0.225
48	0.247	0.239	0.231	0.222	0.215
49	0.236	0.229	0.220	0.212	0.205
50	0.225	0.217	0.210	0.202	0.195
51	0.216	0.209	0.202	0.195	0.188
52	0.209	0.201	0.195	0.187	0.180
53	0.201	0.194	0.187	0.181	0.174
54	0.194	0.187	0.181	0.175	0.168
55	0.187	0.181	0.175	0.168	0.163
56	0.181	0.175	0.168	0.164	0.158
57	0.176	0.170	0.164	0.159	0.153
58	0.170	0.165	0.159	0.154	0.148
59	0.165	0.160	0.155	0.148	0.144
60	0.161	0.155	0.150	0.145	0.139

* Applicable to raceways only

of 0.4, then the water changes per hour must exceed 2.35.

In using the PLI method it must be kept in mind that the pond is not loaded at that level. The initial loading must be back-calculated from the PLI load taking into account growth rate. This is inherent in both the BROCK and IRV programs.

B. Study Approach

The test systems consisted of two 8-tank units arranged so that there were duplicates of two fish sizes, two water replacement levels, two densities and two growth rates (Table 16). All groups were fed the same diet. The OWRT program was used to predict feeding rates and maximum loading.

C. Results and Discussion

The data obtained after four 14-day growth periods indicate that growth, measured as a change in length, was somewhat retarded in the $W_i = 0.154$ groups and markedly retarded in the $W_i = 0.385$ groups when compared with the $W_i = 0.062$ groups (Table 17). The difference between the mean growths of the two $W_i = 0.154$ groups is explained by the fact that the 1.3 water turn-over groups had hyperplastic gill epithelia and reduced oxygen uptakes. Presumably this was due to the accumulation of waste products. The gill tissues in the 3.25 water turn-over groups were unaffected and the oxygen uptakes were within prescribed limits (cf Section VI).

It was assumed from the data (Table 18) that if $W_i = 0.062$ can be considered to permit the maximum (100%) growth without the constraints of either density or water turn-over and that at $W_i = 0.154$ growth is affected by both density and water turn-over, the highest W_i at which growth is not affected by density or water turn-over lies somewhere between 0.062 and 0.154.

Table 16. Program inputs to test effects of density and water replacement on growth.

System	A'		A	
Water flow (gpm)	0.609	1.523	0.609	1.523
Density (lb/ft ³ /in.)	0.2	0.5	0.2	0.5
Fish L ₀ (in.)	1.305	1.305	2.866	2.866
ΔL (in./day)	0.045	0.045	0.035	0.035
Diet efficiency (%)	83.3	83.3	66.7	66.7

Common to all Systems

Elevation	3000' above MSL
Water temperature	59° F (15° C)
Volume	3.75 ft. ³
D.O. (in)	8.9 mg/l
D.O. (out)	6.0 mg/l
K-factor	4.0 x 10 ⁻⁴

Table 17. Growth (ΔL_t) of rainbow trout raised at two densities and at two water replacement times.

	A'-1	A'-2	A'-3	A'-4	A'-5	A'-6	A'-7	A'-8
D.I. (lb/ft. ³ /in.)	0.2	0.2	0.5	0.5	0.2	0.2	0.5	0.5
R_{Δ} (Water replacements per hour)	3.25	1.3	3.25	1.3	3.25	1.3	3.25	1.3
Initial Length (L_0)	1.305	1.305	1.305	1.305	1.305	1.305	1.305	1.305
Growth Period (14 days)								
1	1.746	1.726	1.732	1.742	1.742	1.756	1.711	1.746
2	2.132	2.069	2.018	1.963	2.142	2.071	2.093	1.988
3	2.327	2.415	2.436	2.266	2.469	2.415	2.346	2.240
4	2.799	2.614	2.614	2.411	2.982	2.746	2.825	2.293
ΔL_t	1.494	1.327	1.309	1.106	1.677	1.441	1.502	0.988
$\frac{\Delta L_t}{L_0}$ (%)	114.5	101.7	100.3	84.8	128.5	110.4	116.5	75.7

Table 17. Continued.

	A-1	A-2	A-3	A-4	A-5	A-6	A-7	A-8
D.I. (lb/ft. ³ /in.)	0.2	0.2	0.5	0.5	0.2	0.2	0.5	0.5
R _Δ (Water replacements per hour)	3.25	1.3	3.25	1.3	3.25	1.3	3.25	1.3
Initial Length (L ₀)	2.866	2.866	2.866	2.866	2.866	2.866	2.866	2.866
Growth Period (14 days)								
1	3.059	3.089	3.071	2.933	3.240	3.175	3.079	2.980
2	3.364	3.382	3.287	3.112	3.510	3.344	3.258	3.157
3	3.876	3.628	3.719	3.163	3.945	3.880	3.732	3.266
4	3.982	3.821	3.913	3.293	4.343	4.167	4.152	3.423
ΔL _t	1.116	0.955	1.047	0.427	1.477	1.301	1.286	0.557
$\frac{\Delta L_t}{\Delta L_0}$ (%)	38.9	33.3	36.5	14.9	51.5	45.4	44.9	19.4

Table 13. Comparison of methods to estimate carrying capacity in systems having the constraints or density and water replacement.

	Period 1 - A' System			
	1	2	3	4
Water changes/hr (R)	3.25	1.3	3.25	1.3
lb/ft ³ /in. (D.I.)	0.2	0.2	0.5	0.5
$W_i \left(\frac{D.I.}{R} \right)$	0.062	0.154	0.154	0.385
Carrying capacity (lb) (PLI Method)	1.4	1.5	3.6	3.6
Est. growth (in.)	2.52	2.52	2.52	2.52
Obs. growth (in.)	1.58	1.37	1.42	0.99
Obs./est. (%)	62.7	54.4	56.3	39.3
Calculated carrying capacity (lb) per:				
Feed Level Method	2.1	0.8	2.1	0.8
Flow Index Method	3.4	1.4	3.4	1.4
Oxygen Uptake Method	4.0	1.6	4.0	1.6
Density Factor Method	1.4	1.4	3.6	3.6
Water Replacement Time Method	1.5	0.6	1.5	0.6

Attempts to validate this assumption by accurately locating the W_i permitting maximum growth without being affected by either density or water turn-over failed because of the insufficient number of data points to establish a meaningful slope. However, by comparing the data from all groups tested in this study, for whatever intent, a W_i of 0.144 appeared consistently to be the value sought. The W_i from the table (Table 15) is 0.148, or 2.8% over the W_i suggested by the data.

For comparison with other methods of determining permissible biomass in the study systems, the inputs for the first growth period in system A' (Table 16) were used. Assuming that the PLI method is valid, all methods can be used safely. However, if density is a constraint the biomass permitted using either Flow Index method or the Oxygen Uptake method will require correction as neither considers density. Also, if water turn-over is a constraint the biomass permitted using the Density Factor method will have to be corrected because it does not consider water inflow. Use of either the Feed Level method or the Water Replacement Time method will permit safe loadings, though considerably under optimum, in the systems tested.

In summary, the PLI method offers the user the ability to consider fish length, water inflow, and density in raceway systems. The table W_i is the relationship between density and water replacements per hour. If density is a constraint, then the water flow can be adjusted and vice versa. For example, the table $W_i = 0.165$, the optimum Density Index is 0.3, then the water replacements must exceed 1.82 per hour. Correspondingly, if only 1.4 water replacements per hour are available, the density cannot exceed $0.23 \text{ lb/ft}^3/\text{in.}$ without growth being affected.

References Cited

- Piper, R.G. (1970): Know the proper carrying capacities of your farm. American Fishes and U.S. Trout News 15(1):4.
- Piper, Robert G. (1972): Managing hatcheries by the numbers. Amer. Fishes and U.S. Trout News. 17(3):10.
- Westers, H. (1970): Carrying capacity of salmonid hatcheries. Prog. Fish-Cult. 32(1):43.

IX. ESTIMATION OF SOLIDS GENERATED IN AN AQUACULTURE SYSTEM: A STUDY

A. Background

As was stated at the outset of this report, the discharge of waste products from aquaculture systems has come under the scrutiny of the Environmental Protection Agency. At the present time the average suspended solids load which can be discharged legally is 2.2 pounds per 100 pounds of fish per day. The maximum daily suspended solids load cannot exceed 3.3 pounds per 100 pounds of fish. The cleaning effluent shall not contain more than 2.2 ml/l settleable solids and the non-cleaning effluent shall not contain more than 0.2 ml/l settleable solids. Currently, large amounts of money and time are being spent in both the public and private sectors to seek economic and practical methods of compliance with the existing regulations. This study is part of those efforts.

This portion of the study was developed from the belief that management methods were sufficient to maintain discharge quality within the regulated levels. Considerable time was spent identifying the qualitative and quantitative factors involved in waste product generation (cf Section III).

Throughout the process of factor identification, feed quality and quantity kept emerging as the most likely candidate for study. The feed quantity was considered to be dependent upon the desired growth rate and the dietary efficiency; i.e., feed quality. It was further considered that the hatcheryman had the ability to establish the growth rate within the constraints of the aquaculture system; however, he had no control over the dietary quality unless a diet of specified composition were fed.

There have been two methods of estimating the amount of solids generated daily in an aquaculture system. Both are based upon the feeding rate (lbs of feed per 100 lbs of fish) and do not take into account dietary efficiency. Willoughby et al. (1972) proposed that by multiplying the pounds of feed fed per gpm by 25, one could estimate the mg/l solids generated. Converting mg/l to pounds per day can be accomplished in the following manner:

$$\text{lbs} = \frac{\text{mg/l} \times \text{cfs}}{0.184}$$

Thus, the calculation then becomes:

$$\text{lbs. solids per day} = \frac{25 \times \text{lbs feed/gpm} \times \text{cfs}}{0.184}$$

Liao (1974) proposed that the suspended solids production rate (lbs/100 lbs fish/day) at 50-58F could be estimated by multiplying the feed rate (lbs feed/100 lbs fish/day) by 0.52.

In this study, a new method of estimating pounds of solids generated per 100 pounds of fish per day which considered both dietary quality and quantity was tested.

B. Study Approach

Data were gathered from applying methods described in Sections V, VI, VII, and VIII. In each of these sections were provisions for determining feed efficiencies as they related to estimated growth rates. Daily solids production levels were recorded for varying conditions of population density, water replacement time, feeding rate, and diet quality.

C. Results and Discussion

It became apparent at the outset of data analyses that dietary efficiency was not only a function of diet quality but of feeding rate based upon estimated weight gain. The method used to estimate weight gain was based upon the ΔL

concept in which the daily increase in length is proportional to the cube root of the weight. Thus, if a group of fish of 3 in. (uniform length) were to increase their length by 0.5 in., the expected weight gain would be 58.7% of the starting weight. For a group of 5 in. fish, an increase of 0.5 in. would increase the weight by 32.9% of the starting weight. These estimations (Table 19) were taken from the weight-length tables (USFWS 1977) and are independent of K-factor.

Data from four lots of fish were selected (Table 20) to typify the situation. Lot A'-6-3 was fed to achieve a weight gain of 111.8%, and Lot A'-2-3 was fed for a 81.5% weight gain. Both groups contained virtually the same length of fish with a length range of 20 mm. The weight gain during the 14-day period was 55.7% and 51.5% respectively. It should be noted that the fish in both groups ate all the feed with little or no wastage. A third group Lot S-B11-4 consisting of similar sized fish but in greater numbers was fed for a 68.1% weight gain and the actual gain was 51.6%. The maximum weight gains considered possible, based upon % length increase under the circumstances, were 56.4%, 56.8%, and 53.4% respectively. A fourth group (Lot L-B12-4) consisting of large fish (4") were fed for a 43.6% weight gain and the actual gain was 43.5% with the maximum gain for this sized fish estimated to be 47.2%.

The following dietary efficiencies were recorded for the four groups:

<u>% est. weight gain</u>	<u>% diet efficiency</u>	<u>conversion</u>
111.8	40.1	1:2.49
81.5	50.8	1:1.97
68.1	55.9	1:1.79
43.6	64.5	1:1.55

Table 19.

% WEIGHT INCREASE (% Δ W) IN
RELATION TO LENGTH INCREASE (Δ L)

<u>Length (in.)</u>	<u>% W/0.25" ΔL</u>	<u>% W/0.5" ΔL</u>
1.0		
1.25	95.4	
1.5	73.1	238.2
1.75	58.4	
2.0	49.3	136.6
2.25	42.5	
2.5	37.1	95.3
2.75	33.8	
3.0	29.1	72.8
3.25	27.1	
3.5	24.8	58.7
3.75	23.1	
4.0	21.4	49.4
4.25	20.2	
4.5	18.9	42.9
4.75	17.4	
5.0	16.5	36.7
5.25	15.7	
5.5	14.9	32.9
5.75	14.2	
6.0	13.6	29.9
6.25	13.1	
6.5	12.6	27.3
6.75	11.9	
7.0	11.5	24.4
7.25	11.2	
7.5	10.9	23.6
7.75	10.5	
8.0	9.6	22.0
8.25	9.6	
8.5	9.3	19.8
8.75	9.1	
9.0	8.9	18.7
9.25	8.7	
9.5	8.5	18.1
9.75	7.9	
10.00	7.8	16.3

Table 20. Growth in four groups of rainbow trout fed at different rates based on estimated weight gain.

Lot	A'-6-3	A'-2-3	L-B12-4	S-B11-4
Diet	A-4	A-4	B-5	B-3
% ΔW_{14} - expected	111.8	81.5	43.6	68.1
% ΔW_{14} - observed	55.7	51.5	43.5	51.6
*Max % ΔW_{14}	56.4	56.8	47.2	53.4
Length (in.) - start	2.071	2.069	4.059	2.733
Length (in.) - end	2.415	2.415	4.623	3.162
ΔL_{14} (in.) - observed	0.344	0.346	0.564	0.429
ΔL_{14} (in.) - expected	0.63	0.49	0.56	0.56
% ΔL_{14} - observed	16.1	16.7	13.9	15.7
% ΔL_{14} - expected	23.7	30.4	13.8	20.5
% Digestibility				
Total	50.8	40.1	55.9	64.5
Protein	73.3	52.4	68.4	84.1
CEL	55.9	31.1	31.1	88.8
NFE	30.1	41.7	54.2	56.9
PER	0.97	0.77	1.11	1.36
TDN	65.1	55.9	67.5	77.7

Thus, it can be seen that although the three groups of fish in the 2" size range were fed at different levels, all three grew about the same with the differences being seen in the diet efficiencies. This indicates that there were more waste products generated in the 111.8% weight gain group as compared with the 43.6% weight gain group.

By comparing proximate analyses of the collected feces with the proximate analyses of the diets, another facet of growth becomes apparent (Table 20). The protein utilization was highest in group Lot L-B12-4 and lowest in Lot A'-6-3; i.e., the lowest and highest estimated percent weight gain, respectively. These are substantiated by the PER (Protein Efficiency Ratio) values. However, fat utilization among all groups, irregardless of feeding rate, was very similar. Carbohydrate utilization (expressed as NFE digestibility) varied apparently independent of feeding rate. Among the several explanations for these observations, the only one lending itself to being plausible is: The high feeding rate fish (111.8% weight gain) were fed several times daily and the sheer bulk as compared to a lower feeding rate group decreased the time the ingesta resided in the digestive tract. Also, the intestinal tract was much more distended in the higher feeding rate group than in the lower feeding rate group, thereby decreasing the exposure of the ingesta to the intestinal lining. Both these factors contributed to the decreased over-all efficiency. Apparently, fat is absorbed quite readily while it takes more time and less intestinal distension to utilize crude protein efficiently. These assumptions are somewhat born out in the TDN values.

From the foregoing observations and interpretations, it became obvious that a better method of estimating the weight gain during a growth period must be developed. It is accepted that small fish have a greater percent weight gain per length increment increase than do larger fish. This can be easily visualized by comparing the weight/1000 fish gain with length

increase using the standard length-weight tables. For example, fish under 1.5" will increase in weight 4.7% for each percent length increase while fish over 5.5" will increase their weight 3.4% for each percent length increase (Table 21).

Table 21. To calculate estimated % weight gain multiply the % estimated length increase by the approximate W-factor.

<u>Fish length</u>	<u>W-factor</u>
<1.5"	4.7
1.5 - 5.5	3.8
3.0 - 5.5	3.4
5.5 - 10	3.2

For example, a 14-day length increase expected for 4.2" fish is 0.4" or a 9.5% increase. The estimated weight increase will be 9.5 x 3.4 or 32.3%. Using the ΔL method, only a 28.6% weigh increase can be expected for the same period. This suggests that the length-weight conversion factor of 3 in the ΔL equation should be replaced with the correct "W-factor". In the example, the two methods would be equilibrated if this were done, thus negating the necessity of having to calculate the % length increase and multiplying it by the "W-factor". Back-calculating this concept into the data presented (Table 20) indicates a high degree of correlation.

Applying these assumptions together with the weights of feces collected for each group, gave rise to a method of estimating the solids generated per 100 pounds (S_{100}) of fish per day. It states:

$$S_{100} = 0.95 [\text{lbs fed} - (\text{lbs fed} \times \text{efficiency})] \times \text{cwt}$$

It assumes that 95% of the metabolic waste will be as solids. This assumption is supported by the fecal sample data. Recalling that the feces were collected

in fine mesh "socks", dried and weighed, an error in quantitative proximate analysis could have been introduced by the leaching of the solubles into the water. However, the leaching was considered to be of no consequence because this is what normally happens to fish feces.

The method has the advantage over the Willoughby method and the Liao method by considering the dietary efficiency. In two selected groups of fish (Table 21), the following lbs of solids per 100 lbs of fish were calculated:

Lot L-A12-4-14 (the 14 day of the 4th period of Lot L-A-12)

Willoughby - 1.06

Liao - 2.24

Proposed - 2.34

Lot L-B12-4-14 (the 14th day of the 4th period of Lot L-B12)

Willoughby - 1.32

Liao - 2.38

Proposed - 1.55

(From Table 22)

Both groups consisted of essentially the same number of fish and the same size fish. Both were fed at comparable rates. The difference was in the respective dietary efficiencies. Lot L-A12 had a dietary efficiency of 41.3% whereas, lot L-B12 had a dietary efficiency of 64.1%. According to the Liao method both groups exceeded the EPA discharge limits and according to the Willoughby method neither exceed the EPA discharge limits. However, according to the proposed method the lot with the lower dietary efficiency exceed the discharge limits but the other did not.

A chart was constructed to estimate the pounds of solids generated per 100 pounds of feed based upon the dietary efficiency (Table 23). It is very simple to visualize the importance of having the dietary efficiency as

Table 22. Estimation of solids (lb) produced daily in two groups of rainbow trout using three methods.

Example 1:

Unit - L-A12-4-14

Biomass - 49.6 lb (22.518 kg)

Feed - 2.08 lb (944.32 g)

Feeding Rate - 4.3%

Dietary Efficiency - 0.413

Water - 28.1 gpm (0.0624 cfs)

Willoughby's Method:

$$\text{Solids} = \frac{25 \times \text{lb feed/gpm} \times \text{cfs}}{0.184}$$

$$= 0.593 \text{ lb}$$

$$= 1.106 \text{ lb/100 lb fish}$$

Liao's Method:

$$\text{Solids} = 0.52 \times \text{feed rate} \times \text{lb fish} \times 10^{-2}$$

$$= 1.11 \text{ lb}$$

$$= 2.24 \text{ lb/100 lb fish}$$

Proposed Method:

$$\text{Solids} = 0.95 [\text{lbs feed} - (\text{lbs fed} \times \text{effic.})]$$

$$= 1.16 \text{ lb}$$

$$= 2.34 \text{ lb/100 lb fish}$$

Table 22. Continued.

Example 2:

Unit - L-B 12-4-14

Biomass - 52.86 lb (23.998 kg)

Feed - 2.42 lb (1.098 kg)

Feeding rate - 4.58%

Dietary Efficiency - 0.641

Water - 17.97 gpm (0.0399 cfs)

Willoughby's Method:

$$\text{Solids} = \frac{25 \times \text{lb feed/gpm} \times \text{cfs}}{0.184}$$

$$= 0.70 \text{ lb}$$

$$= 1.32 \text{ lb/100 lb fish}$$

Liao's Method:

$$\text{Solids} = 0.52 \times \text{feed rate} \times \text{lb fish} \times 10^{-2}$$

$$= 1.26 \text{ lb}$$

$$= 2.38 \text{ lb/100 lb fish}$$

Proposed Method:

$$\text{Solids} = 0.95 [\text{lbs feed} - (\text{lbs fed} \times \text{effic.})]$$

$$= 0.82 \text{ lb}$$

$$= 1.55 \text{ lb/100 lb fish}$$

Table 23. Estimated* lbs solids/100 lb feed as related to dietary efficiency.

Feed conversion	Dietary efficiency (%)	<u>Lbs solids</u> <u>100 lb feed</u>
1.1	90.9	8.65
1.2	83.3	15.87
1.3	76.9	21.95
1.4	71.4	27.17
1.5	66.7	31.64
1.6	62.5	35.63
1.7	58.8	39.14
1.8	55.6	42.18
1.9	52.6	45.03
2.0	50.0	47.50
2.1	47.6	49.78
2.2	45.5	51.78
2.3	43.5	53.68
2.4	41.7	55.39
2.5	40.0	57.00

* Solids (lbs) = 0.95 [lbs fed - (lbs fed x diet effic.)]

high as possible. For example, 300 lbs of feed being fed daily to 10,000 pounds of fish will generate 1.07 lbs solids per 100 lbs of fish at a dietary efficiency of 62.5%. However, at a dietary efficiency of 50%, 1.43 lbs of solids per 100 lbs of fish will be generated.

In summary, we think that more basic and applied research must be done to "fine tune" the method used. At best estimate, based upon the data collected, there is no more than a 5% error between the actual values and the calculated values. Furthermore, we think a large portion of the error to consist of the usual rounding errors encountered whenever numerical significance is attempted.

References Cited

- Anon. (1977): Manual of Fish Culture. Appendices 1.5-5.0 - English and metric length-weight relationships for fish. U.S. Fish and Wildlife Service, USDI.
- Liao, P.B. and R.D. Mayo (1974): Intensified fish culture combining water reconditioning with pollution abatement. *Aquaculture* 3:61.
- Willoughby, Harvey, Howard N. Larsen, and J.T. Bowen (1972): The pollutional effects of fish hatcheries. *Amer. Fishes and U.S. Trout News*. 17(3):6.

X. SUMMARY

As was stated at the outset of this report, the objectives of this study were to develop and test methods of predicting waste product generation from aquaculture facilities. The approach to attain the objectives began with a complete identification of the factors involved in waste product generation. It was found that, among the 40-plus factors having the capability of affecting production in an aquaculture facility, each factor interacted with one or more factors in a dependent or counterdependent manner. The problem of selecting those factors having the greatest role in waste product generation and also having the greatest potential of being controlled through management techniques was resolved after considerable consultation with professional fish culturists - both public and private - and testing opinions in a model flow chart.

The factors chosen for testing were: 1) feeding rate; 2) diet efficiency; 3) growth rate; 4) population density; 5) water replacement time; 6) oxygen consumption; 7) fish size; 8) water temperature. Although there were other probable choices for consideration; we believed the eight chosen were at "the top of the heap" with the other factors being dependent functions of them (cf Section II).

We believe the following to be significant findings resulting from the study:

- 1) The identification of factors involved not only with the generation of waste products from an aquaculture facility; but the identification of factors having the potential of affecting the production of an aquaculture facility.

- 2) The development of a practical method for determining oxygen consumption of fish in varying (controlled) environmental conditions.
- 3) The development of a computerized program for fish growth in optimized loading conditions of population density and water replacement time.
- 4) A method to predict more accurately the anticipated growth rate of a group of fish which corrects the existing method.
- 5) A method to predict the solids - both settleable and suspended - produced daily by a group of fish being held in known conditions.

Although it is conceded that more research must be done, this study clearly indicates that it is within the capability of existing fish culture technology to control waste product discharge from fish raising facilities through management so as to comply with the current EPA regulations. The need for sophisticated and expensive pond cleaning equipment and solids disposal should be necessary only in those cases where continuously cleaning ponds do not exist or cannot be modified to be so.

In conclusion, we would like to suggest the following for future research areas to further understand the fish:water:nutrition:container:management interrelationships:

- 1) The effect of dietary quality on survival of game fish following release from the hatchery environment.
- 2) The testing of the fish:container relationships with respect to hydraulic action of the pond, fish behavior, self-cleaning propensities, and pond shape and dimensions.
- 3) The effect of regularly scheduled continuing education sessions for fish culturists and fishery resource managers.

APPENDIX I

Published Carrying Capacity Methods

A. Feeding Level Method (Haskell 1955)

$$\text{Lbs. fish/cu.ft.} = \frac{\text{max. lbs. feed per cu.ft.} \times 100}{\text{percent body weight fed}}$$

B. Feeding Level Method (Willoughby 1968)

$$W_n = \frac{N}{R_f \times 10^{-2}}$$

Where: W_n = total weight of fish in pond (lbs)

N = pounds of food per day

$$= (O_a - O_b) \times \frac{5.45}{100} \times R_w$$

O_a = ppm dissolved oxygen incoming

O_b = ppm dissolved oxygen at outfall (min. 5 ppm for salmonids)

5.45 = metric tons of water at 1 gpm for 24 hours

100 = grams oxygen required to metabolize 1200 kcal

R_w = water inflow in gpm

R_f = feeding rate in percent body weight of fish

$$= \frac{\text{conversion} \times \Delta L \times 3 \times 100}{L}$$

conversion = pounds of feed required per pound of body weight gain

ΔL = daily increment of length increase (hr)

3 = weight-length conversion factor

C. Water Replacement Time Method (Westers 1970)

$$\text{Lb fish/cu.ft.} = \frac{\text{lb. fish/gpm} \times \text{no. water changes/hour}}{8}$$

$$Wt = \frac{(W_{\text{gpm}} \times R\Delta) \times V}{8}$$

Where Wt = pounds of fish in pond

W_{gpm} = pounds of fish/gpm

$R\Delta$ = water changes/hour

8 = conversion of gpm to cfh

V = pond volume (cu.ft.)

D. Oxygen Uptake Method (Elliott 1969)

$$W = \frac{O_i - O_o}{Y_n}$$

Where: W = pounds of fish per gpm

Y = oxygen requirement for fish at size 'n'.

= $a \times T - b$

(a & b are constants, T is $^{\circ}F$)

F. Oxygen Consumption Method (Liao 1971)

$$W_o = \frac{R_w \times 1.2 (C_e - C)}{K \times T^n \times W^m}$$

Where: W_o = weight of fish in pond (lbs)

R_w = water inflow (gpm)

1.2 = correction constant

C_e = dissolved oxygen (ppm) at temperature (T in ° F)
elevation (E) and saturation (S)

$$= \frac{S \times 132}{T^{0.625}} \times \frac{760}{760 + E} \times \frac{1}{32.8}$$

C = minimum dissolved oxygen at outfall

K = rate constants

salmon	<50° F	7.20×10^{-7}
	>50° F	4.90×10^{-5}
	<50° F	1.90×10^{-6}
	>50° F	3.05×10^{-4}

T = water temperature (° F)

n = temperature-water slope

salmon	<50° F	3.200
	>50° F	2.120
trout	<50° F	3.130
	>50° F	1.855

W = weight of individual fish (lb)

m = weight-oxygen slope

<50° F	-0.194
>50° F	-0.194
<50° F	-0.138
>50° F	-0.138

G. Density Factor Method (Piper 1972)

$$Wd = D \times V \times L$$

Where: Wd = total weight of fish in pond (lbs)
 D = density factor (lbs fish/cu.ft./in. fish length)
 V = volume of rearing space in pond (cu.ft.)
 L = length of fish (in.)

Table 1. Load factors (lbs fish/inch of length/gpm) for trout and salmon as related to water temperature and elevation.

Water Temperature F ^o	0	1000	2000	3000	4000	5000
40	2.70	2.61	2.52	2.43	2.34	2.25
41	2.61	2.52	2.44	2.35	2.26	2.18
42	2.52	2.44	2.35	2.27	2.18	2.10
43	2.43	2.35	2.27	2.19	2.11	2.03
44	2.34	2.26	2.18	2.11	2.03	1.95
45	2.25	2.18	2.10	2.03	1.95	1.88
46	2.16	2.09	2.02	1.93	1.87	1.80
47	2.07	2.00	1.93	1.86	1.79	1.73
48	1.98	1.91	1.85	1.78	1.72	1.65
49	1.89	1.83	1.76	1.70	1.64	1.58
50	1.80	1.74	1.68	1.62	1.56	1.50
51	1.73	1.67	1.62	1.56	1.50	1.44
52	1.67	1.61	1.56	1.50	1.44	1.39
53	1.61	1.55	1.50	1.45	1.39	1.34
54	1.55	1.50	1.45	1.40	1.34	1.29
55	1.50	1.45	1.40	1.35	1.30	1.25
56	1.45	1.40	1.35	1.31	1.26	1.21
57	1.41	1.36	1.31	1.27	1.22	1.17
58	1.36	1.32	1.27	1.23	1.18	1.14
59	1.32	1.28	1.24	1.19	1.15	1.10
60	1.29	1.24	1.20	1.16	1.11	1.07
61	1.25	1.21	1.17	1.13	1.08	1.04
62	1.22	1.18	1.14	1.09	1.05	1.01
63	1.18	1.14	1.11	1.07	1.03	0.99
64	1.15	1.12	1.08	1.04	1.00	0.96

APPENDIX II

List of OWRT Fish Culture Program

OWRT

```

10 WRITE(6,10)
20 10 FORMAT(3X,'TYPE IN THE NUMBER OF TANKS AND NO. OF PERIODS TO BE RUN -
EXAMPLE ?3,1')
30 READ(5,*)JJ,MM
40 DO 123 J=1,JJ
50 WRITE(6,1)
60 1 FORMAT(3X,'TYPE IN ROOM NUMBER AND TANK NUMBER (8 SPACES MUST BE FILLED)
EX. ?112, 5A')
70 READ(5,23)A,AA
80 23 FORMAT(2A4)
90 WRITE(6,33)
100 33 FORMAT(2X,'TYPE IN DELTAL,MAX. DENSITY INDEX,POND CHANGES(RDELTA),PLI
NO.,% DAILY MORTALITY')
110 READ(5,*)DELTAL,DI,RDELTA,PLIALT,PCMORT
120 WRITE(6,25)
131 25 FORMAT(1X,'TPE IN LENGTH,NO./LB.,K-FACTOR,POND VOLUME,EST. CONVERSION,
WATER TEMP.')
```

$$ZLONG = ZLONG + DELTAL * 13$$

$$ZMDI = DI * VOL * ZLONG$$

$$ANOLB = 1. / (ZKFACT * ZLONG ** 3)$$

$$ZNUMB = ZMDI * ZNOLB / ((1. - PCMORT / 100.) ** 13)$$

$$DAY14 = (ZNUMB / ZNOLB) * (ESTCON * 3 * DELTAL) / ZLONG$$

$$ZLONG = ZLONG - DELTAL * 13.$$

$$FEDSUM = 0.$$

$$XDAY14 = .05 * DAY14 * 454$$

$$XDAY14 = .093 * DAY14 * 454$$

$$AMDI = DI * VOL * ZLONG$$

$$ZNOLB = 1. / (ZKFACT * ZLONG ** 3)$$

$$MORTS = ZNUMB * (PCMORT / 100.)$$

$$TOTWT = ZNUMB / ZNOLB$$

```

140 READ(5,*)ZLONG,ZN(LB,ZKFACT,VOL,ESTCON,TEMP)
150 WRITE(6,26)A,AA
160 26 FORMAT(20X,'ROOM NUMBER",A4,3X,'TANK NUMBER',A4)
170 WRITE(6,2)DELTAL,TEMP
180 2 FORMAT(1X,' DELTAL = ',F6.4,30X,' TEMPERATURE = ',F5.0/)
190 WRITE(6,3)ESTCON,RDELTA
200 3 FORMAT(1X,'EST. CONVERSION = ',F5.3,27X,'POND CHANGES/HOUR = ',F5.3/)
210 WRITE(6,4)ZLONG,ZNOLB
220 4 FORMAT(1X,'STARTING FISH LENGTH = ',F6.4,21X,'#/LB - ',F10.3/)
230 WRITE(6,6)VOL,DI
240 6 FORMAT(1X,'POND VOLUME = ',F9.3,30X,'DENSITY INDEX = ',F5.3/)
242 WRITE(6,7)ZKFACT,PCMORT
244 7 FORMAT(1X,'K-FACTOR = ',F8.6,30X,' % DAILY MORTALITY - ',F5.3/)
250 DO 180 M=1,MM
260 WRITE(6,11)
270 11 FORMAT(1X,/' DAY POND WEIGHT NO.?LB LENGTH % BW FED FEED NO. FISH')
280 ZLONG=ZLONG+DELTAL*13
290 ZMDI=DI*VOL*ZLONG
300 ANOLB=1./(ZKFACT*ZLONG**3)
310 ZNUMB=ZMDI*ZNOLB/((1.-PCMORT/100.)**13)
315 DAY14=(ZNUMB/ZNOLB)*(ESTCON*3*DELTAL)/ZLONG
320 ZLONG=ZLONG-DELTAL*13.
330 FEDSUM=0.
340 DO 111 I=1,14
342 IF(I .GT. 7) GO TO 99
344 XDAY14=.05*DAY14*454
345 GO TO 17
346 99 XDAY14=.093*DAY14*454
348 17 CONTINUE
350 AMDI=DI*VOL*ZLONG
360 ZNOLB=1./(ZKFACT*ZLONG**3)
380 MORTS=ZNUMB*(PCMORT/100.)
390 TOTWT=ZNUMB/ZNOLB
```

```
400 PLI=PLIALT*VOL*ZLONG*RDELTA
410 PCBDWT=(ESTCON*300.*DELTAL)/ZLONG
420 FOODFD=(TOTWT*PCBDWT/100.)*454.+XDAY14
425 IF(I .EQ. 14) FOODFD=0.
430 FEDSUM=FEDSUM+FOODFD
440 IF(M .EQ. 1) GO TO 100
450 IF(I .NE. 1) GO TO 100
460 DIFFWT=ZMMDI-TOTWT
470 DIFNUM=ZNNUMB-ZNUMB
480 WRITE(6,5)DIFFWT,DIFNUM
490 5 FORMAT(1X,'REMOVE ',F10.3,'POUNDS OR ',F10.0,'FISH'/)
501 100 WRITE(6,15)I,TOTWT,ZNOLB,ZLONG,PCBDWT,FOODFD,ZNUMB
510 15 FORMAT(I5,F12.2,F8.2,3F10.2,F10.0,/)
520 ZLONG=ZLONG+DELTAL
530 ZNUMB=ZNUMB-MORTS
540 ZMMDI=ZMDI
550 ZNNUMB=ZNUMB+MORTS
560 111 CONTINUE
565 WRITE(6,112) FEDSUM
566 112 FORMAT(1X,' TOTAL FEED FOR PERIOD = ',F12.2,'GRAMS'/)
570 180 CONTINUE
580 123 CONTINUE
590 STOP
600 END
```

APPENDIX III

List of BROCK Fish Culture Program

BROCK

```

10 WRITE(6,20)
20 20 FORMAT(3X,'TYPE IN THE POND LOADING FORMULA YOU WISH TO USE---TYPE
IN 1 FOR WILLOUGHBY; 2 FOR WESTERS; 3 FOR LIAO; 4 FOR PIPER DENSITY INDEX
METHOD; 5 FOR PIPER FLOW INDEX METHOD; and 6 FOR KLONTZ')
30 READ(5,*)LL
40 IF(LL.EQ.1) GO TO 126
50 IF(LL .EQ. 2) GO TO 71
60 IF(LL .EQ. 3) GO TO 157
70 IF(LL .EQ. 4) GO TO 43
80 IF(LL.EQ.5) GO TO 98
90 WRITE(6,21)
100 21 FORMAT(3X,'YOU HAVE CHOSEN THE KLONTZ LOADING FORMULA--TYPE IN THE
NUMBER OF PONDS TO BE LOADED--EXAMPLE ++? 5')
110 READ(5,*)NPL
120 DO 1 J-1,NPL
130 WRITE(6,22)
140 22 FORMAT(3X,'TYPE IN POND NUMBER AND HOW MANY DAYS THE PERIOD IS TO RUN----
EXAMPLE? 10,14')
150 READ(5,*)NP,ND
160 WRITE(6,23)
170 23 FORMAT(3X,'TYPE IN DELTA L, FISH LENGTH, K-FACTOR, ESTIMATED CONVERSION')
180 READ(5,*)DELTAL,ZLONG,ZKFACT,ESTCON
190 WRITE(6,24)
200 24 FORMAT(3X,'TYPE IN POND VOLUME,POND CHANGES/HOUR,PLI NUMBER,% DAILY MOR
TALITY. ')
210 READ (5,*)VOL,RDELTA,PLI,PCMORT
220 WRITE(6,25)NP
230 25 FORMAT(20X,'KLONTZ LOADING METHOD FOR POND ',I2/)
240 WRITE(6,26)ZLONG,ZKFACT
250 26 FORMAT(3X,'STARTING FISH LENGTH = ',F7.4,T45,'K-FACTOR = ',F7.6/)
260 WRITE(6,27)DELTAL,ESTCON
270 27 FORMAT(3X,'DELTA L - 1,F6.4,T45,'ESTIMATED CONVERSION = ',F5.3/)
280 WRITE(6,28)VOL,PCMORT
290 28 FORMAT(3X,'POND VOLUME = ',F9.2,T45,'% DAILY MORTALITY = ',F5.3/)
300 WRITE(6,29)PLI,RDELTA
310 29 FORMAT(3X,'PLI NUMBER = ',F4.3,T45,'POND CHANGES/HOUR = ',F5.3/)
340 WRITE(6,30)
350 30 FORMAT(3X,'DAY POND WT. NO/LB LENGTH % BW FED FEED No. Fish'/)
360 ZLONG=ZLONG+DELTAL*(FLOAT(ND)-1.)
370 ZNOLB=1./(ZKFACT*ZLONG**3)
380 ZPLI=VOL*RDELTA*ZLONG*PLI
390 ZNUMB=ZPLI*ZNOLB/((1.-PCMORT/100.))**(FLOAT(ND)-1.)
400 ZLONG=ZLONG-DELTAL*(FLOAT(ND)-1.)
410 FEDSUM=0.
420 ZGPM=VOL*RDELTA*7.5/60.
430 CALL FISH(FEDSUM,ZKFACT,ZLONG,ZNUMB,ESTCON,DELTAL,PCMORT,ND,ZGPM)
440 1 CONTINUE
450 GO TO 75
460 43 WRITE(6,31)
470 31 FORMAT(3X,'YOU HAVE CHOSEN THE PIPER DENSITY INDEX METHOD---TYPE IN
THE NUMBER OF PONDS TO BE LOADED---EXAMPLE ? 5')
490 READ(5,*)NPL

```

```

500 DO 2 J=1,NPL
510 WRITE (6,22)
520 READ(5,*)NP,ND
530 WRITE(6,23)
540 READ(5,*)DELTAL,ZLONG,ZKFACT,ESTCON
550 WRITE(6,32)
560 32 FORMAT(3X,'TYPE IN POND VOLUME,WATER TEMPERATURE, MAXIMUM DENSITY
INDEX, % DAILY MORTALITY,POND TURNOVERS/HR')
570 READ(5,*)VOL,TEMP,DI,PCMORT,RDELTA
580 WRITE(6,33)NP
590 33 FORMAT(20X,'PIPER DENSITY INDEX METHOD FOR POND ',I2/)
600 WRITE (6,26) ZLONG,ZKFACT
610 WRITE (6,27) DELTAL,ESTCON
620 WRITE (6,34) DI,TEMP
630 34 FORMAT(3X,'MAXIMUM DENSITY INDEX = ',F4.3,T45,'WATER TEMPERATURE =
',F3.0/)
640 WRITE (6,28) VOL,PCMORT
660 WRITE (6,30)
670 ZLONG=ZLONG+DELTAL*(FLOAT(ND)-1.)
680 ZMDI=ZLONG*VOL*DI
690 ZNOLB=1./(ZKFACT*ZLONG**3)
700 ZNUMB=ZMDI*ZNOLB/((1.-PCMORT/100.))**(FLOAT(ND)-1.)
710 ZLONG+ZLONG-DELTAL*(FLOAT(ND)-1.)
720 FEDSUM=0.
730 ZGPM=VOL*RDELTA*7.5/60.
740 CALL FISH (FEDSUM,ZKFACT,ZLONG,ZNUMB,ESTCON,DELTAL,PCMORT,ND,ZGPM)
750 2 CONTINUE
760 GO TO 75
770 71 WRITE (6,99)
780 99 FORMAT(3X,'YOU HAVE CHOSEN THE WESTERS LOADING FORMULA---TYPE IN THE
NUMBER OF PONDS TO BE LOADED--EXAMPLE? 5')
790 READ (5,*)NPL
800 D) 3 J=1,NPL
810 WRITE (6,22)
830 READ (5,*)NP,ND
840 WRITE (6,23)
850 READ (5,*)DELTAL,ZLONG,ZKFACT,ESTCON
860 WRITE (6,35)
870 35 FORMAT(3X,'TYPE IN POND CHANGES/HOUR, POND VOLUME, MAXIMUM POUNDS OF FISH
/GPM, % DAILY MORTALITY.')
```

```

880 READ (5,*)RDELTA,VOL,WGPM,PCMORT
890 ZGPM=WGPM
900 WRITE (6,36)NP
910 36 FORMAT (20X,'WESTERS LOADING METHOD FOR POND ',I2/)
920 WRITE (6,26)ZLONG,ZKFACT
930 WRITE (6,27) DELTAL,ESTCON
940 WRITE (6,28) VOL ,PCMORT
950 WRITE (6,37)RDELTA,WGPM
960 37 FORMAT(3X,'POND CHANGES / HOUR = ',F5.3,T45,'LBS. FISH/GPM = ',5.2/)
980 WRITE (6,30)
990 ZLONG=ZLONG+DELTAL*(FLOAT(ND)-1.)
1000 ZNOLB=1./(ZKFACT*ZLONG**3)
1010 ZWEST=WGPM*RDELTA*VOL/8.
1020 ANUMB=ZWEST*ZNOLB/((1.-PCMORT/100.))**(FLOAT(ND)-1.)
```

```

1030 ZLONG=ZLONG-DELTA*(FLOAT(ND)-1.)
1040 FEDSUM=0.
1050 CALL FISH (FEDSUM,ZKFACT,ALONG,ANUMB,ESTCON,DELTA,PCMORT,ND,ZGPM)
1060 3 CONTINUE
1070 GO TO 75
1080 98 WRITE (6,38)
1090 38 FORMAT(3X,'YOU HAVE CHOSEN THE PIPER FLOW INDEX METHOD----TYPE IN
THE NUMBER OF PONDS TO BE LOADED--EXAMPLE? 5')
1100 READ (5,*) NPL
1110 DO 4 J=1,NPL
1120 WRITE (6,22)
1130 READ (5,*) NP,ND
1140 WRITE (6,24)
1150 READ (5,*)DELTA,ZLONG,ZKFACT,ESTCON
1160 WRITE (6,39)
1170 39 FORMAT(3X,'TYPE IN F-FACTOR, WATER TEMPERATURE, INFLOW (GPM), % DAILY
MORTALITY.')
```

```

1180 READ (5,*)ZFFACT,TEMP,ZGPM,PCMORT
1190 WRITE (6,40)NP
1200 40 FORMAT(17X,'PIPER FLOW INDEX METHOD FOR POND ',I2/)
1210 WRITE (6,26)ZLONG,ZKFACT
1220 WRITE (6,27)DELTA,ESTCON
1230 WRITE (6,41)ZGPM,TEMP
1240 41 FORMAT(3X,'INFLOW (GPM) = ',F6.1,T45,'WATER TEMPERATURE = ',F3.0/)
1250 WRITE(6,732)ZFFACT,PCMORT
1260 732 FORMAT(3X,'F-FACTOR = ',F5.2,T45,'% DAILY MORTALITY = ',F5.3/)
1280 WRITE (6,30)
1290 ZLONG=ZLONG+DELTA*(FLOAT(ND)-1.)
1300 ZNOLB=1./(ZKFACT*ZLONG**3)
1310 ZPF=ZFFACT*ZLONG*ZGPM
1320 ZNUMB=ZPF*ZNOLB/((1.-PCMORT/100.)*(FLOAT(ND)-1.))
1330 ZLONG=ZLONG-DELTA*(FLOAT(ND)-1.))
1340 FEDSUM=0.
1350 CALL FISH (FEDSUM,ZKFACT,ZLONG,ANUMB,ESTCON,DELTA,PCMORT,ND,ZGPM)
1360 4 CONTINUE
1370 GO TO 75
1380 126 WRITE (6,42)
1390 42 FORMAT(3X,'YOU HAVE CHOSEN THE WILLOUGHBY POND LOADING METHOD----TYPE
IN THE NUMBER OF PONDS TO BE LOADED--EXAMPLE? 5')
```

```

1400 READ (5,*)
1410 DO 5 J=1,NPL
1420 WRITE (6,22)
1430 READ (5,*)NP,ND
1440 WRITE (6,23)
1450 READ (5,*) DELTA,ZLONG,ZKFACT,ESTCON
1460 WRITE (6,430)
1470 430 FORMAT(3X,'TYPE IN OXYGEN AT INFLOW, OXYGEN AT OUTFALL, WATER
TEMPERATURE, INFLOW (GPM), % DAILY MORTALITY')
```

```

1480 READ (5,*)OIN,OOOUT,TEMP,ZGPM,PCMORT
1490 WRITE (6,44)NP
1500 44 FORMAT(18X,'WILLOUGHBY LOADING METHOD FOR POND ',I2/)
1510 WRITE (6,26)ZLONG,ZKFACT
1520 WRITE (6,27)DELTA,ESTCON
```

```
1530 WRITE (6,45) OIN,OOOT
1540 45 FORMAT(3X,'OXYGEN AT INFLOW = ',F4.1,T45,'OXYGEN AT OUTFALL = ',F4.1/)
1550 WRITE(6,460) ZGPM,TEMP
1560 460 FORMAT(3X,'INFLOW = ',F6.1,T45,'WATER TEMPERATURE = ',F3.0/)
1570 WRITE (6,30)
1580 ZLONG=ZLONG+DELTAL*(FLOAT(ND)-1.)
1590 ZNOLB=1./(ZKFACT*ZLONG**3)
1600 PWILL=(OIN-OOOT)*.0545*ZGPM
1610 PCBDWT=ESTCON*300.*DELTAL/ZLONG
1620 ZWILL-PWILL/(PCBDWT*.01)
1630 ZNUMB=ZWILL*ZNOLB/((1.-PCMORT/100.)**(FLOAT(ND)-1.))
1640 ZLONG=ZLONG-DELTAL*(FLOAT(ND)-1.)
1650 FEDSUM =0.
1660 CALL FISH (FEDSUM, ZKFACT, ZLONG, ZNUMB, ESTCON, DELTAL, PCMORT, ND, ZGPM)
1670 5 CONTINUE
1680 GO TO 75
1690 157 WRITE (6,46)
1700 46 FORMAT (3X,'YOU HAVE CHOSEN THE LIAO METHOD --TYPE IN THE NUMBER OF
PONDS TO BE LOADED--EXAMPLE? 5')
1710 READ (5,*)NPL
1720 WRITE (6,47)
1730 47 FORMAT(3X,'TYPE IN 1 FOR SALMON; 2 FOR TROUT.')
1740 READ (5,*)SPECIE
1750 DO 6 J=1,NPL
1760 WRITE (6,22)
1770 READ (5,*)NP,ND
1780 WRITE (6,23)
1790 READ (5,*)DELTAL, ZLONG, ZKFACT, ESTCON
1800 WRITE (6,430)
1810 READ (5,*)OIN,OOOT,TEMP,ZGPM,PCMORT
1820 WRITE (6,48)NP
1830 48 FORMAT(20X,'LIAO LOADING METHOD FOR POND ',I2/)
1840 WRITE (6,26)ZLONG,ZKFACT
1850 WRITE (6,27) DELTAL,ESTCON
1860 WRITE (6,45) OIN,OOOT
1870 WRITE(6,460) ZGPM,TEMP
1880 WRITE (6,30)
1890 ZLONG=ZLONG+DELTAL*(FLOAT(ND)-1.)
1900 W=ZKFACT*ZLONG**3
1910 ZNOLB=1./W
1920 IF(SPECIE.EQ.1.) GO TO 189
1930 ZM=-.138
1950 IF (TEMP.GE.50.) GO TO 186
1960 ZN=3.13
1970 GO TO 196
1980 186 ZK=.000305
1990 ZN=1.855
2000 GO TO 196
2010 189 ZM=-.194
2020 IF (TEMP.GE.50.) GO TO 194
2030 ZK=7.2E-07
2040 ZN=3.2
2050 GO TO 196
2060 194 ZK=.000049
```

```
2070 ZN=2.12
2080 196 ZLIAO=ZGPM*1.2*(OIN-OOUT)/(ZK*TEMP**ZN*W**ZM)
2090 ZNUMB=ZLIAO*ZNOLB/((1.-PCMORT/100.)**(FLOAT(ND)-1.))
2100 ZLONG=ZLONG-DELTAL*(FLOAT(ND)-1.)
2110 FEDSUM = 0.
2120 CALL FISH (FEDSUM, ZKFACT, ZLONG, ANUMB, ESTCON, DELTAL, PCMORT, ND, ZGPM)
2130 6 CONTINUE
2140 75 CONTINUE
2150 END
2160 SUBROUTINE FISH (FEDSUM, ZKFACT, ZLONG, ZNUMB, ESTCON, DELTAL, PCMORT, ND, ZGPM)
2170 DO 15 I=1, ND
2180 ZNOLB=1./(ZKFACT*ZLONG**3)
2190 TOTWT-ZNUMB/ZNOLB
2200 PCBDWT=ESTCON*300.*DELTAL/ZLONG
2210 FOODFD=TOTWT*PCBDWT/100.
2220 FEDSUM=FEDSUM+FOODFD
2280 WRITE(6,750)*, TOTWT, ZNOLB, ZLONG, PCBDWT, FOODFD, ZNUMB
2300 750 FORMAT(1X, *3, F10.2, F8.2, F7.2, F10.2, F8.1, F9.0/)
2310 ZLONG=ZLONG+DELTAL
2320 ZNUMB=ZNUMB-(ZNUMB*(PCMORT/100.))
2330 15 CONTINUE
2340 WRITE (6,76)FEDSUM
2350 76 FORMAT(2X, 'TOTAL FEED FOR PERIOD = ', F12.2, 'POUNDS'/)
2360 RETURN
2370 END
```

APPENDIX IV

List of IRV Fish Culture Program

IRV

```

100 WRITE(6,20)
110 20 FORMAT(3X,'TYPE IN THE POND LOADING FORMULA YOU WISH TO USE---TYPE
IN 1 FOR WILLOUGHBY; 2 FOR WESTERS; 3 FOR LIAO; 4 FOR PIPER DENSITY INDEX
METHOD; 5 FOR PIPER FLOW INDEX METHOD; and 6 FOR KLONTZ')
120 READ(5,*)LL
130 IF(LL.EQ.1) GO TO 126
140 IF(LL .EQ. 2) GO TO 71
150 IF(LL .EQ. 3) GO TO 157
160 IF(LL .EQ. 4) GO TO 43
170 IF(LL.EQ.5) GO TO 98
180 WRITE(6,21)
190 21 FORMAT(3X,'YOU HAVE CHOSEN THE KLONTZ LOADING FORMULA--TYPE IN THE
NUMBER OF PONDS TO BE LOADED--EXAMPLE ++? 5')
200 READ(5,*)NPL
210 DO 1 J=1,NPL
220 WRITE(6,22)
230 22 FORMAT(3X,'TYPE IN POND NUMBER AND HOW MANY DAYS THE PERIOD IS TO
RUN---- EXAMPLE? 10,14')
240 READ(5,*)NP,ND
250 WRITE(6,23)
260 23 FORMAT(3X,'TYPE IN DELTA L, FISH LENGTH, K-FACTOR, ESTIMATED CONVERSION')
270 READ(5,*)DELTAL,ZLONG,ZKFACT,ESTCON
280 WRITE(6,24)
290 24 FORMAT(3X,'TYPE IN POND VOLUME,POND CHANGES/HOUR,PLI NUMBER,% DAILY
MORTALITY.')
```

```

300 READ (5,*)VOL,RDELTA,PLI,PCMORT
302 WRITE(6,240)
304 240 FORMAT(3X,'TYPE IN WATER TEMPERATURE AND PH')
306 READ(5,*)F,PH
310 WRITE(6,25)NP
320 25 FORMAT(20X,'KLONTZ LOADING METHOD FOR POND ',I2/)
330 WRITE(6,26)ZLONG,ZKFACT
340 26 FORMAT(3X,'STARTING FISH LENGTH = ',F6.4,T45,'K-FACTOR = ',F7.6/)
350 WRITE(6,27)DELTAL,ESTCON
360 27 FORMAT(3X,'DELTA L = ',F6.4,T45,'ESTIMATED CONVERSION = ',F5.3/)
370 WRITE(6,28)VOL,PCMORT
380 28 FORMAT(3X,'POND VOLUME = ',F9.2,T45,'% DAILY MORTALITY - ',F5.3/)
390 WRITE(6,29)PLI,RDELTA
400 29 FORMAT(3X,'PLI NUMBER = ',F4.3,T45,'POND CHANGES/HOUR = ',F5.3/)
410 WRITE(6,295)
420 295 FORMAT(T50,'LBS SOLIDS/',T68,'FREE')
```

```

430 WRITE(6,30)
440 30 FORMTA(2X,'DAY POND WT. NO/LB LENGTH % BW FEED FISH 100#FISH
NH3-N NH3' /)
450 ZLONG=ZLONG+DELTAL*(FLOAT(ND)-1.)
460 ZNOLB=1./(ZKFACT*ZLONG**3)
470 ZPLI=VOL*RDELTA*ZLONG*PLI
480 ZNUMB=ZPLI*ZNOLB/((1.-PCMORT/100.))**(FLOAT(ND)-1.)
490 ZLONG=ZLONG-DELTAL*(FLOAT(ND)-1.)
500 FEDSUM=0.
510 ZGPM=VOL*RDELTA*7.5/60.
520 CALL FISH (FEDSUM,ZKFACT,ZLONG,ZNUMB,ESTCON,DELTAL,PCMORT,ND,ZGPM,F,PH)
530 1 CONTINUE
540 GO TO 75
```

```
550 43 WRITE(6,31)
560 31 FORMAT(3X,'YOU HAVE CHOSEN THE PIPER DENSITY INDEX METHOD---TYPE
IN THE NUMBER TO BE LOADED---EXAMPLE ? 5')
580 READ(5,*)NPL
590 DO 2 J=1,NPL
600 WRITE (6,22)
610 READ(5,*)NP,ND
620 WRITE(6,23)
630 READ(5,*)DELTAL,ZLONG,ZKFACT,ESTCON
640 WRITE(6,32)
650 32 FORMAT(3X,'TYPE IN POND VOLUME,WATER TEMPERATURE,MAXIMUM DENSITY
INDEX, % DAILY MORTALITY,POND TURNOVERS/HR')
660 READ(5,*)VOL,TEMP,DI,PCMORT,RDELTA
662 WRITE(6,244)
664 READ(5,*)PH
670 WRITE(6,33)NP
680 33 FORMAT(20X,'PIPER DENSITY INDEX METHOD FOR POND ',I2/)
690 WRITE (6,26) ZLONG,ZKFACT
700 WRITE (6,27) DELTAL,ESTCON
710 WRITE (6,34) DI,TEMP
720 34 FORMAT(3X,'MAXIMUM DENSITY INDEX = ',F4.3,T45,'WATER TEMPERATURE =
',F3.0/)
730 WRITE (6,28) VOL,PCMORT
740 WRITE(6,295)
750 WRITE (6,30)
760 ZLONG=ZLONG+DELTAL*(FLOAT(ND)-1.)
770 ZMDI=ZLONG*VOL*DI
780 ZNOLB=1./(ZKFACT*ZLONG**3)
790 ZNUMB=ZMDI*ZNOLB/((1.-PCMORT/100.)**(FLOAT(ND)-1.))
800 ZLONG=ZLONG-DELTAL*(FLOAT(ND)-1.)
805 F=TEMP
810 FEDSUM=0.
820 ZGPM=VOL*RDELTA*7.5/60.
830 CALL FISH (FEDSUM,ZKFACT,ZLONG,ZNUMB,ESTCON,DELTAL,PCMORT,ND,ZGPM,F,PH)
840 2 CONTINUE
850 GO TO 75
860 71 WRITE (6,99)
870 99 FORMAT(3X,'YOU HAVE CHOSEN THE WESTERS LOADING FORMULA---TYPE IN THE
NUMBER OF PONDS TO BE LOADED--EXAMPLE? 5')
880 READ (5,*)NPL
890 DO 3 J=1,NPL
900 WRITE (6,22)
920 READ (5,*)NP,ND
930 WRITE (6,23)
940 READ (5,*)DELTAL,ZLONG,ZKFACT,ESTCON
950 WRITE (6,35)
960 35 FORMAT(3X,'TYPE IN POND CHANGES/HOUR, POND VOLUME, MAXIMUM POUNDS OF
FISH/GPM, % DAILY MORTALITY.')
```



```
1904 READ(5,*)PH
1906 F=TEMP
1910 WRITE (6,48(NP
1920 48 FORMAT(20X,'LIAO LOADING METHOD FOR POND ',I2/)
1930 WRITE (6,26)ZLONG,ZKFACT
1940 WRITE (6,27) DELTAL,ESTCON
1950 WRITE (6,45) OIN,OOOUT
1960 WRITE(6,460)ZGPM,TEMP
1965 WRITE(6,295)
1970 WRITE (6,30)
1980 ZLONG=ZLONG+DELTAL*(FLOAT(ND)-1.)
1990 W=ZKFACT*ZLONG**3
2000 ZNOLB=1./W
2010 IF(SPECIE.EQ.1.) GO TO 189
2020 ZM=-.138
2030 IF (TEMP.GE.50.) GO TO 186
2040 ZK=.0000019
2050 ZN=3.13
2060 GO TO 196
2070 186 ZK=.000305
2080 ZN=1.855
2090 GO TO 196
2100 189 ZM=-.194
2110 IF (TEMP.GE.50.) GO TO 194
2120 ZK=7.2E-07
2130 ZN=3.2
2140 GO TO 196
2150 194 ZK=.000049
2160 ZN=2.12
2170 196 ZLIAO=ZGPM*1.2*(OIN-OOOUT/(ZK*TEMP**ZN*W**ZM)
2180 ZNUMB=ZLIAO*ZNOLB/((1.-PCMORT/100.)*(FLOAT(ND)-1.))
2190 ZLONG=ZLONG-DELTAL*(FLOAT(ND)-1.)
2200 FEDSUM = 0.
2210 CALL FISH (FEDSUM,ZKFACT,ZLONG,ZNUMB,ESTCON,DELTAL,PCMORT,ND,ZGPM,F,PH)
2220 6 CONTINUE
2230 75 CONTINUE
2240 END
2250 SUBROUTINE FISH (FEDSUM,ZKFACT,ZLONG,ZNUMB,ESTCON,DELTAL,PCMORT,ND,ZGPM,F,PH)
2260 DO 15 I=1,ND
2263 NTEMP=5*(F-3s.)/9.
2266 IF(NTEMP .LT. 4)NTEMP=4
2268 NNUM=NTEMP-4
2270 ZNOLB=1./(ZKFACT*ZLONG**3)
2272 IF(PH .LT. 6.5)PH=6.5)
2274 IF(PH .GT. 9.9)PH=9.0)
2276 AMONK=(NNUM*.0157+1.48)
2278 WATERK=(NNUM*.398+1.735)*10**(-5)
2279 QATERK=NNUM*.398+1.735
2280 TOTWT=ZNUMB/ZNOLB
2290 PCBDWT=ESTCON*300.*DELTAL/ZLONG
2300 FOODFD=TOTWT*PCBDWT/100.
2310 FEDSUM=FEDSUM+FOODFD
```

```

1460 GO TO 75
1470 126 WRITE (6,42)
1480 42 FORMAT(3X,'YOU HAVE CHOSEN THE WILLOUGHBY POND LOADING METHOD---
TYPE IN THE NUMBER OF PONDS TO BE LOADED--EXAMPLE? 5')
1490 READ (5,*)NPL
1500 DO 5 J=1,NPL
1510 WRITE (6,22)
1520 READ (5,*)NP,ND
1530 WRITE (6,23)
1540 READ (5,*) DELTAL,ZLONG,ZKFACT,ESTCON
1550 WRITE (6,430)
1560 430 FORMAT(3X,'TYPE IN OXYGEN AT INFLOW, OXYGEN AT OUTFALL, WATER
TEMPERATURE, INFLOW (GPM), % DAILY MORTALITY')
1570 READ (5,*)OIN,OOOUT,TEMP,ZGPM,PCMORT
1572 WRITE(6,244)
1574 READ(5,*)PH
1576 F=TEMP
1580 WRITE (6,44)NP
1590 44 FORMAT(18X,'WILLOUGHBY LOADING METHOD FOR POND ',I2/)
1600 WRITE (6,26)ZLONG,ZKFACT
1610 WRITE (6,27) DELTAL,ESTCON
1620 WRITE (6,45) OIN,OOOUT
1630 45 FORMAT(3X,'OXYGEN AT INFLOW = ',F4.1,T45,'OXYGEN AT OUTFALL = ',F4.1/)
1640 WRITE(6,460)ZGPM,TEMP
1650 460 FORMAT(3X,'INFLOW = ',F6.1,T45,'WATER TEMPERATURE = ',F3.0/)
1655 WRITE(6,295)
1660 WRITE (6,30)
1670 ZLONG=ZLONG+DELTAL*(FLOAT(ND)-1.)
1680 ZNOLB=1./(ZKFACT*ZLONG**3)
1690 PWILL=(OIN-OOOUT)*.0545*ZGPM
1700 PCBDWT=ESTCON*300.DELTAL/ZLONG
1710 ZWILL=PWILL/(PCBDWT*.01)
1720 ZNUMB-ZWILL*ZNOLB/((1.-PCMORT/100.))**(FLOAT(ND)-1.)
1730 ZLONG=ZLONG-DELTAL*(FLOAT(ND)-1.)
1740 FEDSUM =0.
1750 CALL FISH (FEDSUM,ZKFACT,ZLONG,ZNUMB,ESTCON,DELTAL,PCMORT,ND,ZGPM,F,PH)
1760 5 CONTINUE
1770 GO TO 75
1780 157 WRITE (6,46)
1790 46 FORMAT (3X,'YOU HAVE CHOSEN THE LIAO METHOD --TYPE IN THE NUMBER OF
PONDS TO BE LOADED--EXAMPLE? 5')
1800 READ (5,*)NPL
1810 WRITE (6,47)
1820 47 FORMAT(3X,'TYPE IN 1 FOR SALMON; 2 FOR TROUT.')
1830 READ (5,*)SPECIE
1840 DO 6 J=1,NPL
1850 WRITE (6,22)
1860 READ (5,*)NP,ND
1870 WRITE (6,23)
1880 READ (5,*)DELTAL,ZLONG,ZKFACT,ESTCON
1890 WRITE (6,430)
1900 READ (5,*)OIN,OOOUT,TEMP,ZGPM,PCMORT
1902 WRITE (6,244)

```

```

1000 36 FORMAT (20X, 'WESTERS LOADING METHOD FOR POND ', I2/)
1010 WRITE (6,26) ZLONG, ZKFACT
1020 WRITE (6,27) DELTAL, ESTCON
1030 WRITE (6,28) VOL , PCMORT
1040 WRITE (6,37) RDELTA, WGPM
1050 37 FORMAT(3X, 'POND CHANGES / HOUR - ', F5.3, T45, 'LBS. FISH/GPM - ', F5.2/)
1060 WRITE(6,295)
1070 WRITE (6,30)
1080 ZLONG=ZLONG+DELTAL*(FLOAT(ND)-1.)
1090 ZNOLB=1./(ZKFACT*ZLONG**3)
1100 ZWEST=WGPM*RDELTA*VOL/8.
1110 ZNUMB=ZWEST*ZNOLB/((1.-PCMORT/100.）** (FLOAT(ND)-1.))
1120 ZLONG=ZLONG-DELTAL*(FLOAT(ND)-1.)
1125 ZGPM=VOL*RDELTA*7.5/60.
1130 FEDSUM=0.
1140 CALL FISH (FEDSUM, ZKFACT, ZLONG, ZNUMB, ESTCON, DELTAL, PCMORT, ND, ZGPM, F, PH)
1150 3 CONTINUE
1160 GO TO 75
1170 98 WRITE (6,38)
1180 38 FORMAT(3X, 'YOU HAVE CHOSEN THE PIPER FLOW INDEX METHOD-----TYPE IN
THE NUMBER OF PONDS TO BE LOADED--EXAMPLE? 5')
1190 READ (5,*) NPL
1200 DO 4 J=1, NPL
1210 WRITE (6,22)
1220 READ (5,*) NP, ND
1230 WRITE (6,23)
1240 READ (5,*) DELTAL, ZLONG, ZKFACT, ESTCON
1250 WRITE (6,39)
1260 39 FORMAT(3X, 'TYPE IN F-FACTOR, WATER TEMPERATURE, INFLOW (GPM), % DAILY
MORTALITY. ')
1270 READ (5,*) ZFFACT, TEMP, ZGPM, PCMORT
1272 WRITE(6,244)
1274 244 FORMAT(3X, 'TYPE IN PH OF WATER')
1276 READ(5,*) PH
1278 F=TEMP
1280 WRITE (6,40) NP
1290 40 FORMAT(17X, 'PIPER FLOW INDEX METHOD FOR POND ', I2/)
1300 WRITE (6,26) ZLONG, ZKFACT
1310 WRITE (6,27) DELTAL, ESTCON
1320 WRITE (6,41) ZGPM, TEMP
1330 41 FORMAT(3X, 'INFLOW (GPM) = ', F6.1, T45, 'WATER TEMPERATURE = ', F3.0/)
1340 WRITE(6,732) ZFFACT, PCMORT
1350 732 FORMAT(3X, 'F-FACTOR = ', F5.2, T45, '% DAILY MORTALITY = ', F5.3/)
1360 WRITE(6,295)
1370 WRITE (6,30)
1380 ZLONG=ZLONG+DELTAL*(FLOAT(ND)-1.)
1390 ZNOLB=1./(ZKFACT*ZLONG**3)
1400 ZPF=ZFFACT*ZLONG*ZGPM
1410 ZNUMB=ZPF*ZNOLB/((1.-PCMORT/100.）** (FLOAT(ND)-1.))
1420 ZLONG=ZLONG-DELTAL*(FLOAT(ND)-1.)
1430 FEDSUM =0.
1440 CALL FISH (FEDSUM, ZKFACT, ZLONG, ZNUMB, ESTCON, DELTAL, PCMORT, ND, ZGPM, F, PH)
1450 4 CONTINUE

```

```
2320 SOLIDS=.95*FOODFD*(1-1/ESTCON)
2330 SLD=(SOLIDS/TOTWT)*100.
2340 WLSLDS=SOLIDS/(.012*ZGPM)
2350 AMONYA=.032*FOODFD
2360 WILAMO=AMONYA/(.012*ZGPM)
2366 PPH=PH-5.
2368 SUB1=(10**(-PPH))*1000
2370 SUB2=WATERK/SUB1
2372 SUB3=SUB2/AMONK
2374 AMOPCT=SUB3*.77
2378 AMONH3=AMOPCT*WILAMO/100.
2380 WRITE(6,750)I,TOTWT,ZNOLB,ZLONG,PCBDWT,FOODFD,ZNUMB,SLD,WILAMO,AMONH3
2390 750 FORMAT(1X,I3,F10.1,F8.2,F7.3,F7.2,F7.1,F8.0,2F7.3,F8.5/)
2400 ZLONG=ZLONG+DELTAL
2410 ZNUMB=ZNUMB-(ZNUMB*(PCMORT.100.))
2420 15 CONTINUE
2430 WRITE (6,76)FEDSUM
2440 76 FORMAT(2X,'TOTAL FEED FOR PERIOD = ',F12.2,'POUNDS'/)
2450 RETURN
2460 END
```

APPENDIX V

Computer Output Specimen Using the OWRT Program.

ROOM NUMBER 2A TANK NUMBER 1

DELTA = 0.0350

TEMPERATURE = 59.

EST. CONVERSION = 1.500

POND CHANGES/HOUR = 2.500

STARTING FISH LENGTH = 3.0000

#/LB = 101.000

POND VOLUME = 3.690

DENSITY INDEX = 0.500

K-FACTOR = 0.000410

% DAILY MORTALITY = 0.030

DAY	POND WEIGHT	NO./LB	LENGTH	% BW FED	FEED	NO. FISH
1	4.19	90.33	3.00	5.25	106.48	378.
2	4.34	87.25	3.03	5.19	108.82	378.
3	4.49	84.29	3.07	5.13	111.19	378.
4	4.64	81.48	3.10	5.07	113.59	378.
5	4.80	78.78	3.14	5.02	116.01	378.
6	4.97	76.21	3.17	4.96	118.47	378.
7	5.13	73.74	3.21	4.91	120.95	378.
8	5.30	71.38	3.24	4.85	129.15	378.
9	5.48	69.12	3.28	4.80	151.68	378.
10	5.65	66.95	3.31	4.75	134.24	378.
11	5.83	64.88	3.35	4.70	136.83	378.
12	6.02	62.88	3.38	4.65	139.45	378.
13	6.21	60.97	3.42	4.61	142.09	378.
14	6.40	59.14	3.45	4.56	0.0	378.

TOTAL FEED FOR PERIOD = 1603.95GRAMS

APPENDIX VI

Computer Output Exhibits Using the IRV Program

Input Data:

Fish - rainbow trout

length - 2.67"

Density Factor - 0.4

l - 0.03"/day

K-Factor 4.1×10^{-4}

daily mortality (est.) - 0.03%

Water - temp. 59° F

inflow - 775 gpm (1.72 cfs)

water replacement time - 28.5 min.

elevation - 1000' above MSL

DO in - 9.6 mg/l

DO out - 6.0 mg/l

pH - 8.0

Pond - volume - 3000 ft^3

Feed - conversion (est.) - 1.6

WILLOUGHBY LOADING METHOD FOR POND 1

STARTING FISH LENGTH = 2.6700

K-FACTOR = .000400

DELTA L = 0.0300

ESTIMATED CONVERSION = 1.600

OXYGEN AT INFLOW = 9.6

OXYGEN AT OUTFALL = 6.0

INFLOW = 775.0

WATER TEMPERATURE = 59.

DAY	POND WT.	NO/LB	LENGTH	% BW	FEED	FISH	LBS SOLIDS/ 100#FISH	NH3-N	FREE NH3
1	2154.9	131.34	2.670	5.39	116.2	283028.	1.921	0.400	0.00361
2	2227.7	127.01	2.700	5.33	118.8	282943.	1.900	0.409	0.00369
3	2302.1	122.87	2.730	5.27	121.4	282858.	1.879	0.418	0.00377
4	2378.1	118.91	2.760	5.22	124.1	282773.	1.859	0.427	0.00385
5	2455.7	115.11	2.790	5.16	126.7	282689.	1.839	0.436	0.00394
6	2535.0	111.48	2.820	5.11	129.4	282604.	1.819	0.445	0.00402
7	2616.0	108.00	2.850	5.05	132.2	282519.	1.800	0.455	0.00411
8	2698.7	104.66	2.880	5.00	134.9	282434.	1.781	0.464	0.00419
9	2783.1	101.45	2.910	4.95	137.7	282349.	1.763	0.474	0.00428
10	2869.2	98.38	2.940	4.90	140.5	282265.	1.745	0.484	0.00436
11	2957.0	95.43	2.970	4.85	143.4	282180.	1.727	0.493	0.00445
12	3046.6	92.59	3.000	4.80	146.2	282095.	1.710	0.503	0.00454
13	3138.0	89.87	3.030	4.75	149.1	282011.	1.693	0.513	0.00463
14	3231.2	87.25	3.060	4.71	152.1	281926.	1.676	0.523	0.00472

TOTAL FEED FOR PERIOD = 1872.88 POUNDS

WESTERS LOADING METHOD FOR POND 1

STARTING FISH LENGTH = 2.6700

K-FACTOR = .000410

DELTA L = 0.0300

ESTIMATED CONVERSION = 1.600

POND VOLUME = 3000.00

% DAILY MORTALITY = 0.030

POND CHANGES/HOUR = 2.100

LBS. FISH/GPM = 4.28

DAY	POND WT.	NO/LB	LENGTH	% BW	FEED	FISH	LBS SOLIDS/ 100#FISH	NH3-N	FREE NH3
1	2247.8	128.14	2.670	5.39	121.2	288032.	1.921	0.411	0.01169
2	2323.7	123.92	2.700	5.33	123.9	287945.	1.900	0.420	0.01196
3	2401.3	119.88	2.730	5.27	126.7	287859.	1.879	0.429	0.01222
4	2480.6	116.01	2.760	5.22	129.4	287773.	1.859	0.438	0.01248
5	2561.6	112.31	2.790	5.16	132.2	287686.	1.839	0.448	0.01275
6	2644.3	108.76	2.820	5.11	135.0	287600.	1.819	0.457	0.01302
7	2728.8	105.36	2.850	5.05	137.9	287514.	1.800	0.467	0.01330
8	2815.1	102.10	2.880	5.00	140.8	287427.	1.781	0.477	0.01357
9	2903.1	98.98	2.910	4.95	143.7	287341.	1.763	0.486	0.01385
10	2992.9	95.98	2.940	4.90	146.6	287255.	1.745	0.496	0.01414
11	3084.5	93.10	2.970	4.85	149.6	287169.	1.727	0.506	0.01442
12	3178.0	90.33	3.000	4.80	152.5	287082.	1.710	0.517	0.01471
13	3273.3	87.68	3.030	4.75	155.6	286996.	1.693	0.527	0.01500
14	3370.5	85.12	3.060	4.71	158.6	286910.	1.676	0.537	0.01530

TOTAL FEED FOR PERIOD = 1953.64 POUNDS

LIAO LOADING METHOD FOR POND 1

STARTING FISH LENGTH = 2.6700

K-FACTOR = .000410

DELTA L = 0.0300

ESTIMATED CONVERSION = 1.600

OXYGEN AT INFLOW = 9.6

OXYGEN AT OUTFALL = 6.0

INFLOW = 775.0

WATER TEMPERATURE = 59.

DAY	POND WT.	NO/LB	LENGTH	% BW	FEED	FISH	LBS SOLIDS/ 100#FISH	NH3-N	FREE NH3
1	2057.2	123.14	2.670	5.39	110.9	263606.	1.921	0.382	0.00345
2	2126.7	123.92	2.700	5.33	113.4	263527.	1.900	0.390	0.00352
3	2197.7	119.88	2.730	5.27	115.9	263448.	1.879	0.399	0.00360
4	2270.3	116.01	2.760	5.22	118.4	263369.	1.859	0.408	0.00368
5	2344.4	112.31	2.790	5.16	121.0	263290.	1.839	0.416	0.00376
6	2420.1	108.76	2.820	5.11	123.6	263211.	1.819	0.425	0.00384
7	2497.4	105.36	2.850	5.05	126.2	263132.	1.800	0.434	0.00392
8	2576.3	102.10	2.880	5.00	128.8	263053.	1.781	0.443	0.00400
9	2646.9	98.98	2.190	4.95	131.5	262974.	1.763	0.452	0.00408
10	2739.1	95.98	2.940	4.90	134.2	262895.	1.745	0.462	0.00417
11	2822.9	93.10	2.970	4.85	136.9	262816.	1.727	0.471	0.00425
12	2908.5	90.33	3.000	4.80	139.6	262737.	1.710	0.480	0.00434
13	2995.7	87.68	3.030	4.75	142.4	262658.	1.693	0.490	0.00442
14	3084.7	85.12	3.060	4.71	145.2	262579.	1.676	0.499	0.00451

TOTAL FEED FOR PERIOD = 1787.97 POUNDS

PIPER DENSITY INDEX METHOD FOR POND 1

STARTING FISH LENGTH = 2.6700

K-FACTOR = .000410

DELTA L = 0.0300

ESTIMATED CONVERSION = 1.600

MAXIMUM DENSITY INDEX = .400

WATER TEMPERATURE = 59.

POND VOLUME = 3000.00

% DAILY MORTALITY = 0.030

DAY	POND WT.	NO/LB	LENGTH	% BW	FEED	FISH	LBS SOLIDS/ 100#FISH	NH3-N	FREE NH3
1	2448.9	128.14	2.670	5.39	132.1	313797.	1.921	0.447	0.00404
2	2531.6	123.92	2.700	5.33	135.0	313703.	1.900	0.457	0.00413
3	2616.1	119.88	2.730	5.27	138.0	313608.	1.879	0.467	0.00422
4	2702.5	116.01	2.760	5.22	141.0	313514.	1.859	0.477	0.00431
5	2790.8	112.31	2.790	5.16	144.0	313420.	1.839	0.488	0.00440
6	2880.9	108.76	2.820	4.11	147.1	323326.	1.819	0.498	0.00450
7	2972.9	105.36	2.850	5.05	150.2	313232.	1.800	0.509	0.00459
8	3066.9	102.10	2.830	5.00	153.3	313138.	1.781	0.519	0.00469
9	3162.8	98.98	2.910	4.95	156.5	313044.	1.763	0.530	0.00478
10	3260.6	95.98	2.940	4.90	159.7	312950.	1.745	0.541	0.00488
11	3360.4	93.10	2.970	4.85	162.9	312856.	1.727	0.552	0.00498
12	3462.3	90.33	3.000	4.80	166.2	312762.	1.710	0.563	0.00508
13	3566.1	87.68	3.030	4.75	169.5	312669.	1.693	0.574	0.00518
14	3672.0	85.12	3.060	4.71	172.8	312575.	1.676	0.585	0.00528

TOTAL FEED FOR PERIOD = 2128.40 POUNDS

PIPER FLOW INDEX METHOD FOR POND 1

STARTING FISH LENGTH = 2.6700

K-FACTOR = .000410

DELTA L = 0.0300

ESTIMATED CONVERSION = 1.600

OXYGEN AT INFLOW = 775.0

WATER TEMPERATURE = 59.

INFLOW = 1.32

% DAILY MORTALITY = 0.030

DAY	POND WT.	NO/LB	LENGTH	% BW	FEED	FISH	LBS SOLIDS/ 100#FISH	NH3-N	FREE NH3
1	2087.7	128.14	2.670	5.39	112.6	267512.	1.921	0.387	0.00350
2	2158.2	124.92	2.700	5.33	115.1	267432.	1.900	0.396	0.00358
3	2230.2	119.88	2.730	5.27	117.6	267351.	1.869	0.405	0.00365
4	2303.9	116.01	2.760	5.22	120.2	267271.	1.859	0.414	0.00373
5	2379.1	112.31	2.790	5.16	122.8	267191.	1.839	0.423	0.00381
6	2456.0	108.76	2.820	5.11	125.4	267111.	1.819	0.432	0.00390
7	2534.4	105.26	2.850	5.05	128.1	267030.	1.800	0.441	0.00398
8	2614.5	102.10	2.880	5.00	130.7	267950.	1.781	0.450	0.00406
9	2696.3	98.98	2.910	4.95	133.4	266870.	1.763	0.459	0.00414
10	2779.7	95.98	2.940	4.90	136.1	266790.	1.745	0.468	0.00423
11	2864.8	93.10	2.970	4.85	138.9	266710.	1.727	0.478	0.00431
12	2951.6	90.33	3.000	4.80	141.7	266630.	1.719	0.487	0.00440
13	3040.1	87.68	3.030	4.75	144.5	266550.	1.693	0.497	0.00449
14	3130.4	85.12	3.060	4.71	147.3	266470.	1.676	0.507	0.00458

TOTAL FEED FOR PERIOD = 1814.46 POUNDS

KLONTZ LOADING METHOD FOR POND 1

STARTING FISH LENGTH = 2.6700

K-FACTOR = .000410

DELTA L = 0.0300

ESTIMATED CONVERSION = 1.600

POND VOLUME = 3000.00

% DAILY MORTALITY = 0.030

PLI NUMBER = .165

POND CHANGES/HOUR =2.100

DAY	POND WT.	NO/LB	LENGTH	% BW	FEED	FISH	LBS SOLIDS/ 100#FISH	NH3-N	FREE NH3
1	2121.3	123.14	2.670	5.39	114.4	271827.	1.921	0.387	0.00110
2	2193.0	123.92	2.700	5.33	117.0	271745.	1.900	0.396	0.00113
3	2266.2	119.88	3.730	5.27	119.5	271663.	1.879	0.405	0.00115
4	2341.1	116.01	2.760	5.22	122.1	271582.	1.859	0.414	0.00118
5	2417.5	112.31	2.790	5.16	124.8	271500.	1.839	0.423	0.00120
6	2495.6	108.76	2.820	5.11	127.4	271419.	1.819	0.432	0.00123
7	2575.3	105.36	2.850	5.05	130.1	271338.	1.800	0.441	0.00125
8	2656.7	102.10	2.880	5.00	132.8	271256.	1.781	0.450	0.00128
9	2739.7	98.98	2.910	4.95	135.6	271175.	1.763	0.459	0.00131
10	2824.5	95.98	2.940	4.90	138.3	271093.	1.745	0.468	0.00133
11	2911.0	93.10	2.970	4.85	141.1	271012.	1.727	0.478	0.00136
12	2999.2	90.33	3.000	4.80	144.0	270931.	1.710	0.487	0.00139
13	3089.1	87.68	3.030	4.75	146.8	270849.	1.693	0.497	0.00142
14	3180.9	85.12	3.060	4.71	149.7	270768.	1.676	0.507	0.00144

TOTAL FEED FOR PERIOD = 1843.72 POUNDS