

CHARACTERIZATION OF GROUND WATER FLOW IN THE LOWER BOISE RIVER BASIN

Prepared by

Christian R. Petrich

Idaho Water Resources Research Institute
University of Idaho

Scott M. Urban

Idaho Department of Water Resources

Prepared for and in cooperation with the

Idaho Department of Water Resources

1301 North Orchard
Boise, Idaho 83706-2237



FEBRUARY 2004

**IDAHO WATER RESOURCES RESEARCH INSTITUTE
RESEARCH REPORT**

IWRRI-2004-01



ACKNOWLEDGEMENTS

The work described in this report was conducted as part of the Treasure Valley Hydrologic Project (TVHP). Participants in the TVHP include the Idaho Department of Water Resources (IDWR), the Idaho Water Resources Research Institute (IWRRI), University of Idaho (UI), United Water Idaho, Inc. (UWID), Boise State University (BSU), U.S. Geological Survey (USGS), U.S. Bureau of Reclamation (USBR), Idaho Water Resources Board (IWRB), Ada and Canyon Counties, and the cities of Boise, Nampa, Caldwell, Meridian, Kuna, and Eagle. The project was funded by the U.S. Environmental Protection Agency, the Idaho State Legislature, UWID, and the IWRB. In addition, substantial in-kind services were provided by UWID, the USGS, and the USBR.

The authors wish to acknowledge the following contributions to this report:

- Helen Harrington and Shane Bendixsen (IDWR) prepared hydrographs of water level data from Treasure Valley wells.
- Linda Davis and Genna Ashley-Poulson provided GIS support and assistance.
- Diana Hegland provided proofreading and editing assistance.
- The citizens of the Treasure Valley, who helped pay for this effort.

This report was reviewed by:

- Hal Anderson (IDWR)
- Paul Castelin (IDWR)
- Garth Newton (IDWR)
- Dr. David Tuthill (IDWR)
- Ed Squires (Hydro Logic, Inc.)

EXECUTIVE SUMMARY

The Treasure Valley Hydrologic Project (TVHP) was a multi-year study to develop a better understanding of ground water resources in the lower Boise River basin (Treasure Valley) of southwestern Idaho. This report presents, as part of the TVHP, a summary of hydrologic conditions in the Treasure Valley aquifer system. The report describes (1) Treasure Valley aquifer characteristics, (2) multi-level ground water monitoring wells installed as part of the TVHP, (3) results from water level measurements, and (5) aquifer inflows and outflows. The report concludes with a description of ground water flow in Treasure Valley aquifers. This conceptual model of ground water flow forms the basis for a series of numerical simulations (Petrich, 2004a; Petrich, 2004b) conducted as part of the TVHP.

The Treasure Valley aquifer system resides in a complex series of interbedded, tilted, faulted, and eroded sediments extending to depths of over 6,000 feet (Wood and Clemens, in press). These sedimentary aquifers contain shallow, local flow systems (with ground water residence times ranging from days to tens of years), and a deep, regional flow system (with residence times ranging from hundreds to tens of thousands of years). Only a few wells extend beyond a depth of 1,200 feet.

Water levels indicate general ground water movement in a westerly to southwesterly direction. Individual hydrographs indicate relatively stable water levels in many areas. Some areas, such as southeast Boise and an area south of Lake Lowell, have experienced water level declines of approximately 30 and 65 feet, respectively. A number of wells in other areas (primarily in the eastern portion of the valley) have also experienced water level declines over the last several years. These declines have generally been less than 10 feet.

The largest component of recharge to shallow aquifers is seepage from the canal system and infiltration associated with irrigated agriculture. Recharge to the deeper aquifer occurs in the eastern portion of the valley and along the Boise Front. Ground water discharge to rivers, drains, and canals represents the dominant form of discharge from the Treasure Valley aquifer system. The primary form of natural discharge from the deeper aquifers is thought to be regional upwelling in the southern and western portions of the basin, with ultimate discharge to the Boise River and/or Snake River.

Ground water residence times in the deeper, regional aquifer system were found to increase with depth and with distance along a regional east-to-west-trending flow path. Residence time estimates ranged from thousands to tens of thousands of years.

Relatively long residence times in the regional flow system (over 20,000 years) imply that (1) regional aquifers are marginally transmissive, (2) recharge rates to the deeper regional aquifers are limited, and/or (3) regional aquifers are discharge-limited. Although there are abundant silt and clay layers with low hydraulic conductivity, productive sand layers are present throughout central portions of the valley. These sand zones are tapped by many

irrigation and municipal wells. Recharge to the deeper, regional system is limited, but generally has been sufficient for current rates of withdrawal. Thick lacustrine clays at the distal end of the valley likely inhibit upward (discharge) flow, limiting the amount of water that can flow through the system.

TABLE OF CONTENTS

Acknowledgements	ii
Executive Summary.....	iii
1. Introduction	1
1.1. Project Background	1
1.2. Report Scope.....	1
1.3. Previous Investigations.....	2
2. Description of Project Area.....	4
2.1. Project Area	4
2.2. Population.....	5
2.3. Climate.....	6
2.4. Land Use.....	8
2.5. Irrigation	8
3. Aquifer Description	13
3.1. Introduction.....	13
3.2. Geologic Setting	13
3.3. Stratigraphic Profile.....	14
3.4. Aquifer Description	21
3.5. Water Chemistry.....	23
3.6. Ground Water Flow Systems.....	24
3.7. Hydraulic Properties.....	25
3.8. Geothermal System.....	29
4. Dedicated TVHP Monitoring Wells.....	31
5. Ground Water Levels	36
5.1. Introduction.....	36
5.2. Mass Ground Water Level Measurements	36
5.2.1. Data Collection	38
5.2.2. Potentiometric Surface Maps.....	38
5.2.3. Seasonal Water Level Changes.....	41
5.3. Periodic Ground Water Level Monitoring.....	42
5.3.1. Well Network Description	42
5.3.2. Hydrographs.....	43
6. Aquifer Inflows and Outflows.....	46
6.1. Introduction.....	46
6.2. 1996 Water Budget.....	46
7. Treasure Valley Ground Water Flow Characteristics	49
8. References	54
Appendix A. Conversion Factors	59

Appendix B.	Aquifer Test Data.....	60
Appendix C.	Construction Details for Dedicated, Multi-Level Piezometers.....	83
Appendix D.	Construction and Measurement Details for Mass Measurement Wells.....	84
Appendix E.	Potentiometric Surface Maps.....	106
Appendix F.	Hydrographs.....	117
Appendix G.	Selected Hydrographs Showing Changes.....	139

LIST OF FIGURES

Figure 2-1: Map showing the Boise River basin, lower Boise River sub-basin, and Treasure Valley Hydrologic Project	4
Figure 2-2: Treasure Valley area.	5
Figure 2-3: Treasure Valley population growth for the period 1970-2000 (solid lines) and projected growth for the period 2000-2020 (dashed lines).	6
Figure 2-4: Monthly average temperatures.	6
Figure 2-5: Annual precipitation at the Boise Airport between 1940 and 2001.	7
Figure 2-6: Boise River basin precipitation at selected sites.	7
Figure 2-7: Treasure Valley land use.	8
Figure 2-8: Changes in Treasure Valley irrigated lands between 1938–1939 and 2000 (IDWR data).	9
Figure 2-9: Major and intermediate canals in the Treasure Valley (IDWR data).	10
Figure 2-10: Treasure Valley irrigation district boundaries (IDWR data).	11
Figure 2-11: Treasure Valley flood and sprinkler irrigation in 1994 (IDWR data).	12
Figure 3-1: Cross-section of the WSRP.	15
Figure 3-2: Upper Miocene basalt surface.	16
Figure 3-3: Surficial geology map.	20
Figure 3-4: Subdivisions of Idaho Group sediments.	22
Figure 3-5: Transmissivity estimates for wells completed between 0 and 300 feet below ground surface.	26
Figure 3-6: Transmissivity estimates for wells completed below 300 feet below ground surface.	27
Figure 3-7: Locations of selected single and multiple well aquifer tests.	28
Figure 4-1: TVHP monitoring well locations.	31
Figure 4-2: Hydrograph for TVHP #1.	32
Figure 4-3: Hydrograph for TVHP #2.	33
Figure 4-4: Hydrograph for TVHP #3.	34
Figure 4-5: Hydrograph for TVHP #4.	35
Figure 5-1: Potentiometric surface, spring 1996, shallow zone (240 wells).	39
Figure 5-2: Potentiometric surface, spring 1996, intermediate zone (49 wells).	39

Figure 5-3: Potentiometric surface, spring 1996, deep zone (45 wells).	40
Figure 5-4: Spring and fall 1996 change map.....	41
Figure 5-5: Locations of hydrograph wells.....	42
Figure 5-6: Locations of wells showing substantial water level changes.....	45
Figure E-1: Spring 1996, shallow zone (240 wells).	106
Figure E-2: Spring 1996, intermediate zone (49 wells).....	107
Figure E-3: Spring 1996, deep zone (45 wells).	107
Figure E-4: Fall 1996, shallow zone (235 wells).....	108
Figure E-5: Fall 1996, intermediate zone (49 wells).	108
Figure E-6: Fall 1996, deep zone (35 wells).....	109
Figure E-7: Spring 1998, shallow zone (259 wells).	109
Figure E-8: Spring 1998, intermediate zone (50 wells).....	110
Figure E-9: Spring 1998, deep zone (38 wells).	110
Figure E-10: Fall 1998, shallow zone (245 wells).....	111
Figure E-11: Fall 1998, intermediate zone (44 wells).	111
Figure E-12: Fall 1998, deep zone (29 wells).....	112
Figure E-13: Spring 2000, shallow zone (238 wells).	112
Figure E-14: Spring 2000, intermediate zone (42 wells).....	113
Figure E-15: Spring 2000, deep zone (27 wells).	113
Figure E-16: Fall 2000, shallow zone (16 wells).....	114
Figure E-17: Fall 2000, intermediate zone (34 wells).	114
Figure E-18: Fall 2000, deep zone (26 wells).....	115
Figure E-19: Fall 2001, shallow zone (212 wells).....	115
Figure E-20: Fall 2001, intermediate zone (35 wells).	116
Figure E-21: Fall 2001, deep zone (27 wells).....	116

LIST OF TABLES

Table 3-1: Geologic time during the Cenozoic and Mesozoic eras.....	14
Table 3-2: Stratigraphic names in the WSRP.	18
Table 4-1: Construction details for TVHP monitoring wells.....	32
Table 5-1: Numbers of wells measured during each of four mass water level measurements.....	37
Table 5-2: Model layer thicknesses.	37
Table 5-3: Approximate number of monitoring wells with increasing or decreasing water levels.	44
Table 6-1: Summary of recharge and discharge estimates contained in the 1996 water budget.....	47

1. INTRODUCTION

1.1. Project Background

The lower Boise River basin of southwestern Idaho (commonly referred to as the “Treasure Valley”) has experienced significant population growth, local ground water declines, and periodic drought conditions in the last two decades. This led to public concern about the status and future of water resources in the valley. The Treasure Valley Hydrologic Project (TVHP) was formed to address some of these issues and to provide a framework for future water management. The purpose of the TVHP was to develop a better understanding of ground water resources in the Treasure Valley and to evaluate changes in regional and local ground water conditions (Petrich, 2004c). The project included numerous components, including (1) water level measurements, (2) monitoring well construction, (3) water budget development, and (4) numerical modeling.

1.2. Report Scope

This report presents a summary of hydrologic conditions in the Treasure Valley aquifer system. The report includes descriptions of the (1) Treasure Valley area, (2) Treasure Valley aquifers, (3) multi-level ground water monitoring wells installed as part of the TVHP, (4) ground water levels based on well measurements, and (5) aquifer inflows and outflows. The report concludes with a description of ground water flow in Treasure Valley aquifers. This description of ground water flow forms the basis for a series of numerical simulations (Petrich, 2004a; 2004b).

This report draws, in part, from other reports and papers prepared as part of the TVHP. These include the following:

1. Geologic and Tectonic History of the Western Snake River Plain, Idaho and Oregon (Wood and Clemens, in press)
2. Water Budget for the Treasure Valley Aquifer System for the years 1996 and 2000 (Urban, 2004)
3. Simulation of Ground Water Flow in the Lower Boise River Basin (Petrich, 2004a)
4. Ground Water Recharge and Flow in the Regional Treasure Valley Aquifer System (Hutchings and Petrich, 2002a)
5. Influence of canal seepage on aquifer recharge near the New York Canal (Hutchings and Petrich, 2002b)

6. Domestic, Commercial, Municipal, and Industrial Water Demand Assessment and Forecast in Ada and Canyon Counties, Idaho (Cook et al., 2001)
7. Stratigraphic Studies of the Boise (Idaho) Aquifer System using Borehole Geophysical logs with Emphasis on Facies Identification of Sand Aquifers (Squires and Wood, 2001)
8. Seismic Reflection Project - UPRR 2000 Profile (Liberty and Wood, 2001)
9. Hydrogeology, Geochemistry, and Well Construction of the Treasure Valley Hydrologic Project Monitoring Well #1 (Dittus et al., 1999)
10. 1996 Water Budget for the Treasure Valley Aquifer System (Urban and Petrich, 1998)
11. New York Canal Geologic Cross Section, Seepage Gain/Loss Data, and Ground Water Hydrographs: Compilation and Findings (Carlson and Petrich, 1998)
12. Seismic Reflection Imaging of a Geothermal Aquifer in an Urban Setting (Liberty, 1998)
13. Structure Contour Map of the Top of the Mudstone Facies, Western Snake Supporting Data for Groundwater Conditions and Aquifer Testing of the Tenmile Ridge Area of South Boise, Ada County, Idaho (Dittus et al., 1998)
14. Ground Water Quality Characterization and Initial Trend Analysis for the Treasure Valley Shallow and Deep Hydrologic Subareas (Neely and Crockett, 1998)
15. Structure Contour Map of the Top of the Mudstone Facies, Western Snake River Plain, Idaho (Wood, 1997c)
16. Cross Section of the Treasure Valley in the Boise Area: Notes on the Geology of the Boise, Ontario, Parma, and Notus areas (Beukelman, 1997a; Beukelman, 1997b; Beukelman, 1997c; Beukelman, 1997d)
17. Preliminary Map of the Base of the Sedimentary Section of the Western Snake River Plain (Wood, 1996b)

1.3. Previous Investigations

Numerous previous investigations have focused on geology and hydrology in the Treasure Valley or Western Snake River Plain (WSRP). Lindgren (1898) provided early geologic descriptions of the Boise River Valley. Mabey (1982), Malde (1991), Wood and Anderson (1981), and Wood and Clemens (in press) described the geological setting. Othberg (1994), Othberg and Stanford (1992), Wood and Anderson (1981), Malde (1991), Clemens (1993), Wood (1994), and Wood and Clemens (in press) described valley stratigraphy. Several authors have described aquifer characteristics, including Dion (1972), Ralston and Chapman (1970), Wood and

Anderson (1981), Squires et al. (1992); and Wood and Clemens (in press). Previous ground water flow models were developed by Lindgren (1982), Newton (1991), and Brockway and Brockway (1999). The work conducted as part of the TVHP builds on these efforts.

2. DESCRIPTION OF PROJECT AREA

2.1. Project Area

The TVHP project area consists of (1) the lower Boise River sub-basin and (2) the area between the lower Boise River sub-basin and the Snake River (Figure 2-1). The lower Boise River sub-basin begins where the Boise River exits the mountains near Lucky Peak Reservoir. From Lucky Peak Dam, the lower Boise River flows about 64 (river) miles northwestward through the Treasure Valley to its confluence with the Snake River. The Boise River drains the central portion of the valley; the Snake River drains the southern portion of the valley. The project area (shown in red) extends south to the Snake River because ground water flows from some portions of the lower Boise River basin south toward the Snake River.

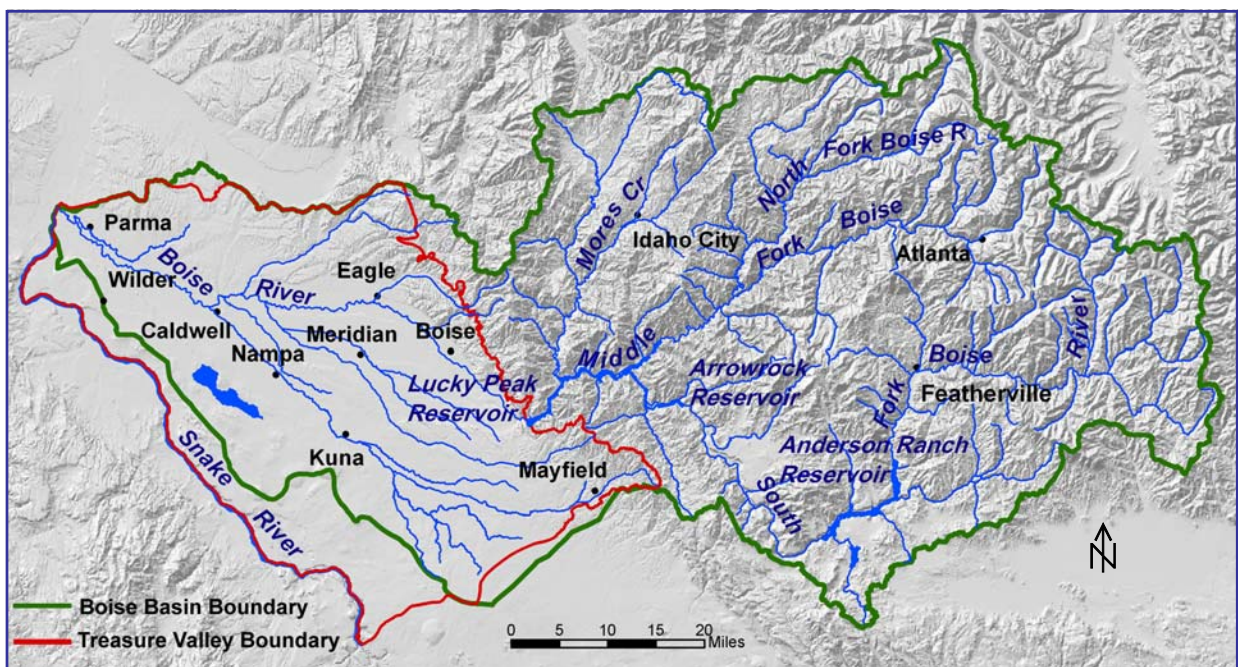

Figure 2-1: Map showing the Boise River basin, lower Boise River sub-basin, and Treasure Valley Hydrologic Project

The entire Boise River basin covers over 4,020 square miles in southwestern Idaho. Elevations in the basin range from a high of 10,174 feet above mean sea level (msl) to a low of 2,185 feet (msl) at the confluence of the Boise and Snake Rivers.

Most of the surface water in the lower Boise River basin originates in the upper Boise River basin. Much of the runoff from high elevation areas is stored in three reservoirs:

Anderson Ranch Reservoir, Arrowrock Reservoir, and Lucky Peak Reservoir (Figure 2-1). The northern portion of the basin drains a large portion of Idaho's south-central mountains. Major surface water bodies in the Treasure Valley include the Boise River, Lake Lowell, and the Snake River (Figure 2-2).

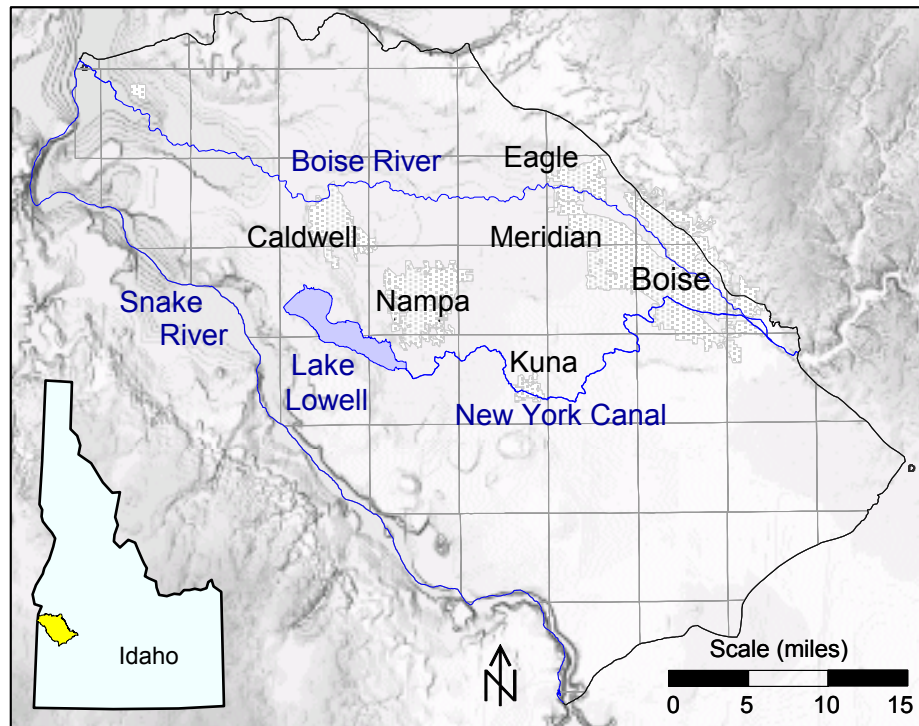

Figure 2-2: Treasure Valley area.

2.2. Population

The Treasure Valley was home to approximately 426,300 people in 2000¹, or about one-third of Idaho's population. Most of the Treasure Valley population is concentrated in the growing cities of Boise, Nampa, Caldwell, and Meridian, as well as a number of smaller communities (Figure 2-2).

Population growth in these areas for the period 1970–2000 is shown in Figure 2-3. The population is projected to grow to approximately 655,000 people by 2020², an increase of over 50% in 20 years.

¹ Source: U. S. Census data, presented by the Community Planning Association of Southwest Idaho (<http://www.compassidaho.org/demo/profiledemocharacteristics.pdf>).

² Source: Community Planning Association of Southwest Idaho (<http://compassidaho.org>)

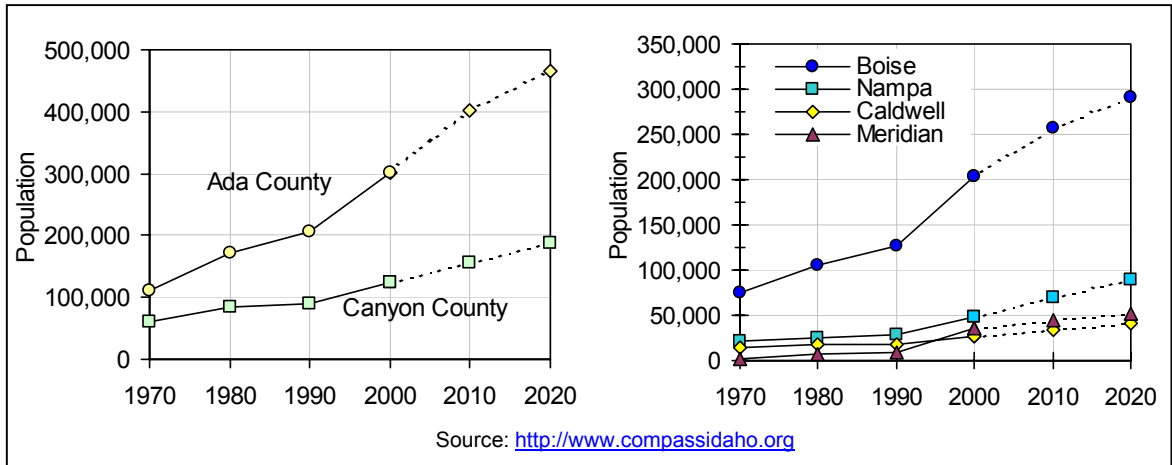
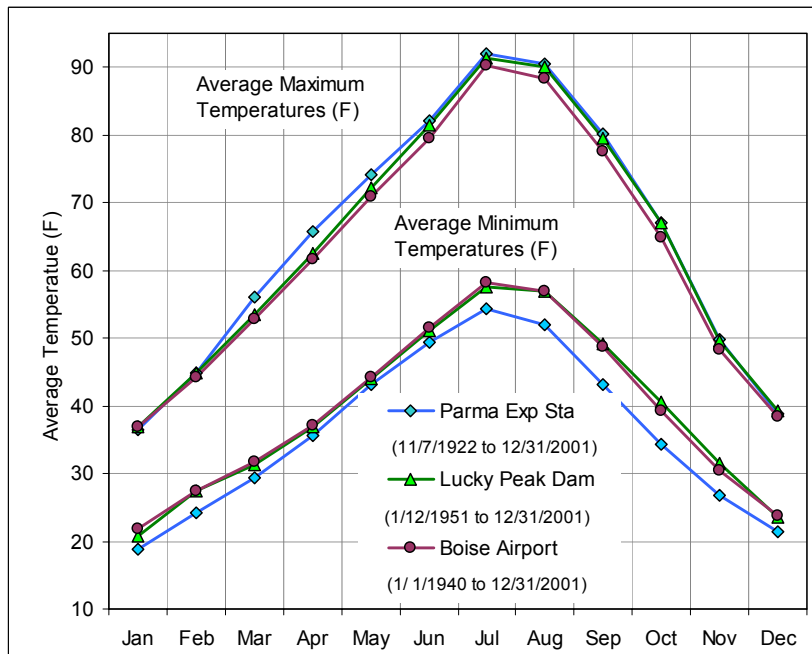

Figure 2-3: Treasure Valley population growth for the period 1970-2000 (solid lines) and projected growth for the period 2000-2020 (dashed lines).

2.3. Climate

The Treasure Valley has a temperate and arid to semi-arid climate. Average high temperatures range from about 90°F in summer to 36°F in winter (Figure 2-4); average low temperatures range from about 20°F in winter to about 56°F in summer. The average precipitation ranges from about 8 to 14 inches throughout most of the valley (Figure 2-5), most of which falls during the colder months (Figure 2-6).



Source: State Climate Services, Biological and Agricultural Engineering Department, University of Idaho.

Figure 2-4: Monthly average temperatures.

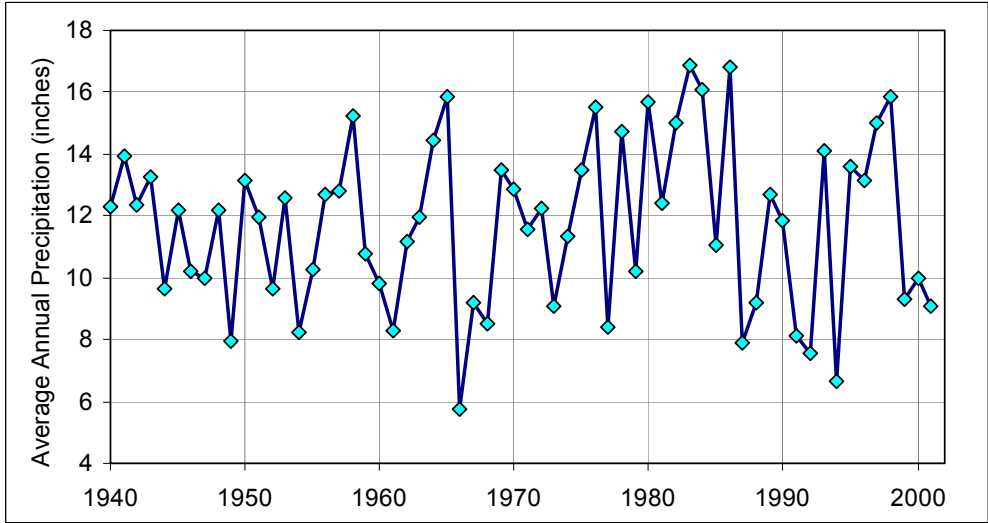

Source: State Climate Services, Biological and Agricultural Engineering Department, University of Idaho.

Figure 2-5: Annual precipitation at the Boise Airport between 1940 and 2001.

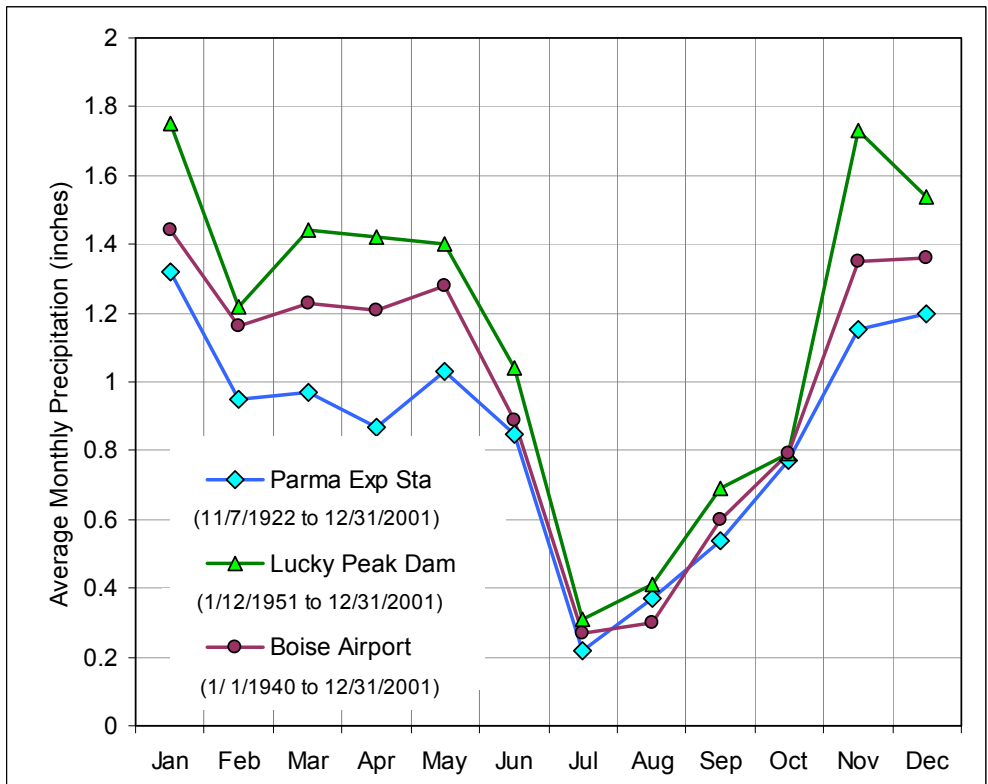

Source: State Climate Services, Biological and Agricultural Engineering Department, University of Idaho.

Figure 2-6: Boise River basin precipitation at selected sites.

2.4. Land Use

Approximately half of the land area in the Treasure Valley (Figure 2-7) is devoted to irrigated agriculture. Major crops grown in the Treasure Valley include alfalfa and alfalfa seed, sugar beets, wheat, beans, silage and seed corn, onions, and potatoes. Residential and commercial uses account for approximately 10% of the land use, and the remaining land is primarily open range and foothills.

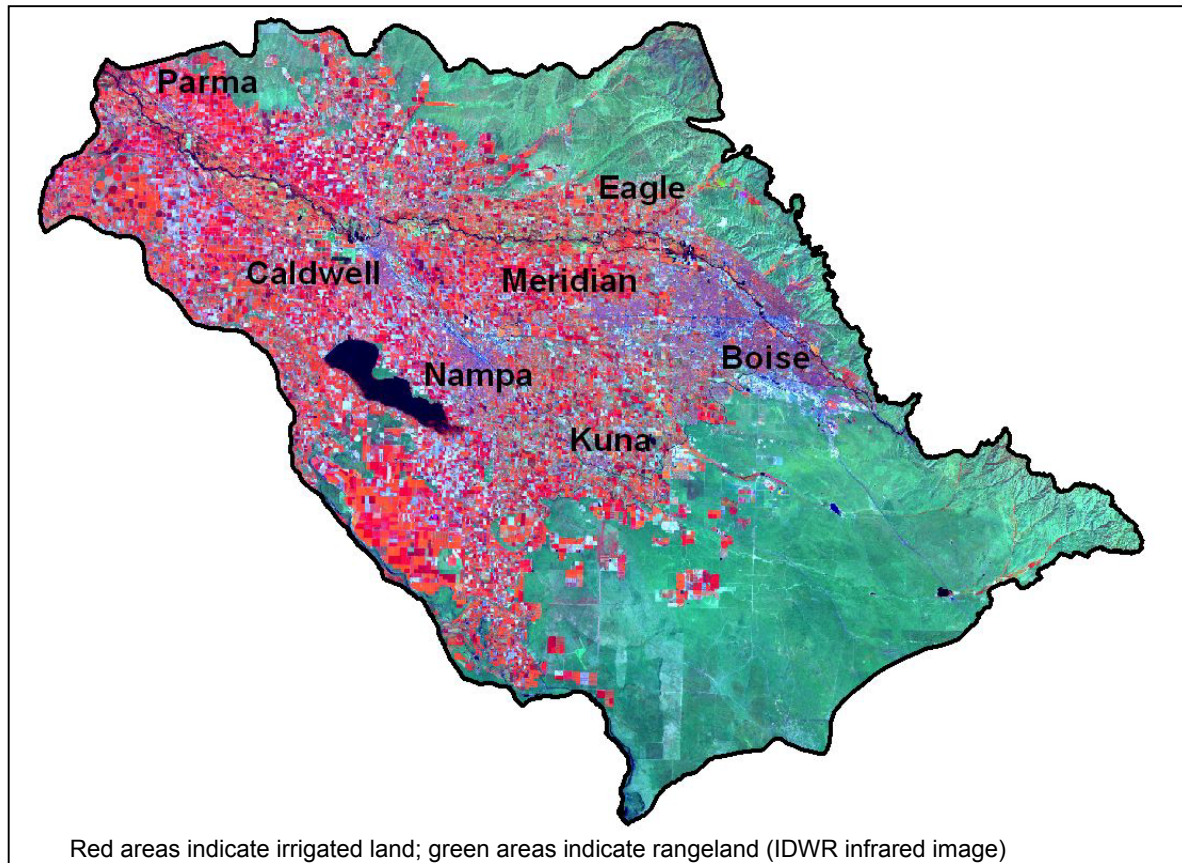

Figure 2-7: Treasure Valley land use.

2.5. Irrigation

Large-scale irrigation in the Treasure Valley began in the late 1800s, and by the 1930s, irrigated lands covered a large portion of the valley (Figure 2-8). The primary application method is flood irrigation, with water diverted from the Boise River. Expansion of irrigated land continued after 1939 (Figure 2-8). Some of the water for expanded irrigation was drawn from the Payette River (through the Black Canyon canal system), and some was obtained from ground water sources. In 1996, approximately 252,000 acres were irrigated with surface water (Urban and Petrich,

1998). An additional estimated 42,300 acres were irrigated with ground water. An increasing amount of irrigated land has been taken out of production in recent decades (Figure 2-8). Most of the loss of irrigated land between 1938–1939 and 2000 can be attributed to urban expansion.

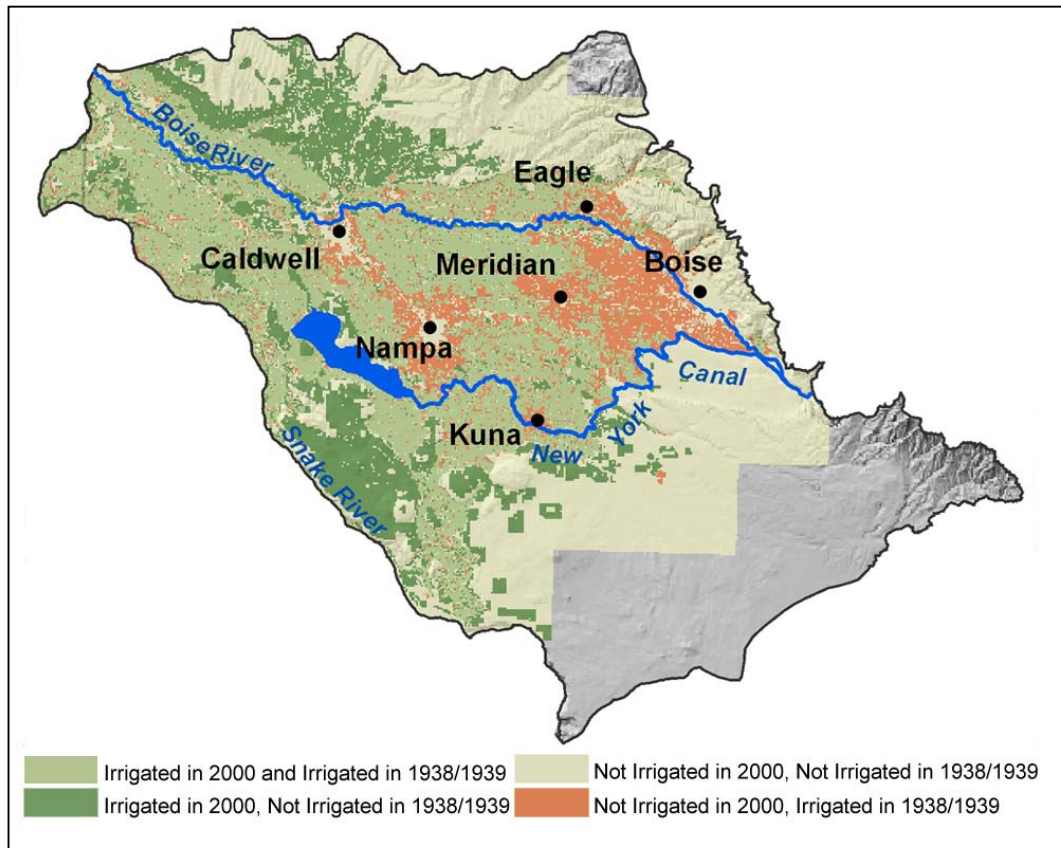

Figure 2-8: Changes in Treasure Valley irrigated lands between 1938–1939 and 2000 (IDWR data).

The region’s croplands are irrigated primarily with surface water through an extensive network of reservoirs and canals. The first canals were constructed in the 1860s; there are now over 1,100 miles of major and intermediate canals in the Treasure Valley (Figure 2-9)³. The majority of canals are owned and maintained by canal companies and irrigation districts (Figure 2-10). The Treasure Valley also has an extensive network of drains (and ditch companies that service the drains). These channels serve to drain water (often originating from irrigation practices) from low-lying areas. In some cases the drains are also canals, and shallow ground water discharging to drains is used for additional surface water irrigation.

³ Figure created by IDWR based on canals included in 1:100,000 scale topographic mapping.

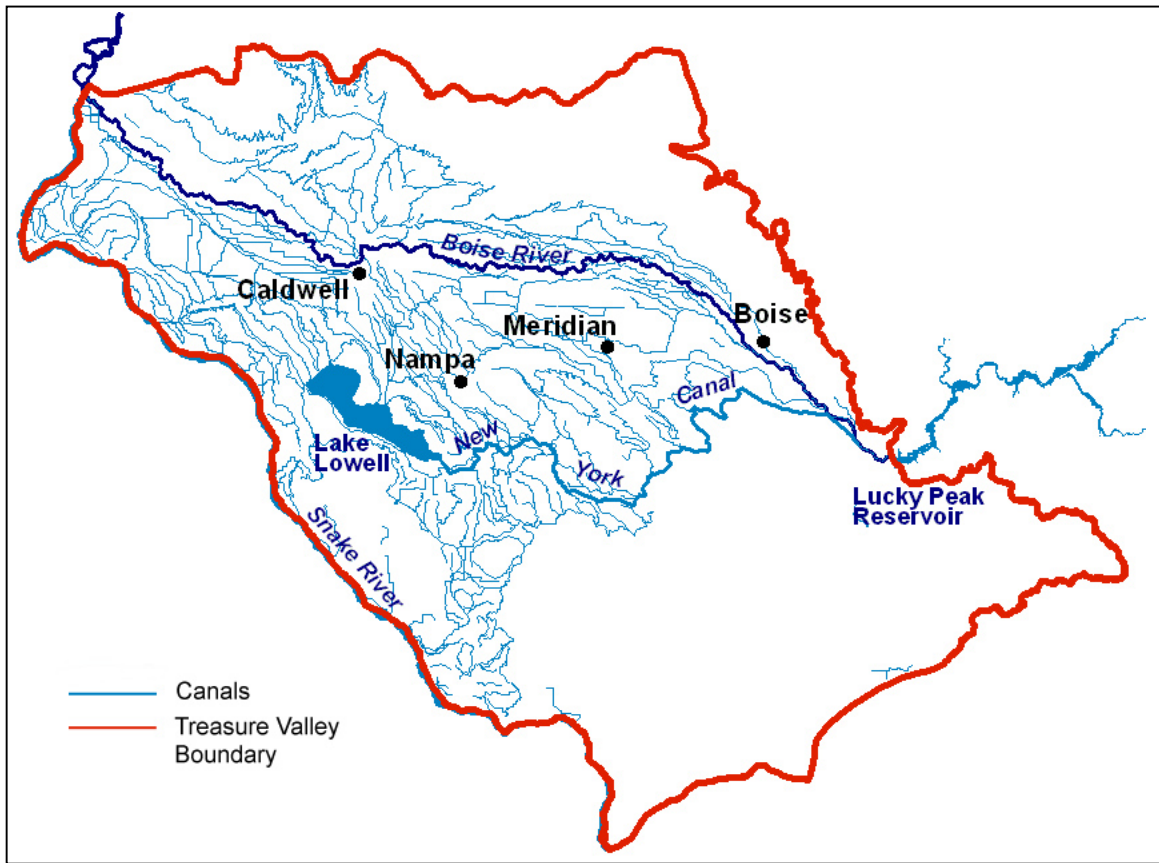

Figure 2-9: Major and intermediate canals in the Treasure Valley (IDWR data).

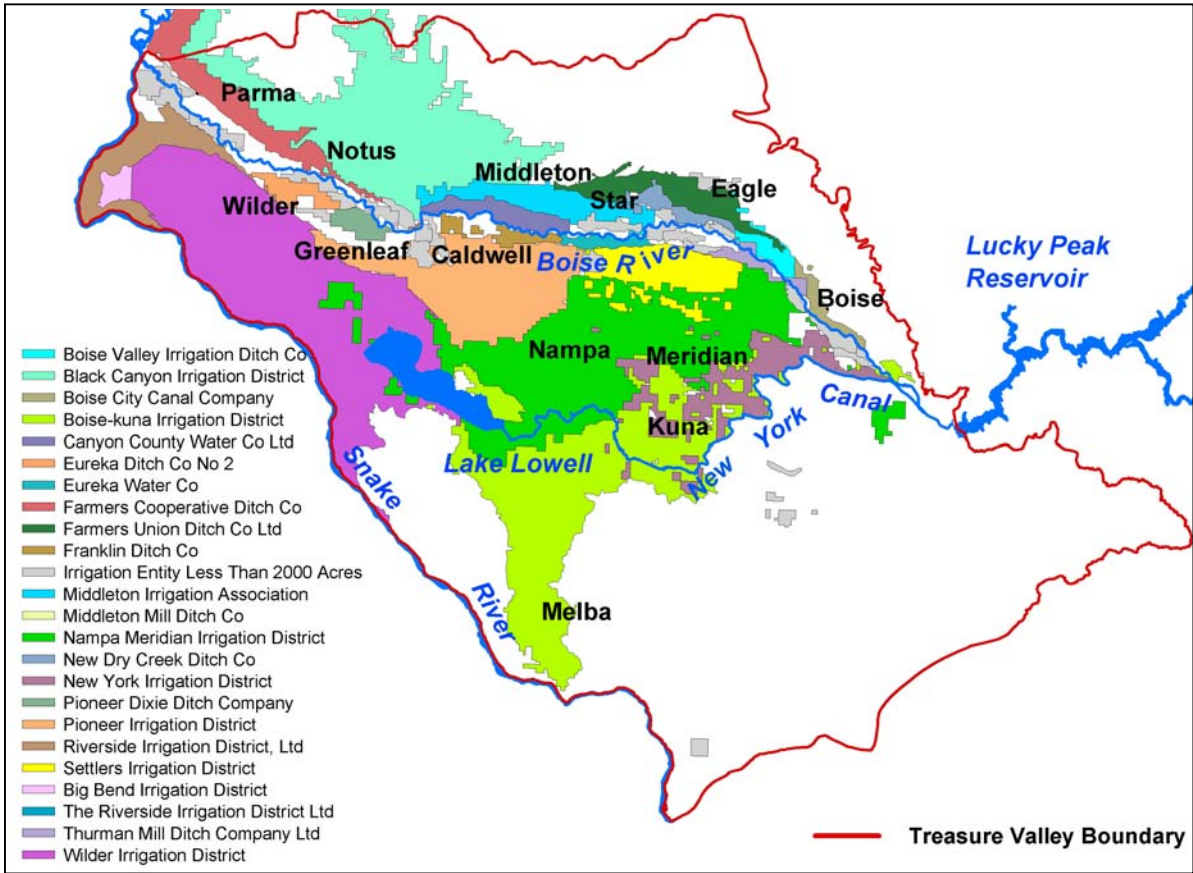

Figure 2-10: Treasure Valley irrigation district boundaries (IDWR data).

Of the estimated 252,000 acres irrigated in 1996 (Figure 2-11), approximately 101,000 acres was irrigated by sprinkler systems (Urban and Petrich, 1998). Of this total, approximately 42,000 acres (42%) are irrigated with ground water and 59,000 acres (58%) are irrigated with surface water. Ground water is used for irrigation in locations where surface water is unavailable or in times of surface water shortages. Irrigation wells were installed during the late 1920s and 1930s to provide supplemental irrigation during times of drought. Additional wells for primary and supplemental irrigation (and domestic uses) have been drilled during the last several decades.

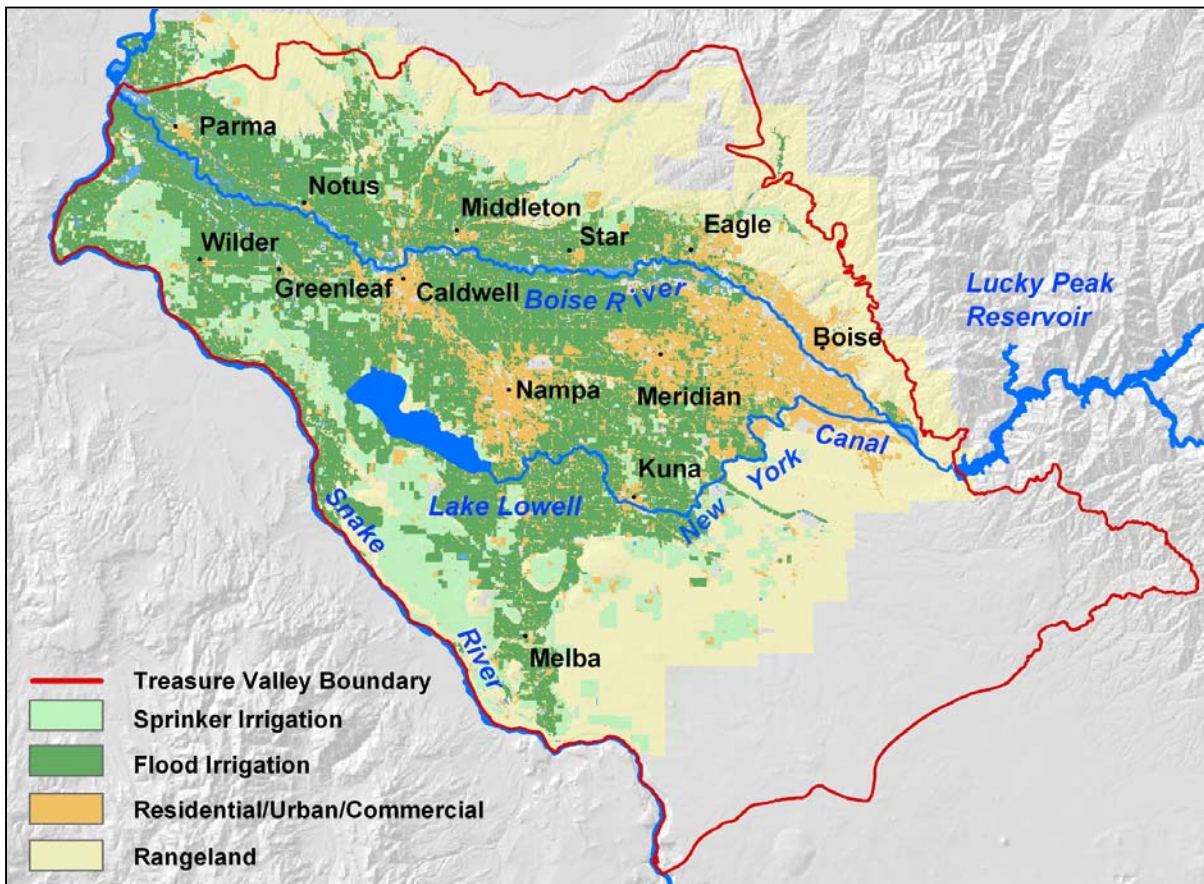

Figure 2-11: Treasure Valley flood and sprinkler irrigation in 1994 (IDWR data).

3. AQUIFER DESCRIPTION

3.1. Introduction

This section provides a description of Treasure Valley aquifer characteristics. Material for this section was drawn from geological investigations conducted prior to and as part of the TVHP. A description of flow characteristics, based on aquifer characteristics, hydraulic heads, hydraulic gradients, and estimates of inflows and outflows, is provided in Section 7.

3.2. Geologic Setting

The lower Boise River sub-basin (Treasure Valley) is located within the northwest-trending topographic depression known as the Western Snake River Plain (WSRP). The WSRP is a Neogene-aged (Table 3-1) continental rift basin (Wood and Clemens, in press), separating Cretaceous granitic mountains of west-central Idaho from the granitic/volcanic Owyhee mountains in southwestern Idaho. The WSRP now has the appearance of a northwest-trending graben associated with continental rifting (Mabey, 1982; Wood and Anderson, 1981). The WSRP extends from around Twin Falls, Idaho, northwestward to Vale, Oregon. The section of the WSRP containing the lower Boise River valley is about 30 miles wide (Figure 2-1 and Figure 2-2).

The WSRP is believed to have been formed by crustal extension (Malde, 1991, p.251). Malde suggests that the basin began forming as early as 17 million years ago (Ma), although Wood and Clemens (in press) suggest that the basin began forming about 11 Ma, with major faulting that occurred between 11 and 9 Ma (Wood and Clemens, in press). Miocene-aged (Table 3-1) rhyolite flows and domes are present along the margins of the WSRP. Rhyolite is present in outcrops in the Boise Foothills near Boise. Geothermal wells in the downtown Boise area draw water from two rhyolite zones separated by arkosic sand and granitic gravels. Deep wells north and west of Boise have not penetrated rhyolite (to the authors' knowledge); for example, the 14,100-foot-deep J.N. James well near Meridian did not encounter rhyolite (S. Wood, pers. comm., 2000). For this reason Wood and Clemens (in press) hypothesize that much of the plain may have been an upland during Miocene silicic volcanism.

The basin dropped, relative to surrounding highlands, by isostatic compensation (Malde, 1991) in response to thick accumulations of volcanics associated with rifting and deposition of overlying sediments (Mabey, 1982). Wood and Clemens (in press), Squires and Wood (2001), and others have described fluvial and lacustrine sediment deposition that occurred in the basin during this time (Section 3.3).

Era	Period	Epoch	Approximate Duration (Millions of Years)	Approximate beginning (Millions of Years Ago)	
Cenozoic	Quaternary	Holocene (Recent)	Approx. Last 10,000 years	10,000 years	
		Pleistocene	2	2	
	Tertiary	Neogene	Pliocene	3	5
			Miocene	18	23
		Paleogene	Oligocene	15	38
			Eocene	16	54
			Paleocene	11	65
Mesozoic	Cretaceous		71	136	
	Jurassic		54	190	
	Triassic		35	225	

Shading indicates ages represented in Treasure Valley geology.

Table 3-1: Geologic time during the Cenozoic and Mesozoic eras.

Volcanic activity returned to the WSRP during the late stages of Lake Idaho (see Section 3.3) about 5.5 Ma (Wood and Clemens, in press). Lava erupted from a line or series of volcanic vents referred to as the Kuna–Mountain Home volcanic rift. These Quaternary basalt flows, assigned to the upper Snake River Group (Malde, 1991, p.266; Malde and Powers, 1962), flowed across portions of the ancestral Snake River Valley in an area that is now south of the Boise River (Malde, 1991). The Snake River then changed course, incising at its present location along the southern margin of the basalt flows. More recent eruptions (from Kuna Butte and other local sources along the rift) spilled lava into the Snake River Canyon south of Melba. The Snake River has since incised into this basalt (Malde, 1991, p.267).

3.3. Stratigraphic Profile

The general stratigraphy of the WSRP consists of interbedded layers of sand, silt, and clay overlying Miocene tuffaceous sediments and basalt flows (Figure 3-2). The sediments, ranging up to 6,000 feet in thickness in some locations, distinguish the WSRP from the Eastern Snake River Plain (ESRP), which is primarily Quaternary basalt in its upper section (Wood and Anderson, 1981, p.9).

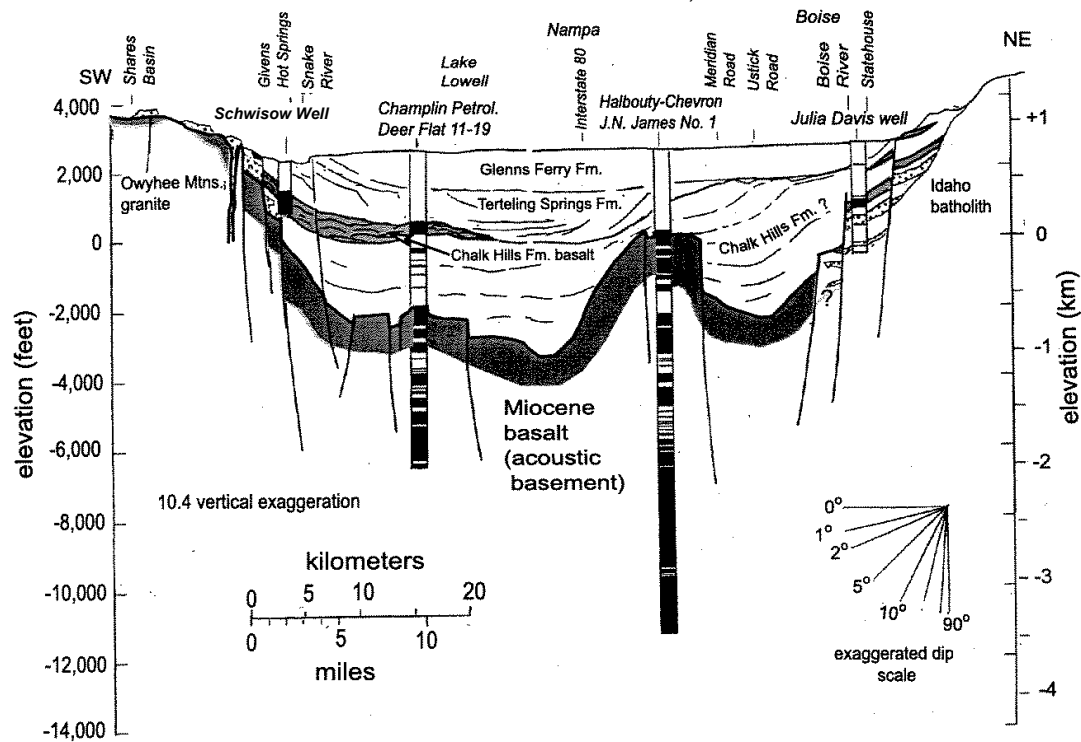

From Wood and Clemens (in press).

Figure 3-1: Cross-section of the WSRP.

The Miocene-aged tuffaceous basalt rests unconformably on granitic rocks of the Idaho Batholith, on late Miocene rhyolite, and/or on basalt of the Miocene Columbia River Group (Wood and Clemens, in press). The basalt assemblage is several hundred feet thick in the Boise area and forms the basement for sediments comprising the Treasure Valley aquifers.

The upper surface of the Miocene basalt forms a highly irregular surface (Figure 3-2), intersected by numerous northwest-southeast trending faults (Figure 3-3). The basalt surface was interpreted by Wood (1996b) based on well data, deep seismic reflection data, subsurface investigations in east Boise (Squires et al., 1992), and shallow seismic data (Liberty, 1996a; Liberty, 1996b).

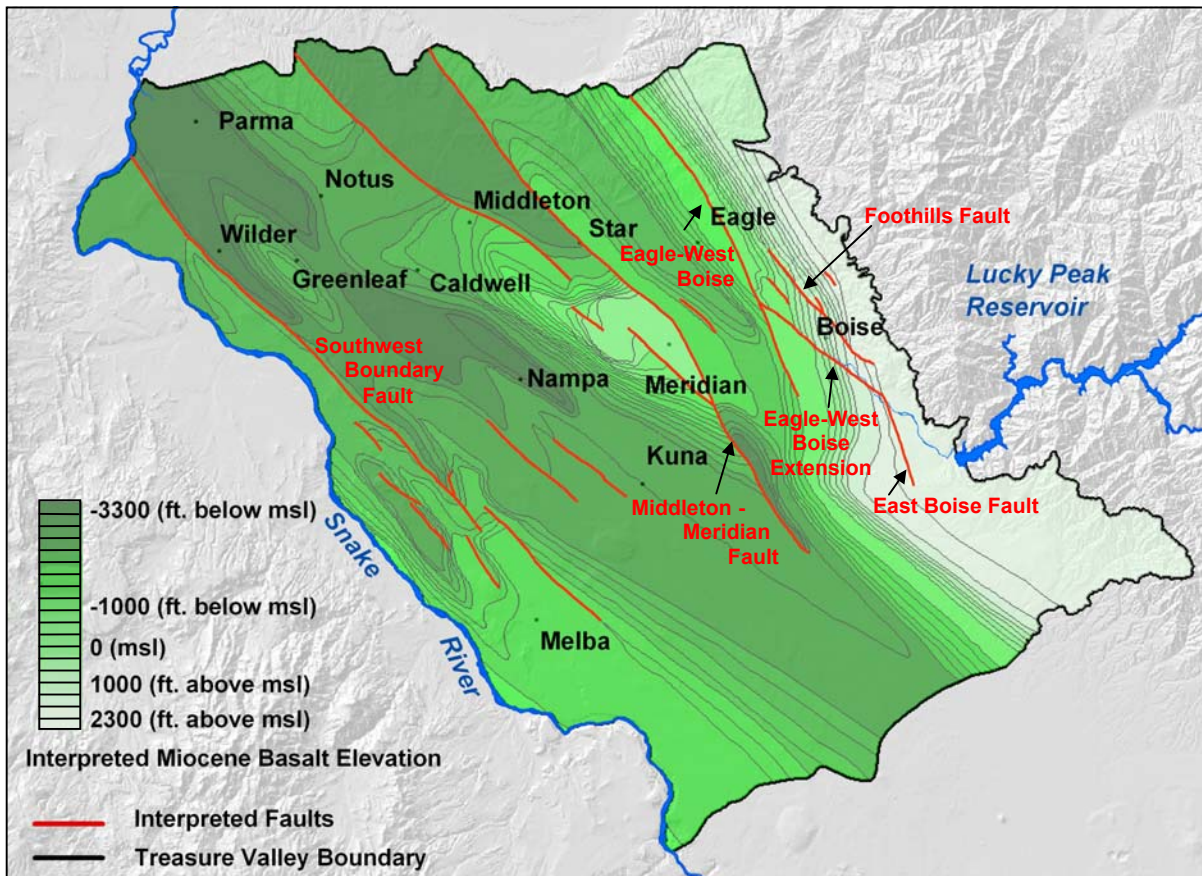

Based on Wood (1997b) and Squires et al. (1992).

Figure 3-2: Upper Miocene basalt surface.

Faulting has been described by numerous authors (Barrash and Dougherty, 1995; Liberty, 1996a; Liberty, 1996b; Liberty, 1998; Liberty and Wood, 2001; Malde, 1991, p. 259; Othberg and Stanford, 1992; Squires et al., 1993; Squires et al., 1992; Wood, 1994; Wood, 1996b; Wood and Anderson, 1981; Wood and Clemens, in press) on the basis of surface geomorphology, stratigraphic correlations, and seismic reflection surveys and associated interpretations. Displacement along these faults ranges from feet to hundreds of feet. Cumulative fault offsets (up to several hundred feet of displacement) and basinward downwarping account for much of the basin structural relief (Figure 3-3). The East Boise Fault truncates the Boise Fan sediments with 400 to 600 feet of displacement along the fault (Squires et al., 1992). Additional faults are illustrated in Othberg and Stanford (1992).

Other major faults include the Eagle–West Boise Fault, Foothills Fault, Middleton–Meridian Fault, Lake Lowell Fault, and Southwest Boundary Fault (Wood, 1996b). The West Boise–Eagle Fault has about 800 feet of displacement near Chinden Boulevard just west of the Boise Fairgrounds and has been recognized by apparent stratigraphic offsets in wells between Dry Creek and Eagle along Highway 55.

Transmissive sands appear to be rare below a depth of 300 to 400 feet northeast of the fault (R. Dittus, pers. comm., 2003)⁴; productive sands are present at deeper depths southeast of the fault. The clay northeast of the fault is considered to be part of the mudstone facies of the Terteling Springs Formation (Burnham and Wood, 1992). The Foothills Fault also is a recognizable feature along the Boise Foothills near Boise (with an offset of greater than 500 feet in the Boise vicinity), although seismic data in the lower Stewart Gulch area (Wood, written comm., 2003) do not show large displacement along the foothills margin. The Middleton–Meridian Fault (actually seen as four faults distributed over a 1.5-mile-wide area in the Chevron seismic line) has an approximate offset of 1,200 feet (Wood, 1996b). The Lake Lowell Fault is mapped between the southern edge of Lake Lowell and Wilder and has a displacement of about 400 feet. Finally, Wood (1996b) describes about 4,000 feet of subsurface structural relief over a 5 mile area southwest of Marsing, although detailed subsurface studies have not been done in this part of the valley.

A thick sequence of sediments overlies the Miocene volcanics (Figure 3-1). These sediments are categorized into two groups: the older and deeper Idaho Group and younger Snake River Group (Table 3-2). Idaho Group sediments represent a thick series of predominantly lacustrine sediments that include the Chalk Hills, Terteling Springs, and Glens Ferry Formations (Kimmel, 1982; Wood and Clemens, in press). In general, these sediments range to several thousand feet in thickness and grade finer with depth.

The Idaho Group sediments originated from large lakes in the WSRP during the late Miocene and Pliocene epochs. The base of the sedimentary sequence consists of interbedded arkose, mudstone, and volcanic ash, considered part of the Chalk Hills Formation (Kimmel, 1982). Sediments within the bottom 300 feet are generally coarse sand and pebble gravel originating from the Idaho Batholith and other older volcanics, grading upward into tuffaceous muds, clays, and ash beds (Wood and Clemens, in press). The Chalk Hills sediments are faulted and tilted, dipping 4 to 12 degrees basinward, compared to overlying lacustrine sediments that dip less than 4 degrees (Wood and Clemens, in press). In some areas, an unconformity associated (in part) with the occurrence of gravels separates Chalk Hills sediments from overlying sediments (Squires and Wood, 2001; Wood and Clemens, in press).

A transgressive sequence followed the draining of the Chalk Hills Lake, beginning about 5.5 Ma, resulting in a vast lake referred to as Lake Idaho (Wood and Clemens, in press). At its maximum extent, Lake Idaho reached an elevation of about 3,600 feet (msl) in the Boise Foothills. Most of the exposed sediments in the Boise Foothills appear to have been deposited during this transgressive sequence. These sediments,

⁴ The TVHP #1 well (Figure 4-2) was drilled on the northeast side of this fault to a depth of 1,005 feet, with the lower 600 feet in dominantly clay materials (Dittus et al., 1999); see Section 4.

mapped as the Terteling Springs Formation (Burnham and Wood, 1992; Wood and Clemens, in press), include shoreline sand deposits with oolitic sand lenses, small deltaic deposits, and a mudstone facies associated with lacustrine deposition basinward. The Terteling Springs Formation is indicated by a 400-foot-thick section of near-shore sediments marked by oolitic lenses and extends to an elevation of up to 3,200 feet (msl) in the Boise Foothills (Squires and Wood, 2001).

Time	Lithostratigraphic Units		Group
Quaternary	Alluvium		Snake River Group
	Gravel of the Boise Terrace		
	Gravel of the Whitney Terrace		
	Gravel of the Sunrise Terrace		
	Basalt of the Gowen Terrace (0.572 ± 0.210 Ma)		
	Gravel of the Gowen Terrace		
	Basalt of the Fivemile Creek (0.974 ± 0.130 Ma)		
	Gravel of the Fivemile Creek		
~1.8 Ma			
Pliocene	Tenmile Gravel		Idaho Group
	East Boise alluvial fan deposits		
	Pierce Gulch Sand	Glenns Ferry Formation	
~5.0 Ma			
Upper Miocene	Terteling Springs Sand Facies	Basalt of Aldape Park (9.4 ± 0.6 Ma)	Idaho Group
	Mudstone Facies		
	Boise Foothill Volcanic Assemblage Basalt of Pickett Pin Canyon Volcaniclastic sediments and tuffs and Barber rhyolite ash Lower basalt flow rocks		Idavada Group
	Rhyolite of Quarry View Park (11.8 ± 0.6 Ma)		
	Rhyolite of Table Rock Road		
Rhyolite of Cottonwood Creek (11.3 ± 0.6 Ma)			
~38 Ma			
Mesozoic & Eocene	Granitic Rocks		Idaho Batholith
Adapted from Squires and Wood (2001).			

Table 3-2: Stratigraphic names in the WSRP.

Malde and Powers (1962) suggested that the lowest occurrence of oolitic shoreline sands marks the base of the Glenns Ferry Formation, which covered a large area from the Snake River at Glenns Ferry to Homedale. More recently, Burnham and Wood (1992) and Wood and Clemens (in press) have defined the lower portion of these sediments as the Terteling Springs Formation.

Wood and Clemens (in press) hypothesize that Lake Idaho began to recede about 4 Ma, with the outlet downcutting at a rate of approximately 400 feet per million years. Sediments (originally eroded from uplands and deposited at the basin margins) were further eroded as Lake Idaho water levels dropped. These sediments contributed to filling the receding lake, forming interbedded sand and mud sequences and extensive lacustrine delta systems. Along the Boise Foothills, these sediments are represented by a 200-foot-thick coarse sand unit (Pierce Park Sand) with Gilbert-type foreset bedding. The Pierce Park Sand correlates basinward with the Glens Ferry Formation (Squires et al., 1993; Wood and Clemens, in press), which overlies the Terteling Springs facies. These sediments were spread basinward as the lake system receded from the valley during the Lake Idaho regression (E. Squires, pers. comm., 2003).

Within the general transgressive (Terteling Springs deposits) and regressive (Pierce Park–Glens Ferry deposits) sequence, there is evidence of rising and lowering lake levels. The occurrence of gravel layers in the valley several miles from the basin margins within a general lacustrine sediment sequence is evidence of fluvial deposition, indicating multiple episodes of lowering and raising of lake levels within the transgressive-regressive sequence (Squires and Wood, 2001).

The top of the upper Idaho Group is marked in several parts of the Treasure Valley by a widespread fluvial gravel deposit known as the Tenmile Gravel. Tenmile Gravels contain rounded granitic rocks and felsic porphyries originating from the Idaho Batholith to the north and northeast. The Tenmile Gravels may range up to several hundred feet in thickness along the Tenmile Ridge south of Boise but are less than 50 feet thick in the Nampa-Caldwell area (Wood and Anderson, 1981).

Wood (1994) identified a buried lacustrine delta within the Idaho Group sediments in the Nampa-Caldwell area. The location of the delta in the WSRP suggests that the eastern part of the Boise River basin was delta plain and flood plain at the time of deposition, while the western part was a slack-water (e.g., lake) environment. The delta probably prograded northwestward into a lake basin about 850 feet deep based on high-resolution seismic reflection data and resistivity log interpretations. The delta-plain and delta-front sediments were shown to be mostly fine-grained, well-sorted sand with thin layers of mud (Wood, 1994). The northwest trend of the delta indicates a sediment source to the southeast, such as where the Snake River flows today (Wood, 1994).

The uppermost sediments and basalt covering much of the project area (Figure 3-3) belong to the Pleistocene-age Snake River Group (Othberg and Stanford, 1992). The Snake River Group sediments, consisting primarily of coarse-grained sand and gravels, include Quaternary alluvium, a series of Quaternary terrace gravels and sands, and Pleistocene basalt flows (Wood and Anderson, 1981). The basalt flows cover primarily the southern portion of the project area (Figure 3-3).

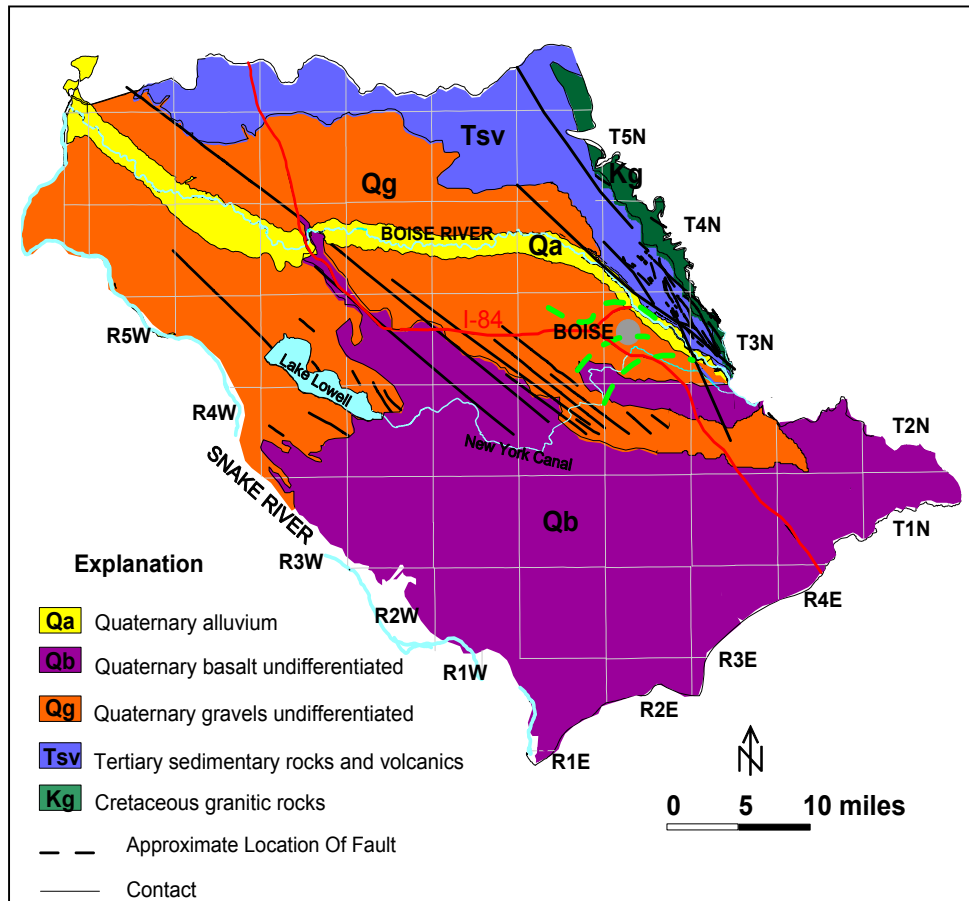

From Othberg and Stanford (1992)

Figure 3-3: Surficial geology map.

Several stratigraphic cross-sections were drawn by Beukelman (1997a; 1997b; 1997c; 1997d), Wood (1996a), and Squires and Wood (2001) as part of the TVHP. The cross-sections were based on drillers' logs, geophysical logs, geologic outcrops, and seismic data. Surficial deposits were noted as modern flood plain deposits, Bonneville Flood slackwater fine sediments, Pleistocene gravels, and older tertiary-age sediments.

A transition from brown to underlying blue or gray sediments is noted in many drillers' reports and in the various cross-sections. The color transition is observed throughout central and western portions of the valley (Beukelman, 1997b; Beukelman, 1997c; Beukelman, 1997d; Squires and Wood, 2001), as far west as Parma and Ontario and as far east as Boise (Beukelman, 1997a; Squires et al., 1992). The blue-gray sediments are not found in the upper 1,100 feet of alluvial fan sediments east of Boise (Squires et al., 1992). The blue-gray sediments generally consist of clay and/or silt but also may include interbedded sand or even pea gravels. The upper surface of these sediments, frequently referred to as the "blue clay," can be found at depths ranging from tens of feet to over 800 feet below ground surface.

The origin of the contact between brown and blue-gray sediments is not well understood. The bluish color probably reflects chemically-reducing conditions associated with an oxygen-poor environment. Some of the color may be associated with depositional environment, especially when lacustrine sediments become buried under new deposition. Some of the color may be associated with post depositional conditions, as evidenced by gravels and coarse sands within bluish horizons. Local elevation variations in bluish sediments may reflect erosion of the blue-gray sediments, exposure to oxygen, and/or structural movement.

The use of color changes to identify depositional environments can be misleading. Despite the presence of blue-gray sediments throughout much of the valley, the color-change contact does not appear to represent individual areally-extensive strata. Bluish-colored sediments may change color if exposed to oxygen (or oxygen-rich ground water). Thus, the transition from brown to blue-gray sediments probably reflects a combination of deposition and post-depositional conditions and therefore, is not necessarily indicative of current ground water flow conditions.

Multiple layers of clay are found within the Idaho Group sediments. These clay layers, in aggregate, form aquitards separating shallow aquifers from deeper zones. Although the clay layers are often of substantial thickness, individual clay units are not necessarily continuous over large portions of the project area.

3.4. Aquifer Description

Treasure Valley aquifers also have been described in terms of subdivisions based on general material properties and location within the valley (Squires et al., 1992). This section provides a general description of primary aquifers on the basis of sedimentary characteristics.

The sediments included in these subdivisions may span multiple formations or geologic groups (Section 3.3). For instance, some of the East Boise alluvial fan sediments may be contemporaneous to the upper Chalk Hills Formation (Wood and Clemens, in press); lacustrine sediments in the central portion of the valley may belong to the Chalk Hills, Terteling Springs, and/or Glens Ferry Formations. Distinctions between the specific geologic formations may not necessarily indicate differences in ground water flow characteristics. For instance, lacustrine sediments in the central portion of the valley may have similar ground water flow characteristics, regardless of whether they belong to the Chalk Hills Formation or the Terteling Springs mud facies.

Thus, the Treasure Valley aquifer system consists of a series of sedimentary aquifers within the Idaho Group and Snake River Group sediments. Squires et al. (1992) interpreted five subdivisions (Figure 3-4) within the Idaho Group sediments in the Boise area using geophysical logs, well logs, and aquifer tests. The five subdivisions

are the (1) Boise Fan Sediments, (2) Fan-to-Lake Transition Sediments, (3) Central Boise Lacustrine Sediments, (4) Deep Lacustrine Sands and Alluvial Lake Margin Sands of west Boise, and (5) Lake Margin Sands of northeast Boise.

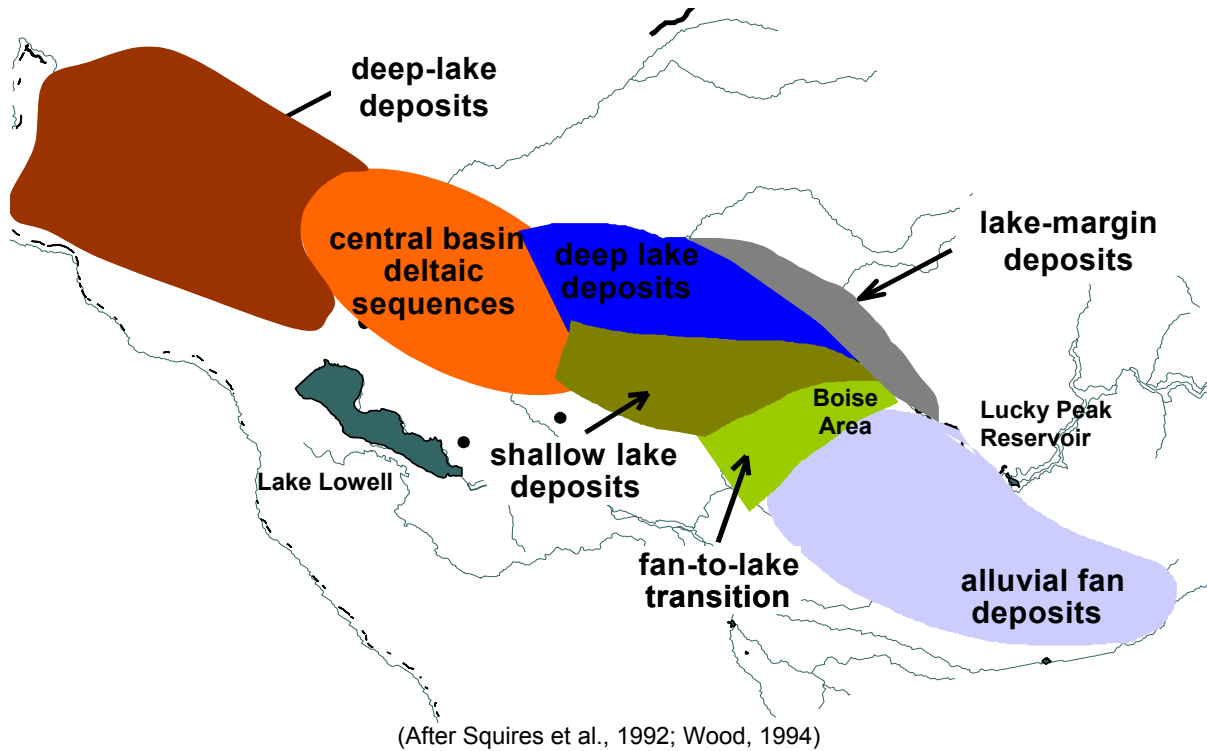

Figure 3-4: Subdivisions of Idaho Group sediments.

The Boise Fan (Squires et al., 1992) covers a large, highly heterogeneous deposit of gravels, sands, and silts, beginning near Lucky Peak Dam and extending about 6 miles to the west-northwest. Predominantly silty sands, the Boise Fan sediments also contain numerous gravel lenses and a few silt lenses. Fan-to-Lake Transition sediments were described as clays and sands of alternating brown and blue colors, indicating interfingered oxidized and reduced materials, respectively. Squires et al. (1992) described the Central Boise Lacustrine sediments as sand, silt, and clay units bearing lacustrine features (e.g., oolites, fine grain sizes). Sediments underlying an area of west Boise were described as deep lacustrine sands and alluvial lake margin sands. Wells in this area encountered 500 feet of nearly horizontal medium- to coarse-grained sands interbedded with silts, sands, and clays, underlain by 500 to 1,000 feet of fine-grained sand layers within thick layers of clay and silt. Seismic data indicated a westerly dip in the lower section of 3 to 7 degrees and 2 to 3 degrees in the upper materials. Finally, Squires et al. (1992) interpreted lake margin sediments containing sands, gravels, and occasional silty zones in the area underlying northeast Boise. The sediments were interpreted as lake margin sediments on the basis of the well-sorted

nature of the sand layers, interbedded fluvial deposits, and their stratigraphic location with respect to adjacent geologic outcroppings of the Boise Foothills.

Wood and Anderson (1981) first suggested that the Glens Ferry sediments rest on a geological unconformity within the Idaho Group. The lower sediments dip basinward approximately 4 to 7 degrees. The buried unconformity lies 350 to 400 feet beneath central and east Boise and 400 to 500 feet deep in west Boise (Squires et al., 1992). Additional fluvial deposits have been noted within lacustrine sequences (Squires and Wood, 2001), indicating multiple episodes of rising and lowering lake levels.

Sequences of interbedded sand, silt, and clay, such as the upper portion of the Glens Ferry Formation of the upper Idaho Group in the Nampa–Caldwell area, are the major water-producing aquifers in a large part of Canyon County (Anderson and Wood, 1981).

3.5. Water Chemistry

Despite regional geologic complexity, geochemical analyses conducted as part of the TVHP (Hutchings and Petrich, 2002a) show predictable relationships between ground water chemistry and the unique depositional environments of the principal aquifers. The analyses indicated (1) a strong relationship between concentrations of dissolved constituents and positionally-defined aquifer units, (2) apparent geochemical evolution along the valley axis, and (3) a general east-to-west increase of ground water residence times.

Geochemical evolution of Treasure Valley ground water appears to be influenced by a solution of both carbonate and silicate minerals. Ground water near the northeastern basin margin has experienced little chemical interaction with aquifer minerals; ground water beyond the northeastern basin margin has experienced substantial interaction with aquifer minerals.

Concentrations of major ions and other dissolved constituents vary consistently with depth among aquifer zones. Specific conductance (and by inference, concentrations of total dissolved solids) is often greater in shallow alluvial aquifers than in some deeper zones. This finding indicates that water in these deeper zones did not enter the ground water regime through the carbon-rich sediments found in Treasure Valley soils.

Residence times of Treasure Valley ground water generally increase with depth and with distance along a regional east-to-west trending flow path (Hutchings and Petrich, 2002a; Hutchings and Petrich, 2002b). Residence times range from years to hundreds of years in shallow aquifers and thousands to tens of thousands of years in deeper, regional aquifers.

Residence times in the shallow system are bracketed, in part, based on tritium concentrations remaining from nuclear testing during the 1950s and 1960s. Tritium is present in shallow aquifers, such as those underlying the New York Canal (Hutchings and Petrich, 2002b). Tritium is virtually non-existent in deeper, regional ground waters, except where well construction has allowed inter-aquifer mixing. This finding indicates that ground water in deeper aquifers entered the flow regime prior to atmospheric nuclear testing during the 1950s and 1960s.

The youngest waters in the deeper, regional flow system entered the subsurface a few thousand years ago and are found along the eastern and northeastern boundary of the basin, adjacent to the Boise Foothills. The oldest waters in the regional flow system entered the subsurface between 20,000 and 40,000 years ago and are now found in the western reaches of the basin near the Snake River. Ground water in the deep deltaic aquifers beneath Boise entered the subsurface between 10,000 and 20,000 years ago.

From the ground water chemistry analyses it becomes clear that contemporary seepage from surface water in the central portion of the valley and/or irrigation water is not the primary source of recharge for most deeper, regional aquifers. Fractured granite aquifers of the Idaho Batholith, surface water in the far eastern portion of the valley, and tributary sedimentary aquifers (underflow) are the most likely sources of recharge to the regional flow system. A conceptual model consisting of (1) recharge in alluvial sediments in southeast Boise and at the base of the mountain front north of Boise, (2) movement of ground water from the recharge areas into the deeper Boise area fluvio-lacustrine aquifers, and (3) movement of ground water from the Boise area aquifers into regional deep-lake aquifers of Nampa and Caldwell is consistent with these chemistry data.

3.6. Ground Water Flow Systems

Ground water for municipal, industrial, rural domestic, and irrigation uses in the Treasure Valley is drawn from Snake River Group and Idaho Group aquifers. Many domestic wells draw water from shallow aquifers, such as those in the Snake River Group deposits. Larger production wells (for municipal and agricultural uses) generally draw water from the deeper Idaho Group sediments. Flow systems providing water to these wells can be markedly different. Distinguishing between shallow and regional ground water flow systems is important for understanding ground water flow characteristics and managing ground water resources.

Local flow systems in shallow aquifers are recharged by infiltration associated with precipitation, irrigation, and channel (e.g., streams or canals) losses. These local flow systems often discharge to local drains or streams. The time from recharge to discharge in shallow flow systems probably ranges from days to hundreds of years. In contrast, regional ground water flow systems extend much deeper than local flow

systems. The Treasure Valley regional flow system begins with downward movement in coarse-grained alluvial fan sediments in the eastern portion of the valley. Some water also enters the regional flow system as underflow from the Boise Foothills in the northeastern part of the valley. The regional flow system is thought to discharge primarily to the Boise and Snake Rivers in the western and southwestern parts of the valley. Residence times (Section 3.5) for some of the water in the regional flow system were estimated to be greater than 20,000 years (Hutchings and Petrich, 2002a).

3.7. Hydraulic Properties⁵

Numerous hydraulic parameter value estimates have been made for Treasure Valley aquifers. Most parameter estimates have been made on the basis of single-well tests. Water production wells are frequently pumped to estimate well yield and specific capacity. Very approximate estimates of transmissivity can sometimes be obtained with specific capacity data (Driscoll, 1986). Permeability estimates have also been made under laboratory conditions at some locations in conjunction with landfill construction (e.g., Seaman's Gulch, Clay Butte, and Pickles Butte). In addition, a few large-scale, multiple-well tests have been conducted in the Treasure Valley.

Specific capacity data obtained from well drillers' reports were used to develop plots of aquifer transmissivity values. These plots, however, should only be viewed on a qualitative basis because of a high degree of uncertainty associated with these data. The uncertainty is high because of variability in test duration, pumping rate, well efficiency, differences in well construction (e.g., different lengths of open intervals), degree of aquifer penetration, and measurement accuracy.

Well pump test data for 197 wells within the valley formed the basis for the specific capacity plots. The specific capacity data were compiled from drillers' report information contained in the IDWR Well_Log database⁶. Specific capacity data were divided into two depth zone categories: a zone from 0 to 300 feet below ground surface and a zone greater than 300 feet depth below ground surface. The data were divided into zones on the basis of open interval depths for wells as listed in the well drillers' reports. Aquifer thickness values were (1) entered in Well_Log on the basis of lithology indicated in the drillers' log or (2) assumed to be the thickness between the water level in the well and the well bottom.

A transmissivity map for the 0 to 300-foot zone (Figure 3-5) suggests that the bulk of transmissivity values calculated for shallow aquifers in the Treasure Valley are less than 200,000 ft²/day. Isolated areas with comparatively high transmissivity values

⁵ Data for this section were compiled and plotted by Rick Carlson, formerly with IWRRI.

⁶ The Well_Log data base is being developed and maintained by IDWR with data from well drillers' reports.

(> 600,000 ft²/day) were noted northeast and southeast of Lake Lowell and just north of the Boise River near Eagle. These high transmissivity values correlate with areas underlain by both gravel and basalt.

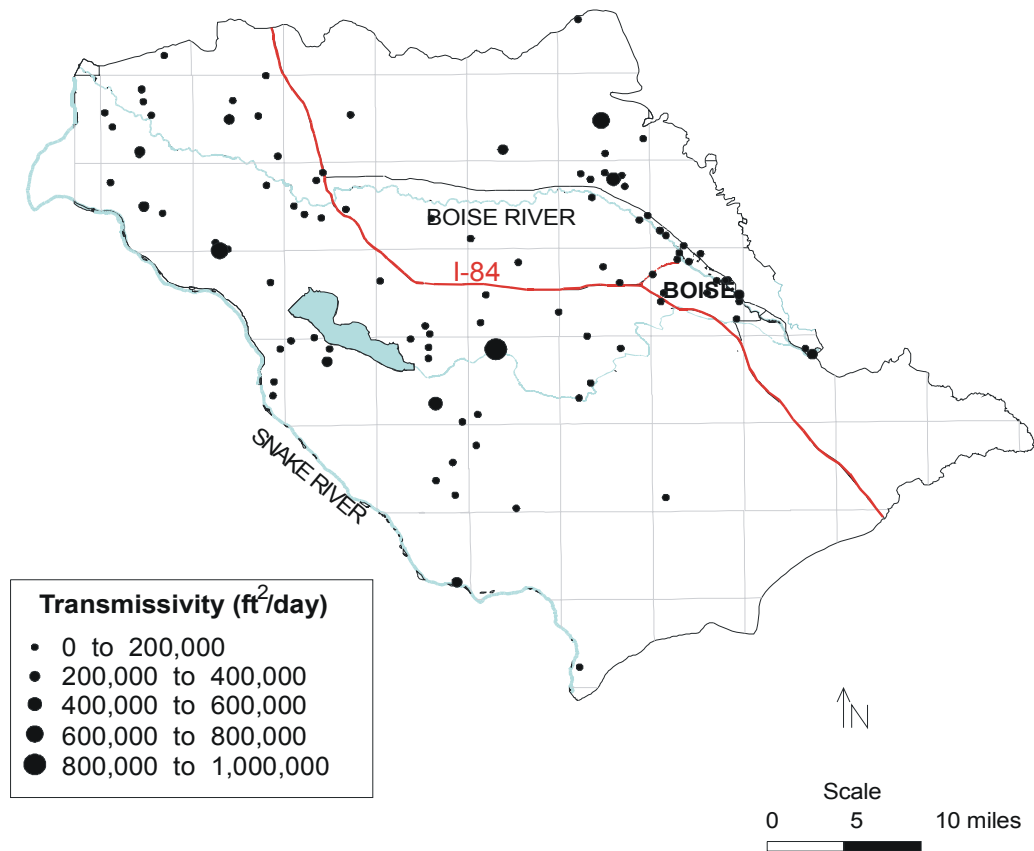

(Based on specific capacity data for wells with screened interval beginning at less than 300 feet below land surface)

Figure 3-5: Transmissivity estimates for wells completed between 0 and 300 feet below ground surface.

The map for the greater-than-300-foot zone (Figure 3-6) suggests that transmissivity values are comparatively greater at depth. The majority of calculated transmissivity values for deep aquifers across the Treasure Valley ranged between 200,000 and 400,000 ft²/day. Isolated areas of higher transmissivity (600,000 to 800,000 ft²/day) were apparent beneath west Boise, about 5 miles south of Boise, and 2 miles south of

Lake Lowell. These areas of high transmissivity are believed to correlate with deep aquifers containing zones of coarser-grained sediments⁷.

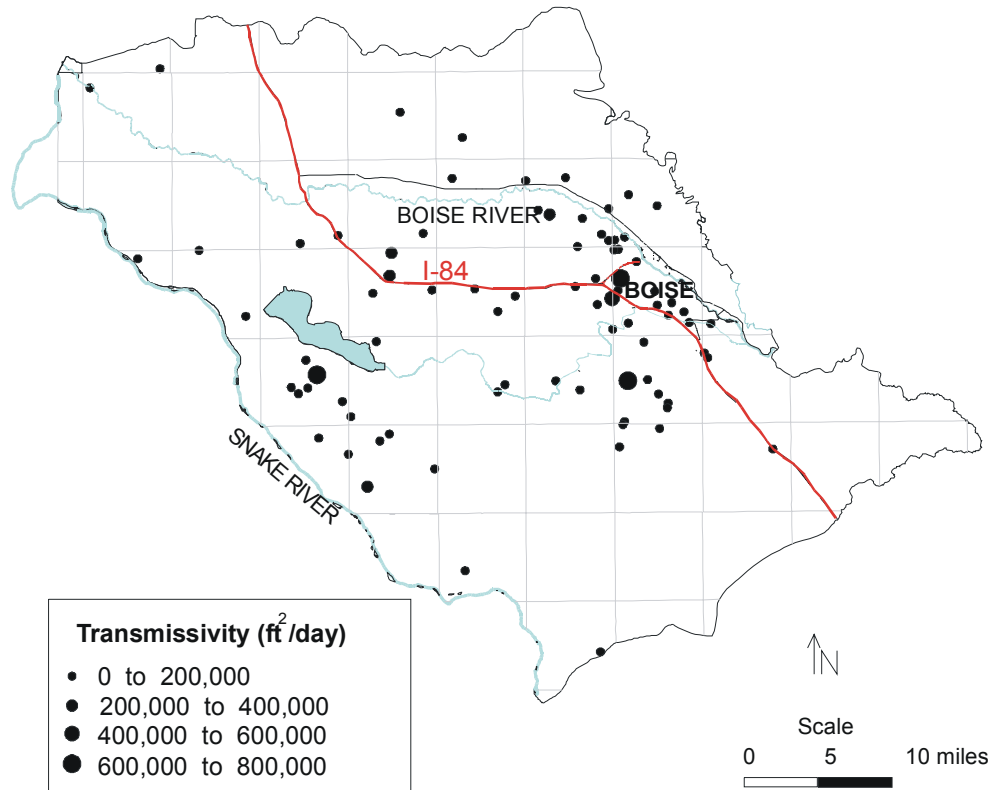

(Based on specific capacity data for wells with screened interval beginning at greater than 300 feet below land surface)

Figure 3-6: Transmissivity estimates for wells completed below 300 feet below ground surface.

In addition, aquifer parameter estimates were compiled from various single- and multi-well aquifer test results. The source of these data includes various reports prepared by public agencies and private consultants. Test locations are shown in Figure 3-7. A table of values is provided in Appendix B. Estimated hydraulic conductivity values ranged from 2.49×10^3 to 1.0×10^5 ft/day.

⁷ These conclusions may be skewed because (1) low-producing wells may not have been completed, and therefore are not included here, and (2) most of the wells used for aquifer tests are designed for production, and therefore are completed in the most productive zones.

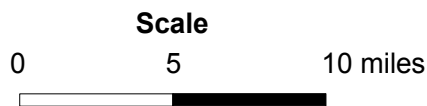
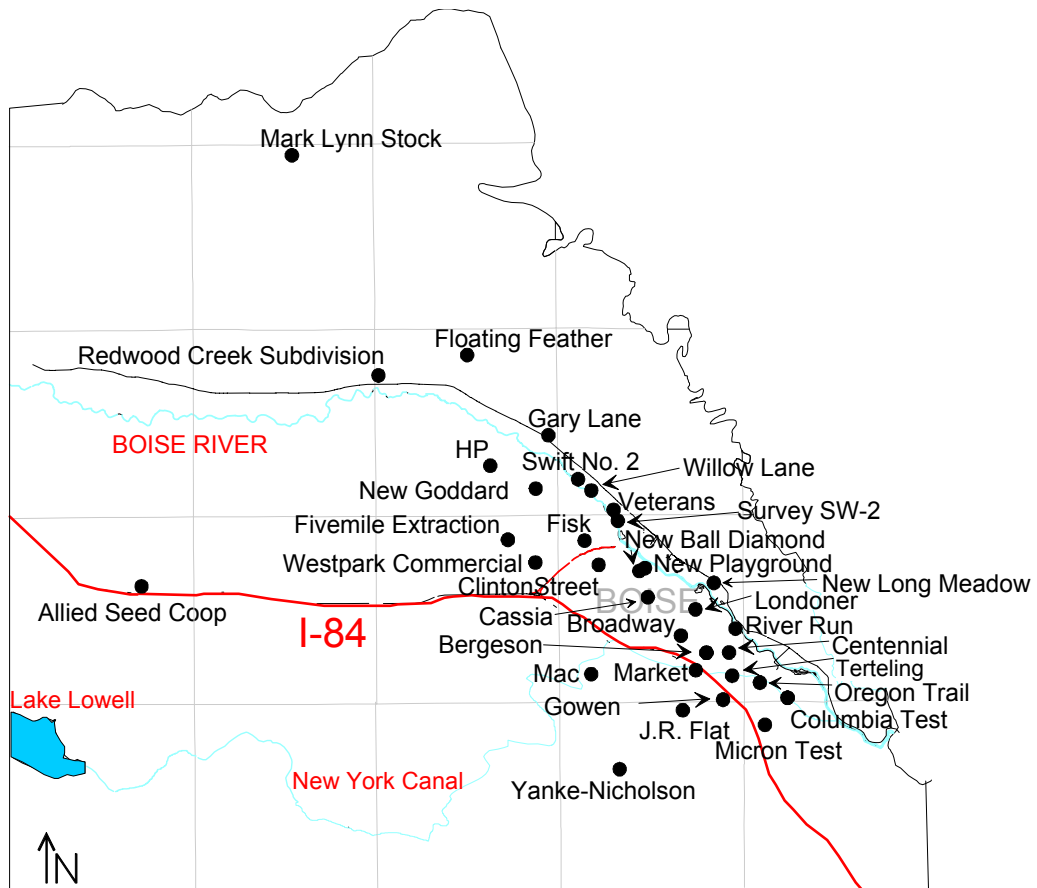

- Pumping well location

Figure 3-7: Locations of selected single and multiple well aquifer tests.

3.8. Geothermal System

The “cold water” aquifer system contained in the Snake River and Idaho Groups is underlain by a low-temperature geothermal⁸ aquifer system. Temperatures of the low-temperature geothermal water range from 85° to 175°F along the Boise Front⁹ (Petrich, 2003). The geothermal system provides heating for numerous Boise buildings and residences. In some areas, apparent upwelling from the geothermal system appears to influence potable non-geothermal ground water chemistry, evidenced by elevated concentrations of fluoride and other constituents.

The geothermal water along the Boise Front is associated with the Miocene basalts and underlying rhyolite (Wood and Burnham, 1987, p.121). Geothermal water rises from fractured rhyolite along the northwest-trending fault zone that marks the northeastern boundary of the Snake River Plain. A conceptual geothermal water circulation loop was described by Wood and Burnham (Wood and Burnham, 1987, p.121; Wood and Low, 1988, p.32-33), in which meteoric water from surrounding highlands circulates through deep fractures in the Idaho Batholith. The extent of the rhyolite aquifer into the valley is unknown. The rhyolite is present along the northern and southern margins of the WSRP, but no wells in the central part of the valley have extended into rhyolite (S. Wood, pers. comm., 1996). Potentiometric surface maps based on the 2002 mass measurements in geothermal wells suggest a westerly or southwesterly hydraulic gradient in the Boise Front area (Petrich, 2003).

It is important to differentiate between geothermal water and water that is greater than 85°F found in deeper Idaho Group sediments. Geothermal water from the rhyolite aquifers generally contains greater concentrations of sodium, bicarbonate, sulfate, chloride, fluoride, silica, arsenic, boron, and lithium than the overlying non-geothermal systems (Wood and Low, 1988, p.32). Upper aquifers, even if containing warm water, generally have higher concentrations of calcium and magnesium than the geothermal system. Squires and Wood (1989) note that ground water taken from Tenmile Ridge wells exhibits warm temperatures (70° to 88° F), but does not contain the high fluoride content associated with geothermal water on the north side of the Boise Valley. This lack of chemical similarity suggests that, with the exception of the fault zone area along the Boise Foothills, (1) the hydraulic connection between aquifers in the Idaho Group sediments and the geothermal rhyolite aquifers is limited, or (2) the volume of cold water entering the Idaho Group aquifers is much larger than the volume of geothermal water entering the Idaho Group aquifers.

⁸ “Low-temperature geothermal water” is defined by Idaho Code (I.C. § 42-233) as ground water with a temperature greater than 85°F but less than 212°F.

⁹ Boise Front describes the portion of the Idaho Batholith that forms the northeastern boundary of the lower Boise River basin.

Limited hydraulic interaction between the geothermal rhyolite aquifers and the non-geothermal aquifers in the Idaho Group is attributed to low permeabilities of the materials separating the aquifer zones. Miocene basalt and tuffaceous sediments overlying the rhyolite geothermal aquifer have low permeability because of clay alteration and minerals filling the fractures (Squires and Wood, 1989, S. Wood, pers. comm., 1997)S. Wood, pers. comm., 1997). Low permeability mudstone (which may be more than several hundred feet thick) at the base of the Idaho Group sediments further restricts the vertical permeability and hydraulic connection. However, elevated fluoride and temperature in some non-geothermal aquifers (along the Boise Front and in an area southwest of Nampa) indicates that some upwelling does occur.

4. DEDICATED TVHP MONITORING WELLS

Four multi-completion monitoring wells were constructed as a part of the TVHP (Figure 4-1). The purpose of the wells was to provide water level and chemistry data at different depths and locations within the aquifer system. A summary of screened intervals for the multiple-completion wells is provided in Table 4-1. Appendix A provides construction details and stratigraphic data for each of the wells. Geophysical data for wells TVHP #1, TVHP #2, and TVHP #4 are also provided in Appendix A.

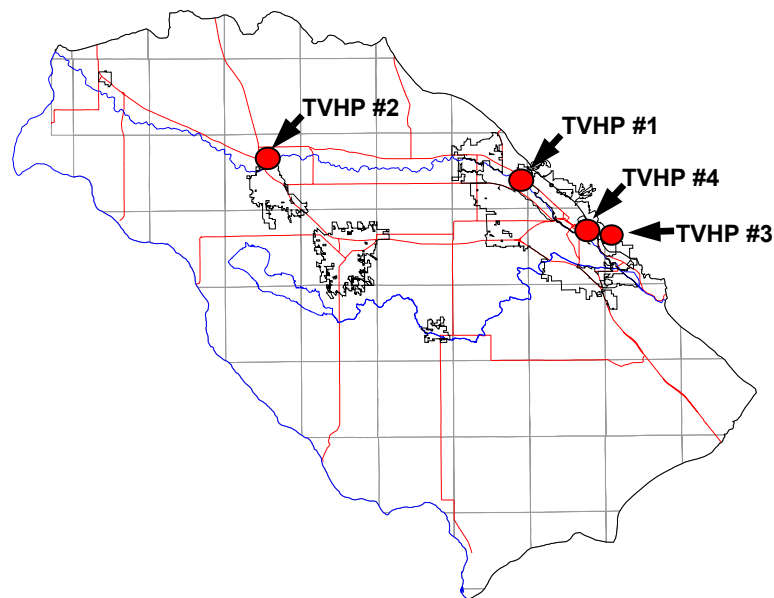

Figure 4-1: TVHP monitoring well locations.

Monitoring well TVHP #1 was drilled and constructed by United Water Idaho, Inc. (UWID) during December 1996. The well was drilled as a deep exploratory test well, and was originally drilled to evaluate potential aquifer units that might be developed for municipal water supply (Dittus and Squires, 1998). The borehole was drilled to a depth of 1,050 feet below ground surface but was subsequently backfilled to 357 feet. Four piezometers were then installed, with completion depths ranging from 170 to 340 feet. Water quality analyses from these piezometers showed the aquifers were not suitable for use as a municipal supply. UWI donated the well to the TVHP for use as a long-term monitoring well, and IDWR purchased an access easement to the well from a private landowner. Water levels (Figure 4-2) indicate an upward hydraulic gradient and apparent influences of nearby withdrawals and/or recharge.

Well Name	Piezometer	Screened Intervals – Depth below ground surface (feet)
TVHP #1 (Near Eagle)	Zone 1	300-310, 330-340
	Zone 2	270-290
	Zone 3	210-220, 240-250
	Zone 4	130-140, 150-170
TVHP #2 (Caldwell)	Zone 1	912-922, 932-942
	Zone 2	679-689, 699-709
	Zone 3	516-536
	Zone 4	376-396
	Zone 5	238-248
	Zone 6	182-192
	Zone 7	142-152
	Zone 8	110-120
TVHP #3 (Quarry View Park)	1	600-700
	2	813-848
TVHP #4 (Municipal Park)	1	35-55
	2	190-210
	3	300-320
	4	450-470
	5	710-730

Table 4-1: Construction details for TVHP monitoring wells.

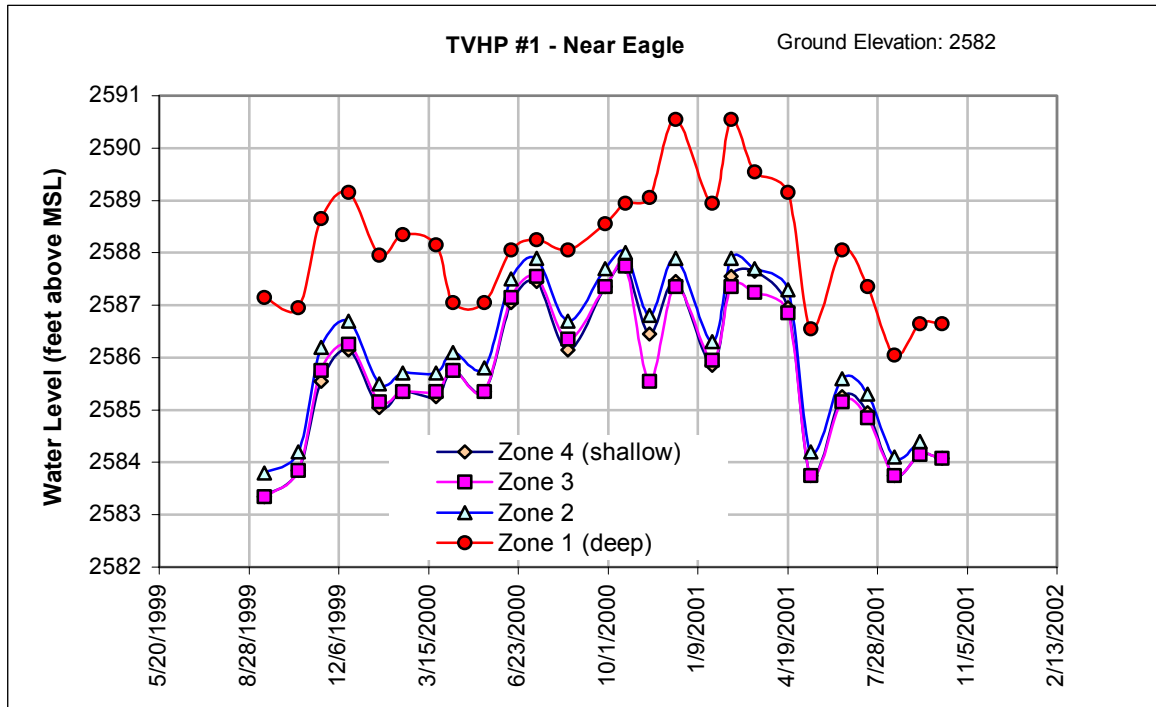

Figure 4-2: Hydrograph for TVHP #1.

Monitoring well TVHP #2 was constructed within the city of Caldwell during 1999. As with TVHP #1, this borehole was drilled for the purpose of seeking an additional source of municipal water. The city of Caldwell and IDWR agreed to share the cost of completing the borehole as a multi-level monitoring well (with in-kind technical support by UWID). Completed with eight piezometers, this well nest has completion depths ranging from 120 to 942 feet. Hydraulic head measurements (Figure 4-3) indicated a strong upward gradient between 725 feet and shallower zones and a moderate upward gradient from 550 feet to shallower zones. The vertical head differences ranged from 35 to 41 feet (upward gradient) between 11/30/99 and 6/20/01, with an average difference of 37 feet. The four uppermost completions (between 122 and 270 feet depth) are relatively consistent, indicating the possibility of a high degree of hydraulic connection between these zones. There appears to be a slight downward gradient from 725 to 1,010 feet. All completions above and including 550 feet show influences of seasonal withdrawals (i.e., summer declines).

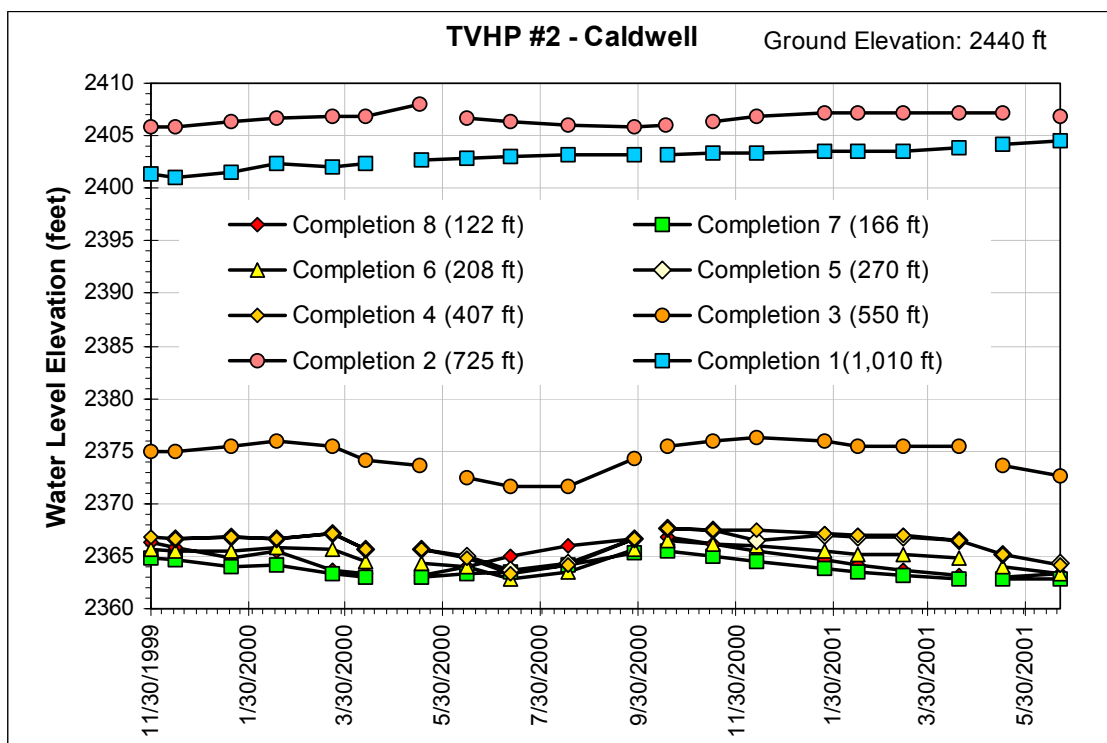

Figure 4-3: Hydrograph for TVHP #2.

Monitoring well TVHP #3 was completed in June 2001. Originally drilled in 1983, the well was used to irrigate the nearby Quarry View Park. The deepest completion produced geothermal water. Production ceased in 1988 to reduce geothermal water use (Scanlan, 2001). The well was then converted to a dual-level monitoring well by the city of Boise and IDWR as part of the TVHP. Water levels in the Quarry View well

were virtually identical between September 2001 and October 2003 (Figure 4-4), indicating close hydraulic connection between screened intervals. Decreased summer water levels indicate nearby irrigation influences.

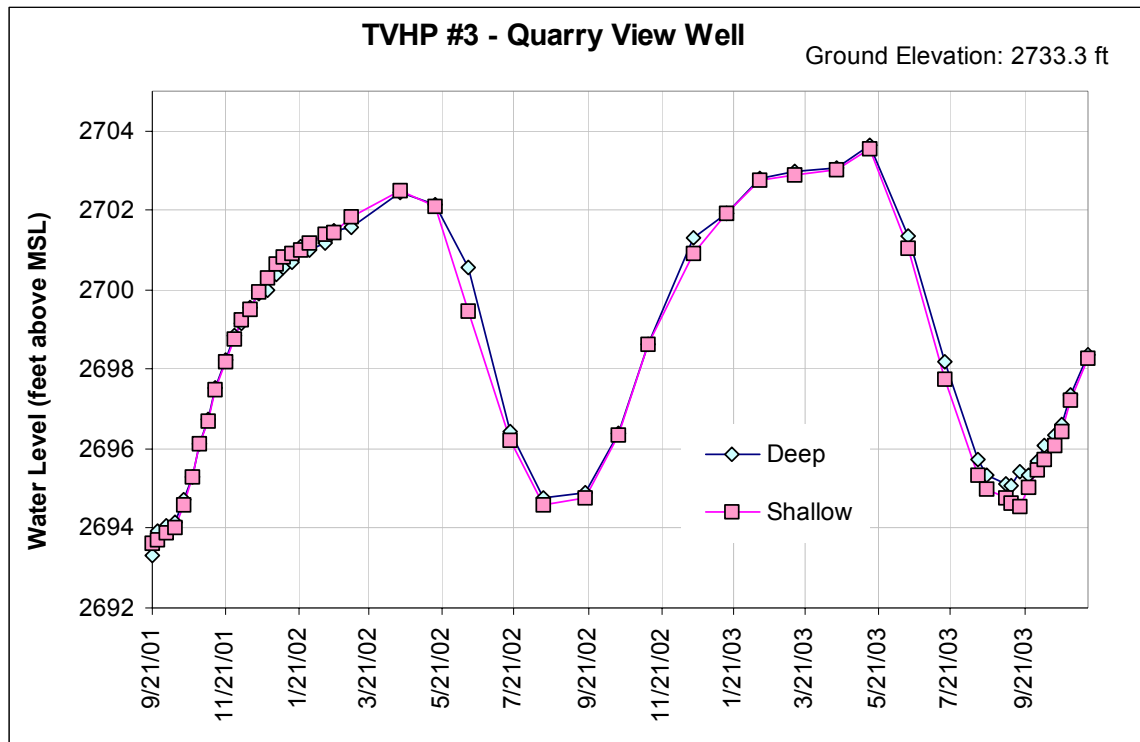
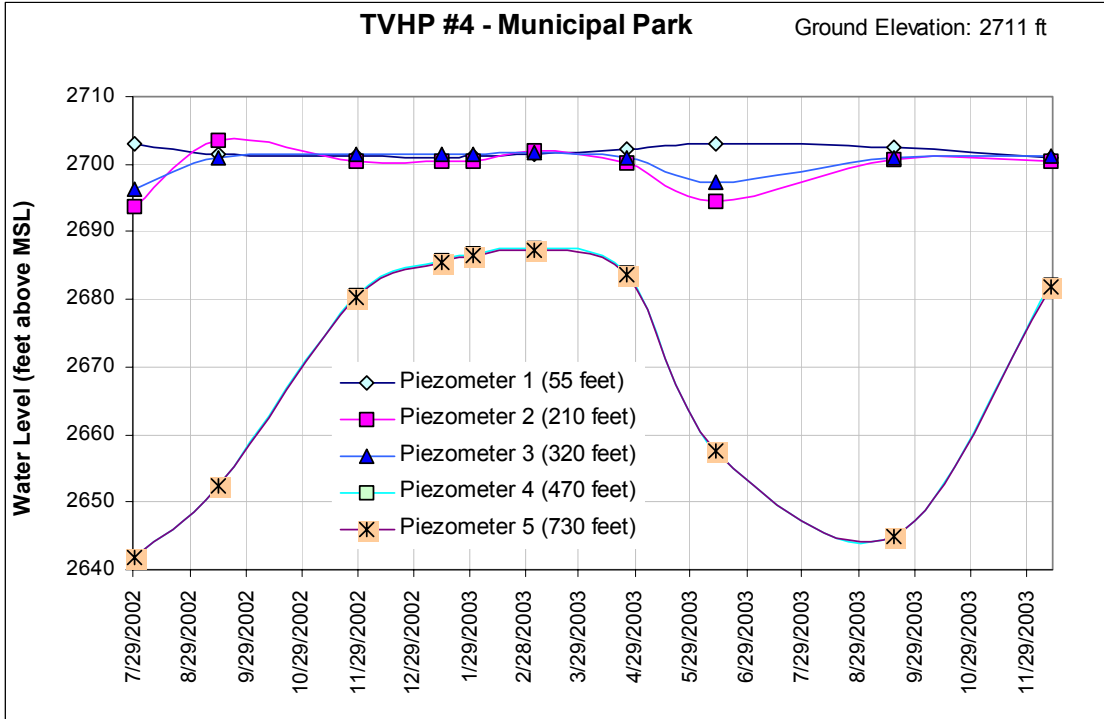

Figure 4-4: Hydrograph for TVHP #3.

Monitoring Well TVHP #4 was completed in July 2002. Located in the southeast corner of Boise’s Municipal Park, this well was constructed as a multi-completion monitoring well in an area of downward hydraulic gradients. Initially drilled to a depth of 800 feet, this well includes five piezometers ranging in depth from 55 to 730 feet. Water levels in this well (Figure 4-5) indicate similar water levels in the upper three completions and lower water levels in the lowest two completions, confirming a downward hydraulic gradient. Water level differences in the Boise Municipal Park monitoring well ranged from about 15 to 61 feet between 7/29/02 and 4/24/03 (downward gradient). Decreased water levels in the deepest completions during summer months reflect nearby municipal and irrigation withdrawals. Several municipal wells are located near monitoring well TVHP #4, with peak usage of these wells occurring during the summer months; some are not used at all during the winter and spring months (R. Dittus, pers. comm., 2003).



Piezometers 4 and 5 indicate virtually the same water level elevations.

Figure 4-5: Hydrograph for TVHP #4.

5. GROUND WATER LEVELS

5.1. Introduction

Water level measurements conducted as part of the TVHP include seven mass ground water level measurements in approximately 300 wells and monthly ground water level measurements in approximately 70 wells. This section describes and presents results from these measurements.

5.2. Mass Ground Water Level Measurements

A “mass measurement” consists of a series of ground water level measurements taken within a short period of time (in this case, one to two weeks). The purpose of a mass ground water level measurement is to define a *potentiometric surface* at a point in time. A potentiometric surface represents the levels to which water rises in wells over a given area. The water table is the potentiometric surface of an unconfined aquifer. There may be more than one potentiometric surface for a given area if the hydraulic head¹⁰ varies significantly with depth. A contour map describing a potentiometric surface is used for evaluating ground water flow directions and hydraulic gradients.

Mass ground water level measurements were conducted as part of the TVHP in the spring and fall of 1996, 1998, 2000, and fall 2001. Water levels throughout the Treasure Valley were measured within a one- to two-week time period during each mass measurement. This section describes the selection of mass measurement wells and presents potentiometric surface maps created with the mass measurement data.

The U.S. Geological Survey (USGS) selected wells for the mass measurements and performed the water level measurements. The USGS selected wells by:

1. Identifying candidate wells from the USGS Ground Water Site Inventory (GWSI) database.
2. Categorizing candidate wells on the basis of open intervals in shallow, deep, and geothermal aquifers.
3. Choosing wells that are spatially and vertically distributed throughout the Treasure Valley (where possible) in the non-geothermal aquifers. The shallow aquifer was targeted for about 60% of the measurements.

The numbers of wells included in the mass measurements are shown in Table 5-1. Additional wells were included for use in developing potentiometric surfaces if they were measured at approximately the same time as

¹⁰ Hydraulic head consists of elevation head and pressure head; the hydraulic head for a given aquifer zone is indicated by the water level in a well screened in the aquifer zone.

the mass measurement. The open interval of each well was categorized by depth on the basis of ground water flow model layers (see Petrich, 2004a, for more information)

Table 5-2). Wells with screen openings in layers 3 and 4 are grouped together in the subsequent potentiometric surface maps because of the relatively small number of wells in each zone.

Mass Measurement	Number of Wells	Measuring Entity
Spring 1996	343	USGS
Fall 1996	342	USGS
Spring 1998	383	USGS
Fall 1998	372	USGS
Spring 2000	392	USGS
Fall 2000	390	Kleinfelder, Inc.
Fall 2001	341	Kleinfelder, Inc.

Table 5-1: Numbers of wells measured during each of four mass water level measurements.

Layer	Thickness (feet)	Depth below Potentiometric Surface (feet)
Layer 1	200	0-200
Layer 2	200	200-400
Layer 3	400	400-800
Layer 4	400	800-1200

(see Petrich, 2004a, for more information)

Table 5-2: Model layer thicknesses.

Well construction details for the mass measurement wells are provided in Appendix D. The information includes:

1. Well codes indicating whether the well was used only as a mass measurement well or also for monthly well measurements
2. Well use (e.g., municipal, domestic, irrigation, industrial, etc.)
3. Upper and lower screen opening elevations (provides a basis for associating water level data with model layers)
4. Total screen length
5. Aquifer penetration depth (depth of standing water in well)

The aquifer penetration depth is provided because even deep wells may only penetrate a short distance into an aquifer. Lack of well depth data indicates that there is no drillers' log available for the well¹¹.

5.2.1. Data Collection

Water level measurements during 1996-2000 were collected by the USGS; Kleinfelder, Inc., collected water levels in fall 2000 and 2001. Pre-measurement tasks included contacting owners for permission to measure wells, preparing field maps, forms, and other necessary equipment, and assembling a field crew. Measurement tasks included visiting well sites, measuring and recording water levels, and updating well inventory information. Post-measurement tasks included entering measurement and inventory data into USGS GWSI database and publishing measurements in USGS annual water data reports.

5.2.2. Potentiometric Surface Maps

Potentiometric surface contour maps based on kriged interpolations for the mass measurements conducted in spring and fall of 1996, 1998, and 2000, and fall 2001 (for shallow, intermediate, and deep zones) are provided in Appendix E. Monitoring wells with open intervals in the layer of interest are shown with gray dots. Three examples of potentiometric surface plots are shown in Figure 5-1 through Figure 5-3. The following sections describe some of these figures.

There are several observations that can be made from the potentiometric surface maps presented in the previous sections and in Appendix E. In general, contour maps drawn from mass measurement data indicate ground water flow from the eastern part of the valley toward the west, except for the area south of Boise, where ground water flow is to the south or southwest. Potentiometric surface contours in the southeastern portion and parts of the northern part of the study area are uncertain because of the paucity of data in these areas.

¹¹ A few wells were used for water level measurements despite the lack of well construction or lithologic information because they were located in areas of few or no other observation alternatives.

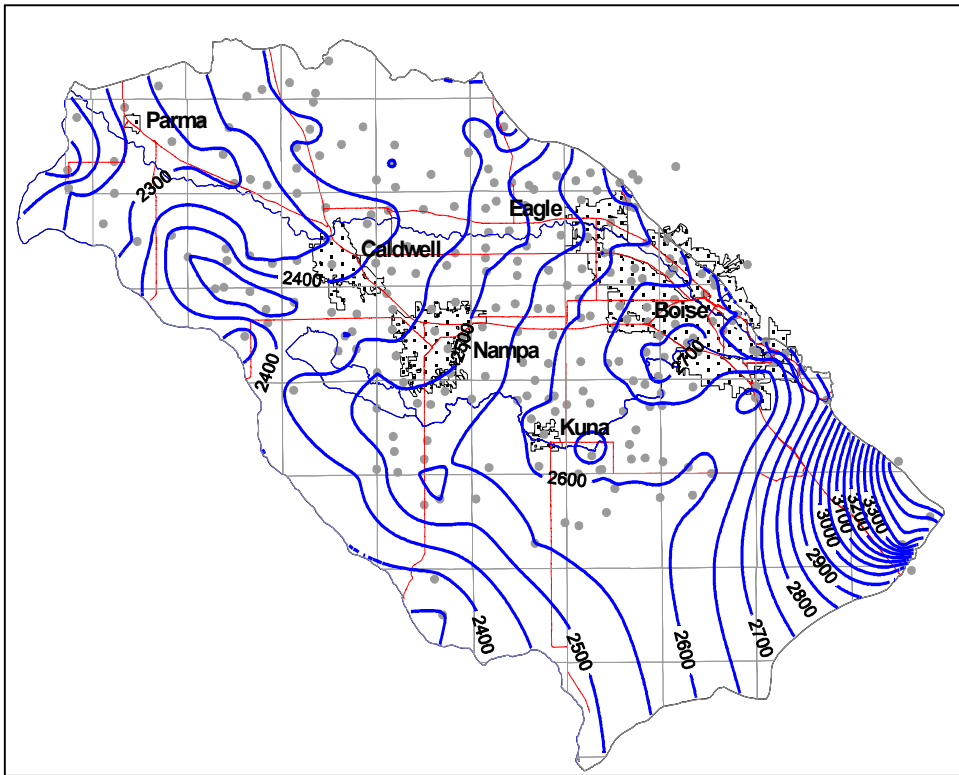

Figure 5-1: Potentiometric surface, spring 1996, shallow zone (240 wells).

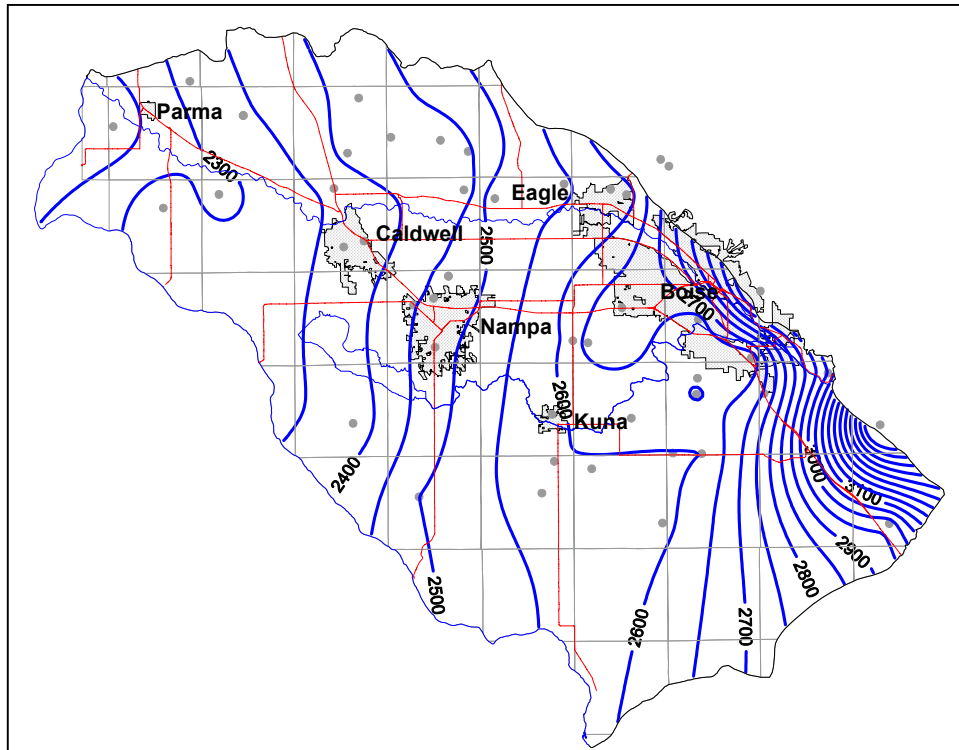

Figure 5-2: Potentiometric surface, spring 1996, intermediate zone (49 wells).

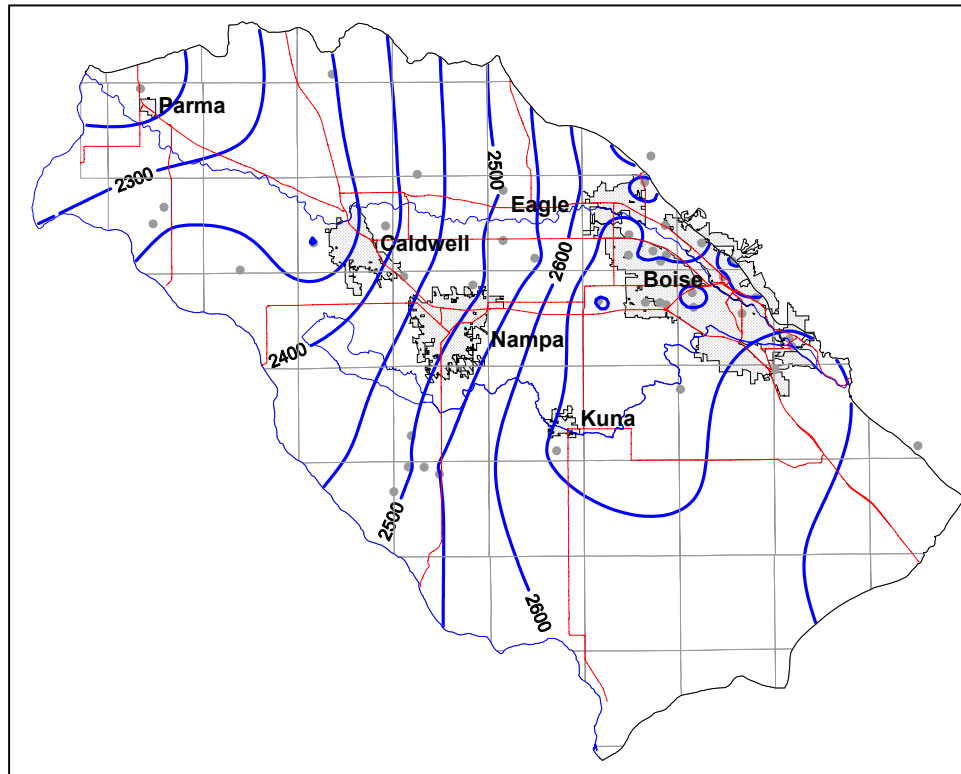

Figure 5-3: Potentiometric surface, spring 1996, deep zone (45 wells).

Additional specific observations include the following:

1. Potentiometric contours from deeper aquifer zones indicate ground water movement in a westerly direction.
2. Potentiometric surface contours in maps indicate ground water mounding in the vicinity of the New York and Mora Canals, presumably from canal leakage (Berenbrock, 1999; Carlson and Petrich, 1998) and infiltration from irrigated fields.
3. Ground water mounding appears in the area northwest of Lake Lowell.
4. Ground water mounding appears to form a ground water divide between the Boise and Snake Rivers along the New York and Mora Canals, and extending northwest from Lake Lowell. North of these canals ground water flows toward the Boise River, south of these canals hydraulic gradients indicate ground water flow toward the Snake River. The effects of ground water mounding underneath the New York Canal are evident in both the potentiometric surfaces based on shallow and deeper wells, although water from the New York Canal is not reaching these lower zones (Hutchings and Petrich, 2002b).
5. The potentiometric surface maps indicate ground water movement from the Boise Foothills in a west-southwest direction toward the Boise River.

5.2.3. Seasonal Water Level Changes

Seasonal water level changes occur in the Treasure Valley in response to ground water withdrawals, surface irrigation, and canal leakage. Figure 5-4 illustrates seasonal water level changes between spring and fall 1996. The map was prepared by subtracting fall potentiometric surface in the shallow zone from that of the spring potentiometric surface in the shallow zone. The map indicates general ground water level increases (in the uppermost aquifer zone) in the central portion of the valley south of the Boise River. These rises were attributed to infiltration associated with summer irrigation. Ground water declines are indicated in the southwestern portion of the valley, though these declines appear to be associated with select wells and may not necessarily reflect regional trends.

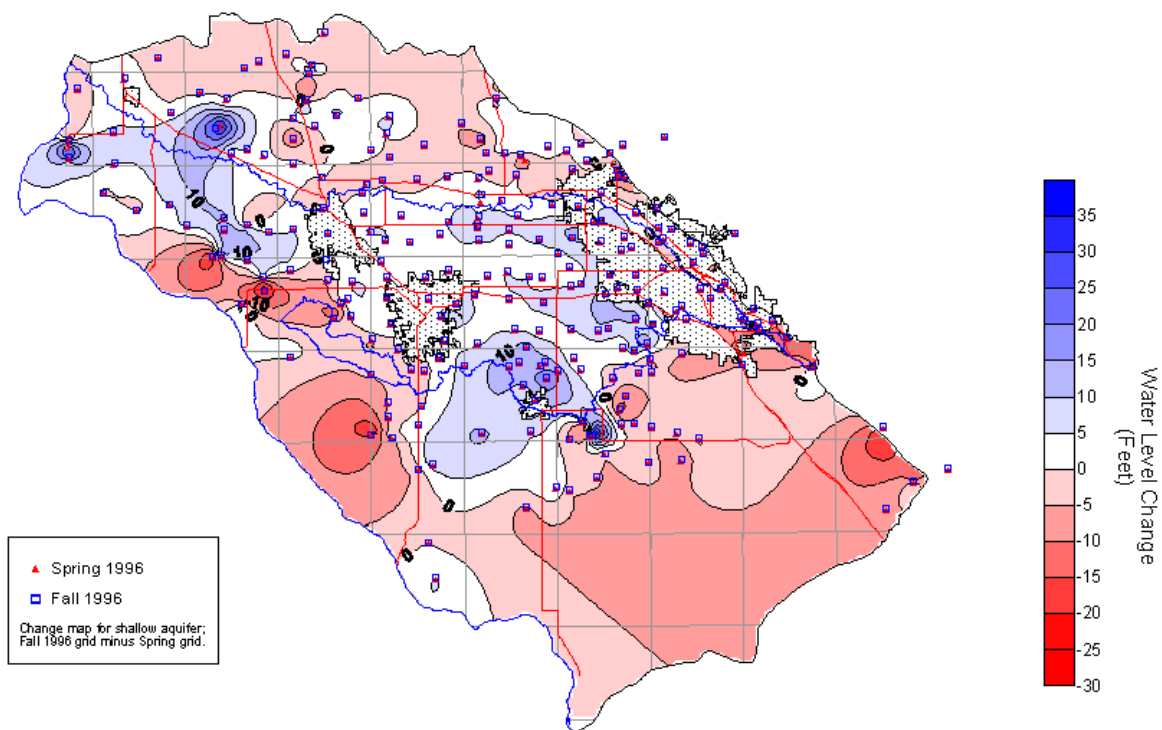

Figure 5-4: Spring and fall 1996 change map.

The reliability of the water level change map is limited by the reliability of the spring and fall water level interpolations. The interpolations, and comparisons based on interpolations, may contain substantial error, especially in areas containing few data points (such as areas along the periphery of the project area).

5.3. Periodic Ground Water Level Monitoring

Monthly, quarterly, or semi-annual ground water level measurements were made in a variety of Treasure Valley wells. The monitoring network and monitoring results are described in the following sections.

5.3.1. Well Network Description

The TVHP monitoring well network consisted of approximately 72 wells¹². The purpose of the periodic measurements was to provide a basis for (1) evaluating seasonal fluctuations in water levels and (2) establishing long-term water level trends. The wells were measured on a monthly basis from 1996 through 2001, and measured on a quarterly basis thereafter. The locations of the monthly monitoring wells are shown in Figure 5-5. Well construction details for these wells are provided in Appendix D.

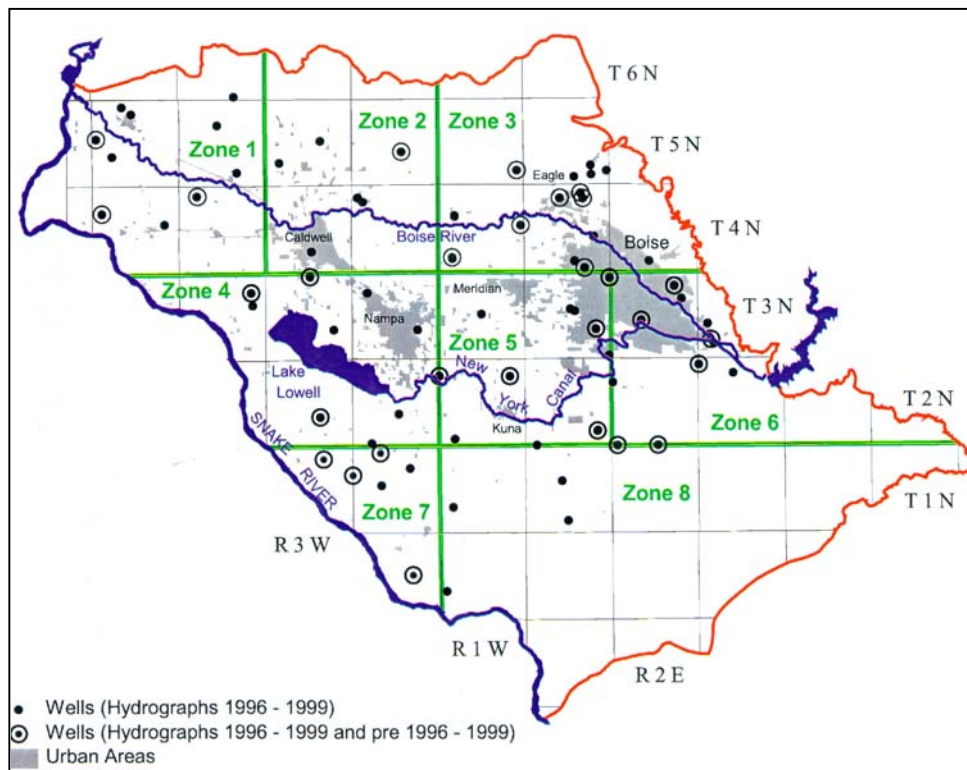

Figure 5-5: Locations of hydrograph wells

¹² These wells were also included in the mass measurements described in Section 5.2.

Thirty of the TVHP monitoring wells have been monitored cooperatively by the IDWR and the USGS since the 1950s. Water levels in these wells (referred to as “co-op wells”) were measured primarily on a semi-annual basis, although a few of the wells were measured more frequently. The measurement frequency in these wells was increased to a monthly basis in 1996 as part of the TVHP.

Forty-two wells were added to the monthly measurement program in 1996. The 42 monitoring wells were selected from 305 wells measured in the spring 1996 mass water-level measurement. Criteria for selecting the additional monitoring wells included

1. Spatial distribution throughout project area
2. Available drillers’ report
3. Reasonably detailed lithologic log
4. Discrete open interval, preferably corresponding with specific aquifer depths
5. Access to well by USGS, IDWR, or other personnel for conducting measurements

5.3.2. Hydrographs

Water level measurements from these wells were used to construct well hydrographs. Hydrographs from the TVHP monthly monitoring wells for April 1996 through December 2002 are presented in Appendix F. These hydrographs are organized by area for convenience (Figure 5-5). Hydrographs from wells with a longer sampling record (long-term “co-op” wells) are also presented in Appendix F.

Hydrograph data indicate that (1) water levels in many parts of the valley appear to be relatively stable, but water level declines have occurred in some areas; (2) long term water level increases have occurred in some areas; and (3) most wells fluctuate on a seasonal basis. The seasonal variations can be caused by pumping, recharge, or both.

In general, water levels in many parts of the valley appear to be relatively stable from year to year. Some of the stability reflects shallow water levels in the central and western parts of the valley that are being controlled by topography (e.g., the elevations of canals and drains). There are, however, a number of wells that have experienced increasing or decreasing water levels (Table 5-3). Of the 32 wells with long-term data records, approximately 13 showed water level decreases and 5 showed increases (the rest were relatively stable)¹³. Of the 71 wells with short-term records (which includes all of the wells with long-term records), approximately 24 showed some amount of

¹³ The number of wells showing water level increases or decreases is somewhat subjective.

water level decrease and 8 showed increases. The greatest declines have occurred in the area south of Lake Lowell (declines of about 65 feet) and southeast Boise (declines of 30 feet). Water levels in several intermediate and deep wells have declined in areas 3 and 5 (Figure 5-5 and Appendix F), which represent the central portion of the basin (west Boise, Eagle, Meridian, and Kuna).

The wells showing water level increases or decreases (Table 5-3) may or may not reflect regional conditions. For example, increased withdrawals from an extraction well used for monitoring (or a nearby pumping well) may cause an apparent local decline that does not reflect regional water levels. A field survey of select wells (Figure 5-6) was conducted during August 1999 to determine the possible cause of the water level changes. Each well was visited and any obvious changes in land use that may have contributed to the observed water level changes were noted. Appendix G contains hydrographs for these wells, including a brief description of what may have contributed to the observed water level changes. In most cases, wells displaying decreasing trends are located in areas that appeared to be undergoing transitions from flood irrigated farmland to residential development. It is unclear whether observed drawdowns in these areas reflect local equilibria required for increased withdrawals or regional ground water level declines. Additional monitoring is recommended in these areas using non-pumping wells.

	Area (see Figure 3-7)	Total Number of Wells in Area	Number of Wells with Increasing Water Level (categorized by total well depth below ground surface)			Number of Wells with Decreasing Water Level (categorized by total well depth below ground surface)		
			0-200'	200- 400'	>400'	0-200'	200- 400'	>400'
Long-Term Data Record (> 7 years)	1&2	4		1		1		
	3	9				3	3	1
	4	3				1		
	5	5				1	1	2
	6	6			2	1		
	7 & 8	5			2			
Total number of wells		32		1	4	6	4	3
Short-Term Data Record (~7 years)	1	10				1		
	2	6			1	2		
	3	15				5	1	3
	4	9		1	1	3		
	5	11				3	4	
	6	10		2	2		1	
	7	5			1			1
	8	5						
Total number of wells		71		3	5	14	6	4

Table 5-3: Approximate number of monitoring wells with increasing or decreasing water levels.

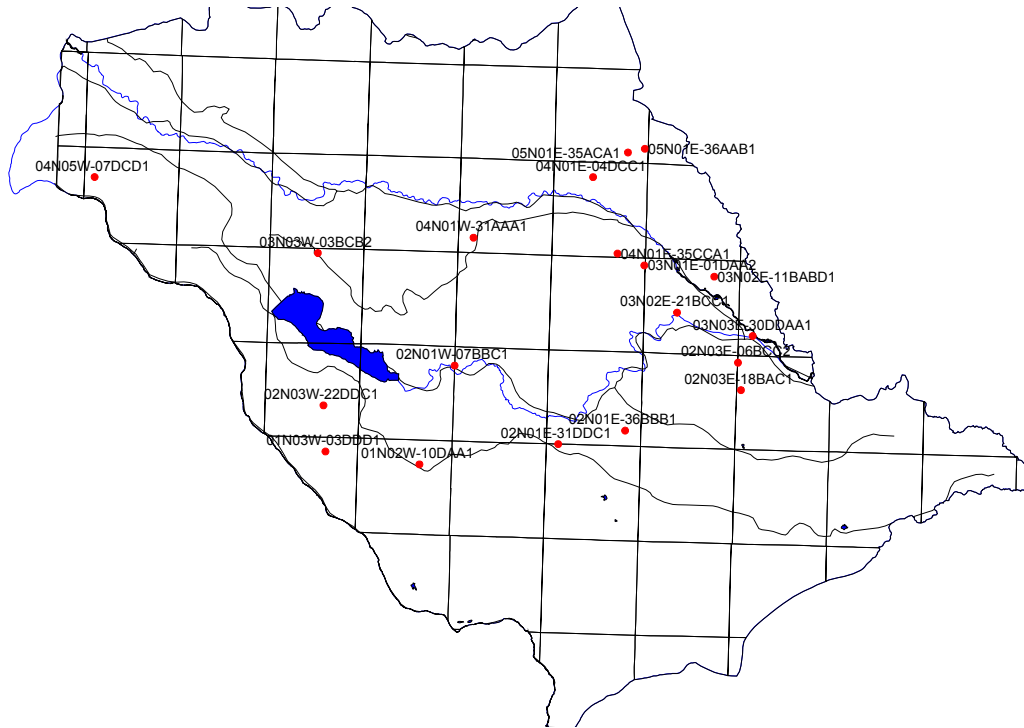

Figure 5-6: Locations of wells showing substantial water level changes.

6. AQUIFER INFLOWS AND OUTFLOWS

6.1. Introduction

An annual water budget was prepared for the Treasure Valley aquifer system for the calendar year 1996 (Urban and Petrich, 1998). The water budget provides an estimate of the current balance between total aquifer withdrawals and discharge, aquifer recharge, and changes in aquifer storage. Specific objectives for this water budget were to (1) define major water budget components, (2) estimate inflows and outflows for the Treasure Valley aquifer systems, (3) describe, where possible, the spatial characteristics of inflows and outflows, (4) create GIS coverages of the water budget data, and (5) create input files (e.g., recharge, withdrawals and ET) for the Treasure Valley ground water flow model. A revised 1996 water budget was completed more recently (Urban, 2004) and also includes a water budget for the year 2000.

6.2. 1996 Water Budget

Inflows to the Treasure Valley aquifer system include (1) seepage from canals and irrigated fields, (2) seepage from rivers and streams, (3) seepage from Lake Lowell, (4) underflow, (5) infiltration of precipitation and surface water, and (6) seepage from rural domestic septic systems. Outflows include (1) municipal withdrawals, (2) industrial withdrawals, (3) irrigation withdrawals, (4) rural domestic withdrawals, (5) stock withdrawals, (6) discharge to canals, drains, and rivers, and (7) evapotranspiration.

Total inflow (Table 6-1) into the Treasure Valley aquifer system was estimated to be 1,035,000 acre-feet (af) in 1996, while total outflow was estimated to be 999,000 af. The net difference shows an apparent increase in aquifer storage of 36,000 af. This difference is less than 4% of the total recharge or discharge and is well within the estimated margin of error of individual component estimates.

The largest source of estimated ground water recharge was seepage from the canal system, followed by seepage from flood irrigation and precipitation. The aggregate discharge to the Boise and Snake Rivers (through canals, drains, or direct discharge) is far greater than all withdrawals combined. On a valley-wide basis, the volume of annual ground water withdrawals represents approximately 20% of the total 1996 ground water recharge (Table 6-1).

Sources of Recharge and Discharge	Estimated Recharge/Discharge for 1996	
	acre-feet	Percent of Total
Recharge¹		
Canal Seepage	637,000	61
Seepage from Rivers and Streams	16,000	1
Seepage from Lake Lowell	19,000	2
Underflow	8,000	1
Flood Irrigation and Precipitation ²	302,000	30
Recharge by Other Land Uses ³	48,000	4
Rural Domestic Septic Systems	5,000	<1
Total Recharge¹	1,035,000	
Discharge		
Domestic and Industrial Withdrawals	66,000	6
Municipal Irrigation	10,000	1
Self-Supplied Industrial	21,000	2
Agricultural Irrigation	72,000	7
Rural Domestic Withdrawals	27,000	2
Stock Watering	3,000	<1
Discharge to Rivers and Drains	800,000	81
Total Discharge	999,000	
Net Difference⁴	+36,000	

1. See text for explanations; values shown in this table are rounded to the nearest 1,000 acre-feet.
2. Includes recharge from precipitation and irrigation on flood-irrigated lands only.
3. Includes recharge from precipitation by land use; does not include flood-irrigated land.
4. Because of the error associated with the individual water budget components, a positive net difference does not necessarily indicate a positive change in aquifer storage.

Table 6-1: Summary of recharge and discharge estimates contained in the 1996 water budget.

Primary ground water withdrawal and recharge areas do not necessarily coincide throughout the valley. The primary recharge areas are those with extensive canals and/or flood irrigation, while the greatest withdrawals occur in areas that are not flood irrigated. For example, agricultural irrigation withdrawals (non-supplemental) are concentrated in areas where surface water irrigation is unavailable, and municipal withdrawals are concentrated near the urban areas of Boise, Nampa, Caldwell, and Meridian. As a result, withdrawals may exceed recharge in local areas within the Treasure Valley, resulting in local water level declines. Water level increases were noted in areas where recharge appears greater than local withdrawals.

The aggregate nature of the water budget masks the differences between inflows to and outflows from individual aquifer zones. Much of the inflow may only recharge shallow aquifers; recharge to deeper zones depends on local vertical hydraulic gradients and aquifer material properties. Recharge to deeper zones is estimated to be a small portion of the total aquifer inflows (Petrich, 2004a).

The aggregate nature of the water budget also masks the temporal characteristics of ground water recharge, withdrawals, and natural discharge. Infiltration from the

surface water distribution system and irrigation occurs primarily in the summer. The actual aquifer recharge from irrigation activities lags the initial infiltration, thus water levels may be rising months after irrigation has ceased. Municipal withdrawals also vary throughout the year but are generally greatest during the summer irrigation season.

Several general conclusions were drawn from this 1996 water budget:

1. The largest components of aquifer recharge in the Treasure Valley are seepage from the canal system and infiltration associated with irrigated agriculture.
2. Discharge to rivers, drains, and canals is the largest source of discharge from the Treasure Valley aquifer system.
3. Overall, aggregate aquifer recharge to the Treasure Valley aquifer system appears to be in dynamic equilibrium with the aggregate aquifer discharge. The net difference between estimated recharge and discharge is well within the error range of the large water budget components and is therefore negligible.
4. Recharge to shallow Treasure Valley aquifers is influenced significantly by land use (by the location of irrigation activities).

7. TREASURE VALLEY GROUND WATER FLOW CHARACTERISTICS

This section presents a summary of ground water flow in the Treasure Valley based on the descriptions of aquifer characteristics (Section 3, page 13), water level measurements (Section 5, page 36), and inflows and outflows (Section 6, page 46). This summary represents a “conceptual model” of ground water flow in the basin that was the basis for a series of aquifer simulations (Petrich, 2004a; 2004b).

The Treasure Valley aquifer system is comprised of a complex series of interbedded, tilted, faulted, and eroded sediments extending to depths of over 6,000 feet in the deepest parts of the basin (Wood and Clemens, in press). The valley contains shallow, local flow systems (with ground water residence times ranging from years to hundreds of years) and a deep, regional flow system (with residence times ranging from hundreds to tens of thousands of years). Few water wells extend beyond a depth of about 1,200 feet.

The Treasure Valley sedimentary section reflects a history of lacustrine, deltaic, fluvial, and alluvial deposition (see Section 3.3). In general, basin sedimentary deposits grade from coarser, more permeable sediments near the Boise Front to finer, less permeable sediments at the distal end of the basin. At the basin scale, sediments also grade finer with depth. Highly permeable deposits associated with deltaic and/or fluvial deposition are often sandwiched between lacustrine deposits of lower permeability.

Ground water flow in the Treasure Valley is controlled by aquifer characteristics and hydraulic gradient. Aquifer characteristics influencing ground water flow include grain size, sorting, stratigraphic layering, sedimentary layer dip, sediment grain cementation, and the degree of fracturing (in basalt aquifers). Additional controls on the movement of ground water are attributed to structural processes, including faulting throughout the basin and along the basin margin. A series of southeast-northwest trending faults dissect the valley, with stratigraphic offsets of several hundred feet or more. Analyses of aquifer test data from southeast Boise (West and Osiensky, 1999) indicate negative boundary conditions associated with faults in the southeast Boise area. Artesian conditions just north of the Boise River in the vicinity of monitoring well TVHP #1 may be created in part by restricted flow across the Eagle–West Boise Fault Zone (Figure 3-2). Ground water chemistry data (Hutchings and Petrich, 2002a) indicate different ground water chemistry north of the fault zone compared to the area south of the fault zone, suggesting restricted flow across the fault zone. Basin downwarping and an associated downslope trend in sediment deposition contribute to steeply dipping sedimentary deposits that may cause deeper aquifer units to pinch out at depth (Wood, 1997a). Based on seismic imaging and outcrop mapping, aquifer sediments of various fault blocks are dipping at angles ranging from zero to approximately 12 degrees (Wood, 1997a).

Fractures within shallow Pleistocene basalts or along upper and lower surfaces of individual basalt flows can contribute to ground water movement. For instance, basalt fractures and coarse-grained sediments underlying the basalt may greatly contribute to transmitting leakage from the New York Canal (and other surface water channels) into shallow aquifers.

An erosional unconformity associated with changing lake levels in Pliocene Lake Idaho truncates down-dipping units near the basin margin near Boise (Squires and Wood, 2001; Squires et al., 1992; Wood, 1997a). The unconformity separates lacustrine and deltaic sediments (tilted in the Boise area) from overlying lacustrine/deltaic sediments. Coarse-grained sediments associated with the erosional unconformity (Squires et al., 1992; Wood, 1997a) appear to serve as a manifold for deeper, regional ground water migrating horizontally into the basin from alluvial fan sediments in the eastern portion of the basin (corroborated by E. Squires, pers. comm., 2002).

Potentiometric surface contours indicate ground water movement in a westerly to southwesterly direction, depending on depth and location (Section 5.2.2, page 38). Potentiometric surface contours in shallow aquifer zones reflect surface hydrologic conditions, such as mounding under the New York and Mora Canals (e.g., Figure 5-1) or discharge to the Boise River. The mounding in the vicinity of the New York Canal represents a local ground water divide, with shallow ground water north of the canal flowing toward the Boise River and shallow ground water south of the canal flowing toward the Snake River. Potentiometric surface contours from shallow aquifers show ground water flow toward and discharge to the Boise River in mid- to lower reaches. Potentiometric surface contours in deeper zones indicate a more uniform westerly flow direction (Section 5.2.2, page 38). Downward hydraulic gradients are indicated along the Boise Foothills, the eastern part of the study area (see TVHP #4 well in Figure 4-5), and in the vicinity of the New York and Mora Canals. Upward gradients are evident in the central and western portions of the valley (see TVHP #2 hydrographs in Figure 4-3) and in the vicinity of the Boise River.

Individual hydrographs (Section 5.3 and Appendix F) indicate relatively stable water levels in many areas, although water level declines have occurred in a number of wells. Wells in two areas, southeast Boise (e.g., well 03N03E-30DDAA1) and south of Lake Lowell (e.g., well 03N04W-11ADA1), have experienced declines of approximately 30 feet and 65 feet, respectively. Water levels in these areas appear to have stabilized in recent years.

Additional ground water level declines were observed (Appendix F and Table 5-3) in areas 3 (northwest Boise and Eagle, Figure 5-5) and 5 (southwest Boise, Meridian, and Kuna). Most of the long-term declines in these wells have been less than 10 feet. Reasons for the declines may include increased withdrawals from the measured wells

(very few of the monitoring wells are dedicated to monitoring alone), increased nearby withdrawals, and/or changes in local infiltration rates (Appendix G). Further investigation of these apparent declines is warranted to determine if they reflect regional or local conditions. Additional monitoring wells would also be warranted in these areas of apparent declines.

A number of shallow monitoring wells indicated water level decreases (Table 5-3). Shallow wells may be especially sensitive to changes in local surface water irrigation patterns in areas where the water table is not in direct hydraulic connection with surface channels. Ground water level changes are less likely in shallow wells in areas where the water table is controlled by topography (by virtue of drains and canals).

Seasonal water level fluctuations are evident in many Treasure Valley wells. The fluctuations generally are a response to seasonal increases in withdrawals (e.g., summer irrigation withdrawals) or increases in recharge associated with surface water irrigation.

The largest component of recharge to shallow aquifers is seepage from the canal system and infiltration associated with irrigated agriculture (Urban, 2004; Urban and Petrich, 1998). Water enters shallow aquifers as infiltration from canals, irrigated areas, and other water bodies (e.g., Lake Lowell), and possibly from upper reaches of the Boise River (e.g., Barber Dam to Capitol Street Bridge) during high flows. Infiltration from surface channels occurs if and when (1) water is available and (2) hydraulic heads in the channel (or lake) are higher than the surrounding aquifer heads. Additional recharge sources include mountain front recharge, underflow from the granitic Idaho Batholith and tributary sedimentary aquifers, and direct precipitation.

Shallow aquifer levels increased by as much as 100 feet in some areas in response to the initiation of large-scale flood irrigation in the late 1800s and early 1900s. Shallow ground water levels rose to and remained at (or near) ground surface in many areas (at least seasonally), discharging to drains and other surface channels.

Shallow and intermediate aquifers are separated from deeper zones by interbedded silt and clay layers in many parts of the valley. While individual clay layers are not necessarily areally extensive, multiple clay layers in aggregate form effective barriers to vertical ground water movement.

Recharge to the deeper aquifers begins as downward flow through coarse-grained alluvial fan sediments in the eastern portion of the basin and as underflow at basin margins. Ground water is then thought to flow horizontally into the basin via more permeable sediments (e.g., coarse-grained sediments of the geological unconformity overlying Chalk Hills sediments), intersecting the alluvial fan sediments.

This is illustrated in water chemistry data collected from shallow aquifers near the New York Canal. Water in the canal, as in upper portions of the Boise River, has relatively low specific conductance (and by inference, total dissolved solids). In shallow aquifers underlying the canal, specific conductance was found to increase with depth, corresponding with canal water that has infiltrated through soil horizons. In contrast, water in deeper sand units separated from upper zones by multiple clay layers has lower specific conductance than water in overlying horizons (Hutchings and Petrich, 2002a; Hutchings and Petrich, 2002b). This finding indicates that water in at least some deeper aquifers originates at the basin margins and does not enter the ground water regime through the carbon-rich sediments found in Treasure Valley soils.

Residence times of Treasure Valley ground water were generally found to increase with depth and distance along a regional east-to-west-trending flow path (Hutchings and Petrich, 2002a). Residence time estimates ranged from thousands to tens of thousands of years. The youngest waters entered the subsurface a few thousand years ago and were found along the northeastern boundary of the basin, adjacent to the Boise Foothills. The oldest waters entered the subsurface between 20,000 and 40,000 years ago and were found in the western reaches of the basin near the Snake River. Ground water in the deep deltaic aquifers beneath Boise entered the subsurface between 10,000 and 20,000 years ago.

Comparisons between measured water chemistry constituents and established models of geochemical processes (Hutchings and Petrich, 2002a) show that (1) ground water near the northeastern basin margin has experienced little interaction with aquifer minerals, and (2) ground water beyond the northeastern basin margin has experienced substantial interaction with aquifer minerals. Geochemical evolution of Treasure Valley ground water appears to be influenced by solution of both carbonate and silicate minerals.

Ground water discharge to rivers, drains, and canals represents the dominant form of discharge from the Treasure Valley aquifer system (Urban and Petrich, 1998). The primary form of natural discharge from the deeper aquifers is thought to be regional upwelling in the southern and western portions of the basin, with ultimate discharge to the Boise River and/or Snake River. Rates of discharge from the deeper aquifers in the western portions of the valley are unknown but are probably low because of the thick accumulation of lacustrine clays separating these aquifers from ground surface.

Relatively long residence times in the regional flow system (over 20,000 years) implies that (1) regional aquifers are not very transmissive, (2) recharge rates to the deeper regional aquifers are very limited, and/or (3) regional aquifers are discharge-limited. Although there are abundant silt and clay layers with low hydraulic conductivity, productive sand layers are present throughout central portions of the valley; these sand zones are tapped by many irrigation and municipal wells. Recharge to the deeper,

regional system is limited but has generally been sufficient for current rates of withdrawal. Thick lacustrine clays at the distal end of the valley likely inhibit upward (discharge) flow, limiting the amount of water that can flow through the system.

In summary, the Treasure Valley aquifer system consists of shallow aquifers containing local ground water flow systems and a deeper, regional ground water flow system. Recharge to the shallow system consists largely of infiltration from irrigated fields and canals. Primary discharge is to the Boise and Snake Rivers and other streams and to drains discharging into these channels. The deeper, regional flow system consists of (1) recharge in alluvial sediments in southeast Boise and at the base of the mountain front north of Boise, (2) movement of ground water from the recharge areas into the deeper Boise area fluvio-lacustrine aquifers, and (3) movement of ground water from the Boise area aquifers into regional lacustrine/deltaic aquifers in the central and western portions of the valley.

8. REFERENCES

- Anderson, J.E. and Wood, S.H., 1981. Geological, Hydrological Geochemical and Geophysical Investigations of the Nampa-Caldwell and Adjacent Areas, Southwestern Idaho. Chapter 3, Geohydrology, In: Mitchell, J. C., ed., Geothermal Investigations in Idaho, Part 11: Idaho Department of Water Resources, Water Information Bulletin 30: p. 33-42.
- Barrash, W. and Dougherty, M.E., 1995. High-Resolution Seismic Reflection Profiling and Modeling of the Hydrogeologic System, Goddard 2 Well, Northwest Boise, Idaho. Center for Geophysical Investigation of the Shallow Subsurface, Boise State University.
- Berenbrock, C., 1999. Streamflow Gains and Losses in the Lower Boise River Basin, Idaho, 1996-97. U.S. Geologic Survey, Water-Resources Investigations Report 99-4105.
- Beukelman, G., 1997a. Cross Section of the Treasure Valley in the Boise Area: Notes on the Geology of the Boise Area. Department of Geosciences, Boise State University, prepared for the Treasure Valley Hydrologic Project.
- Beukelman, G., 1997b. Cross Section of the Treasure Valley in the Notus Area: Notes on the Geology of the Notus area, Gem, Payette, Canyon, and Owyhee Counties, Idaho. Department of Geosciences, Boise State University, prepared for the Treasure Valley Hydrologic Project.
- Beukelman, G., 1997c. Cross Section of the Treasure Valley in the Ontario Area: Notes on the Geology of the Ontario area, Payette and Canyon Counties, Idaho, and Malheur County, Oregon. Department of Geosciences, Boise State University, prepared for the Treasure Valley Hydrologic Project.
- Beukelman, G., 1997d. Cross Section of the Treasure Valley in the Parma Area: Notes on the Geology of the Ontario area, Payette, Canyon, and Owyhee Counties, Idaho. Department of Geosciences, Boise State University, prepared for the Treasure Valley Hydrologic Project.
- Brockway, C.E. and Brockway, C.G., 1999. Southeast Boise Aquifer Simulation and Aquifer Recharge and Recovery Evaluation. Brockway Engineering, prepared for Micron Technology, Inc.
- Burnham, W.L. and Wood, S.H., 1992. Geologic Map of the Boise South Quadrangle, Ada County, Idaho. Preprint in review for the Idaho Geological Survey Technical Report Series, April 22, 1992.
- Carlson, R.A. and Petrich, C.R., 1998. New York Canal Geologic Cross Section, Seepage Gain/Loss Data, and Ground Water Hydrographs: Compilation and Findings. Idaho Water Resources Research Institute and Idaho Department of Water Resources.
- Clemens, D.M., 1993. Volcanic stratigraphy and tectonic development, Western Snake River Plain, Idaho. M.S. Thesis, Arizona State University.

- Cook, Z., Urban, S., Maupin, M., Pratt, R. and Church, J., 2001. Domestic, Commercial, Municipal, and Industrial Water Demand Assessment and Forecast in Ada and Canyon Counties, Idaho. Idaho Department of Water Resources.
- Dion, N.P., 1972. Some effects of land-use changes on the shallow ground-water system in the Boise-Nampa Area, Idaho. Idaho Department of Water Administration, Water Information Bulletin No. 26.
- Dittus, R., Allred, J. and Squires, E., 1998. Supporting Data for Groundwater Conditions and Aquifer Testing of the Tenmile Ridge Area of South Boise, Ada County, Idaho. United Water Idaho Groundwater Report Series Data Release No. 98-D1.
- Dittus, R., Allred, J. and Squires, E., 1999. Hydrogeology, Geochemistry, and Well Construction of the Treasure Valley Hydrologic Project Monitoring Well #1, Ada County, Idaho. United Water Idaho, Prepared for the Treasure Valley Hydrologic Project.
- Driscoll, F.G., 1986. Groundwater and Wells. Johnson Division, St. Paul, MN.
- Hutchings, J. and Petrich, C., 2002a. Ground water recharge and flow in the regional Treasure Valley aquifer system - geochemistry and isotope study. Idaho Water Resources Research Institute, Research Report IWRRI-2002-08.
- Hutchings, J. and Petrich, C., 2002b. Influence of canal seepage on aquifer recharge near the New York Canal. Idaho Water Resources Research Institute, Research Report IWRRI-2002-09.
- Kimmel, P.G., 1982. Stratigraphy, Age, and Tectonic Setting of the Miocene-Pliocene Lacustrine Sediments of the Western Snake River Plain, Oregon and Idaho. Cenozoic Geology of Idaho. Idaho Bureau of Mines and Geology Bulletin 26, pp. 559-578 pp.
- Liberty, L.M., 1996a. Seismic Reflection Imaging of the Boise Geothermal Aquifer. Center for the Geophysical Investigation of the Shallow Subsurface, Boise State University, BSU CGISS 96-05, Boise, ID.
- Liberty, L.M., 1996b. Seismic Reflection Results: Stewart Gulch Region, Boise, Idaho. Center for Geophysical Investigation of the Shallow Subsurface, Boise State University, BSU CGISS 96-04.
- Liberty, L.M., 1998. Seismic reflection imaging of a geothermal aquifer in an urban setting. *Geophysics*, 63(4): 1285-1294.
- Liberty, L.M. and Wood, S.H., 2001. Treasure Valley Seismic Reflection Project - UPRR 2000 Profile. Center for Geophysical Investigation of the Shallow Subsurface, Department of Geosciences, Boise State University, CGISS 01-01.
- Lindgren, J.E., 1982. Application of a ground water model to the Boise Valley Aquifer in Idaho. M.S. Thesis, University of Idaho.
- Lindgren, W., 1898. Description of the Boise Quadrangle, Idaho. U.S. Geological Survey.
- Mabey, D.R., 1982. Geophysics and tectonics of the Snake River Plain, Idaho. In: Bill Bonnicksen and R. M. Breckenridge, editors, *Cenozoic Geology of Idaho*. Idaho Bureau of Mines and Geology Bulletin 26: 193-153.

- Malde, H.E., 1991. Quaternary geology and structural history of the Snake River Plain, Idaho and Oregon. In: *The Geology of North America, Quaternary Nonglacial Geology: Conterminous U.S.*, Vol. K-2, 252-281 pp.
- Malde, H.E. and Powers, H.A., 1962. Upper Cenozoic stratigraphy of Western Snake River Plain. *Geological Society of America Bulletin*, 73: 1197-1220.
- Neely, K.W. and Crockett, J.K., 1998. Ground water quality characterization and initial trend analysis for the Treasure Valley shallow and deep hydrologic subareas. Idaho Department of Water Resources, No. 50 Part 3.
- Newton, G.D., 1991. Geohydrology of the regional aquifer system, Western Snake River Plain, Southwestern Idaho. U.S. Geological Survey Professional Paper 1408-G.
- Othberg, K.L., 1994. Geology and geomorphology of the Boise Valley and adjoining areas, western Snake River Plain, Idaho. *Idaho Geological Survey Bulletin* 29: 54 pp.
- Othberg, K.L. and Stanford, L., 1992. Geologic map of the Boise Valley and adjoining area, Western Snake River Plain, Idaho. Idaho Geological Survey.
- Petrich, C., 2003. Investigation of Hydrogeologic Conditions and Ground Water Flow in the Boise Front Geothermal Aquifer (Executive Summary). Idaho Water Resources Research Institute, Research Report IWRRI-2003-07.
- Petrich, C.R., 2004a. Simulation of Ground Water Flow in the Lower Boise River Basin. Idaho Water Resources Research Institute, Research Report IWRRI-2004-02.
- Petrich, C.R., 2004b. Simulation of Increased Ground Water Withdrawals in the Treasure Valley Associated with Unprocessed Well Applications. Idaho Water Resources Research Institute, Research Report IWRRI-2004-03.
- Petrich, C.R., 2004c. Treasure Valley Hydrologic Project - Executive Summary. Idaho Water Resources Research Institute, Research Report IWRRI-2004-04.
- Ralston, D.R. and Chapman, S.L., 1970. Ground-water resource of southern Ada and western Elmore Counties, Idaho. Idaho Department of Reclamation, Water Information Bulletin No. 15.
- Scanlan, T.M., 2001. Final Report on the Quarry View Park Well Project. Scanlan Engineering, prepared for the City of Boise.
- Squires, E. and Derricott, S.L., 1992. Hydrogeologic investigation for the proposed State of Idaho, Department of Transportation Blacks Creek rest area, Ada County Idaho. A report to the Idaho State Department of Transportation.
- Squires, E. and Wood, S., 1989. Investigation of groundwater in the Tenmile Ridge area of South Boise, Idaho. Department of Geology and Geophysics, Boise State University, Boise, Idaho.
- Squires, E., Wood, S., Osiensky, J. and Dittus, R., 1993. Groundwater conditions and hydraulic testing of the Boise-Fan Aquifer of Southeast Boise River Valley, Ada County, Idaho. prepared for the Boise Water Corporation.
- Squires, E. and Wood, S.H., 2001. Stratigraphic Studies of the Boise (Idaho) Aquifer System using Borehole Geophysical logs with Emphasis on Facies Identification of Sand

- Aquifers, prepared for the Treasure Valley Hydrologic Study, Idaho Department of Water Resources.
- Squires, E., Wood, S.H. and Osiensky, J.L., 1992. Hydrogeologic Framework of the Boise Aquifer System, Ada County, Idaho. Research Technical Completion Report, Idaho Water Resources Research Institute, University of Idaho. 114 pp.
- Urban, S.M., 2004. Water Budget for the Treasure Valley Aquifer System for the Years 1996 and 2000. Idaho Department of Water Resources.
- Urban, S.M. and Petrich, C.R., 1998. 1996 Water Budget for the Treasure Valley Aquifer System. Idaho Department of Water Resources Research Report.
- West, S. and Osiensky, J., 1999. Analysis of aquifer test data from selected southeast Boise wells, Idaho.
- Wood, S.H., 1994. Seismic expression and geological significance of a lacustrine delta in Neogene deposits of the Western Snake River Plain, Idaho. AAPG Bulletin, 1(January): p. 102-121.
- Wood, S.H., 1996a. Cross Sections of the Southeast Boundary of the Treasure Valley Groundwater Study Area: Notes on the Geology of the Mayfield-Orchard Area, Ada and Elmore County, Idaho. Boise State University Geosciences, prepared for the Treasure Valley Hydrologic Project.
- Wood, S.H., 1996b. Preliminary Map of the Base of the Sedimentary Section of the Western Snake River Plain. Department of Geosciences, Boise State University, Geological interpretation for the Treasure Valley Hydrologic Project.
- Wood, S.H., 1997a. Hydrogeologic Framework of the Boise Valley of Southwest Idaho. Dept. of Geosciences, Boise State University.
- Wood, S.H., 1997b. Structural contour map of the top of Miocene basalt basement rocks, Western Snake River Plain, Idaho.
- Wood, S.H., 1997c. Structure Contour map of the Top of the Mudstone Facies, Western Snake River Plain, Idaho. Geosciences Department, Boise State University.
- Wood, S.H. and Anderson, J.E., 1981. Part 11: Geological, hydrological, and geochemical and geophysical investigations of the Nampa-Caldwell and adjacent areas, southwestern Idaho. In: J.C. Mitchell (Editor), Geothermal investigations in Idaho. Idaho Department of Water Resources.
- Wood, S.H. and Burnham, W.L., 1987. Geologic Framework of the Boise Warm Springs Geothermal Area, Idaho. Geological Society of America Centennial Field Guide-Rocky Mountain Section: pp. 117-122.
- Wood, S.H. and Clemens, D.M., *in press*. Geologic and tectonic history of the western Snake River Plain, Idaho and Oregon. In: B. Bonnicksen, C.M. White and M. McCurry (Editors), Tectonic and Magmatic Evolution of the Snake River Plain Volcanic Province. Idaho Geologic Survey.

Wood, W.W. and Low, W.H., 1988. Solute Geochemistry of the Snake River Plain Regional Aquifer System, Idaho and Eastern Oregon. Regional Aquifer System Analysis, U. S. Geological Survey Professional Paper 1408-D: 79 pp.

Appendix A. CONVERSION FACTORS

Volume

- 1 cubic foot of water = 7.4805 gallons = 62.37 pounds of water
- 1 acre-foot (af) = enough water to cover 1 acre of land 1 foot deep
- 1 acre-foot (af) = 43,560 cubic feet
- 1 acre-foot (af) = 325,850 gallons
- 1 million gallons = 3.0689 acre-feet

Flow Rates

- 1 cubic foot per second (cfs) = 448.83 gallons per minute (gpm) = 26,930 gallons per hour
- 1 cubic foot per second (cfs) = 646,635 gallons per day = 1.935 acre-feet per day
- 1 cubic foot per second (cfs) for 30 days = 59.502 acre-feet
- 1 cubic foot per second (cfs) for 1 year = 723.94 acre-feet
- 1 cubic meter per second (cms) = 25.31 cubic feet per second
- 1 cubic meter per second (cms) = 15,850 gallons per minute
- 1 million gallons per day (mgd) = 1,120.147 acre-feet per year
- 1 miner's inch = 9 gallons per minute
- 1 miner's inch = 0.02 cubic feet per second

Hydraulic Conductivity

- 1 gallon per day per foot² (gal/day/ft²) = 0.134 foot/day = 0.0408 meters/day

Economic

- \$0.10 per 1,000 gallons = \$32.59 per acre-foot

Appendix B. AQUIFER TEST DATA

This appendix contains selected aquifer test data (compiled by Rick Carlson, formerly with the Idaho Water Resources Research Institute). References for the aquifer test data are listed beginning on page 81.

PUMPING WELL NAME	LOCATION	DEPTH OF PUMPING WELL (FT)	COMPLETION INTERVAL(FT)	Multiple or Single Well?	PUMPING RATE (gpm)	MULTIPLE WELLS	MULTIPLE TIMES	TRANSMISSIVITY (gpd/ft)	Assumed Aquifer Thickness (ft)	HYDRAULIC CONDUCTIVITY (gpd/ft ²)	STORATIVITY	SPECIFIC CAPACITY(gpm/ft)	METHOD	DURATION (hours)	LITHOLOGY	START DATE	REFERENCE	COMMENTS
New Playground Well	3N2E9DC	260	111 - 260	m	1145	pumping well	early	13,200	150	88	***	24.0	constant rate pump test, Jacobs Semi-log Drawdown Method	8	med. Sand	2/13/92	1	A step test was completed
New Playground Well	3N2E8DC	260	111 - 260	m	1145	pumping well	late	16,000	150	107	***	24.0	constant rate pump test, Jacobs Semi-log Drawdown Method	8	med. Sand	2/13/92	1	
New Playground Well	3N2E9DC	260	111 - 260	m	1145	obs. well 1 (80ft)	early	12,300	150	82	***	24.0	constant rate pump test, Jacobs Semi-log Drawdown Method	8	med. Sand	2/13/92	1	
New Playground Well	3N2E9DC	260	111 - 260	m	1145	obs. well 1 (80ft)	late	18,300	150	122	8E-04	24.0	constant rate pump test, Jacobs Semi-log Drawdown Method	8	med. Sand	2/13/92	1	
New Playground Well	3N2E9DC	260	111 - 260	m	1145	obs. well 2 (1700ft)	early	***	150	***	***	24.0	constant rate pump test, Jacobs Semi-log Drawdown Method	8	med. Sand	2/13/92	1	
New Playground Well	3N2E9DC	260	111 - 260	m	1145	obs. well 2 (1700ft)	late	23,000	150	153	***	24.0	constant rate pump test, Jacobs Semi-log Drawdown Method	8	med. Sand	2/13/92	1	T for this well is suspect.

PUMPING WELL NAME	LOCATION	DEPTH OF PUMPING WELL (FT)	COMPLETION INTERVAL(FT)	Multiple or Single Well?	PUMPING RATE (gpm)	MULTIPLE WELLS	MULTIPLE TIMES	TRANS-MISSIVITY (gpd/ft)	Assumed Aquifer Thickness (ft)	HYDRAULIC COND-UCTIVITY (gpd/ft ²)	STORATIVITY	SPECIFIC CAPACITY(gpm/ft)	METHOD	DURATION (hours)	LITHOLOGY	START DATE	REFERENCE	COMMENTS
New Playground Well	3N2E9DC	260	111 - 260	m	1145	obs. well 3 (2000ft)	early	***	150	***	***	24.0	constant rate pump test, Jacobs Semi-log Drawdown Method	8	med. Sand	2/13/92	1	
New Playground Well	3N2E8DC	260	111 - 260	m	1145	obs. well 3 (2000ft)	late	***	150	***	***	24.0	constant rate pump test, Jacobs Semi-log Drawdown Method	8	med. Sand	2/13/92	1	
New Ball Diamond Well	3N2E9DD	435	186-396	m	1200	obs. well 1	early	58,000	150	387	***	31.0	constant rate pump test, Jacobs Semi-log Drawdown Method	24	med. Sand	3/2/92	2	
New Ball Diamond Well	3N2E9DD	435	186-396	m	1200	obs. well 1	late	13,000	150	87	7E-04	31.0	constant rate pump test, Jacobs Semi-log Drawdown Method	24	med. Sand	3/2/92	2	
New Ball Diamond Well	3N2E9DD	435	186-396	m	1200	obs. well 2	early	***	150	***	8E-04	31.0	constant rate pump test, Jacobs Semi-log Drawdown Method	24	med. Sand	3/2/92	2	High, late, T values suggest hydraulic boundaries
New Ball Diamond Well	3N2E9DD	435	186-396	m	1200	obs. well 2	late	13,000	150	87	***	31.0	constant rate pump test, Jacobs Semi-log Drawdown Method	24	med. Sand	3/2/92	2	

PUMPING WELL NAME	LOCATION	DEPTH OF PUMPING WELL (FT)	COMPLETION INTERVAL(FT)	Multiple or Single Well?	PUMPING RATE (gpm)	MULTIPLE WELLS	MULTIPLE TIMES	TRANS-MISSIVITY (gpd/ft)	Assumed Aquifer Thickness (ft)	HYDRAULIC CONDUCTIVITY (gpd/ft ²)	STORATIVITY	SPECIFIC CAPACITY(gpm/ft)	METHOD	DURATION (hours)	LITHOLOGY	START DATE	REFERENCE	COMMENTS
New Ball Diamond Well	3N2E9DD	435	186-396	m	1200	obs. well 3	early	***	150	***	3E-04	31.0	constant rate pump test, Jacobs Semi-log Drawdown Method	24	med. Sand	3/2/92	2	
Floating Feather Hills Well	4N1E3CCC	415	215-265, 375-385	m	743	pumping well	early	11,986	160	***	***	10.3	constant rate pump test, Jacobs Semi-log Drawdown Method	720	fine sand to course sand	3/26/91	3	Early T believed to be affected by casing storage.
Floating Feather Hills Well	4N1E3CCC	415	215-265, 375-385	m	743	pumping well	late	143,749	160	898	***	10.3	constant rate pump test, Jacobs Semi-log Drawdown Method	720	fine sand to course sand	3/26/91	3	
Floating Feather Hills Well	4N1E3CCC	415	215-265, 375-385	m	743	obs. well 1 (900ft)	late	83,350	160	521	0.019	10.3	constant rate pump test, Chow Semi-log Time Drawdown Method	720	fine sand to course sand	3/26/91	3	
Floating Feather Hills Well	4N1E3CCC	415	215-265, 375-385	m	743	obs. well 2 (1300ft)	early	553,418	160	3459	0.02	10.3	constant rate pump test, Chow Semi-log Time Drawdown Method	720	fine sand to course sand	3/26/91	3	High T from gravity drainage effects
Floating Feather Hills Well	4N1E3CCC	415	215-265, 375-385	m	743	obs. well 4 (2500ft)	early	681,132	160	4257	0.005	10.3	constant rate pump test, Chow Semi-log Time Drawdown Method	720	fine sand to course sand	3/26/91	3	High T from gravity drainage effects

PUMPING WELL NAME	LOCATION	DEPTH OF PUMPING WELL (FT)	COMPLETION INTERVAL(FT)	Multiple or Single Well?	PUMPING RATE (gpm)	MULTIPLE WELLS	MULTIPLE TIMES	TRANS-MISSIVITY (gpd/ft)	Assumed Aquifer Thickness (ft)	HYDRAULIC COND-UCTIVITY (gpd/ft ²)	STORATIVITY	SPECIFIC CAPACITY(gpm/ft)	METHOD	DURATION (hours)	LITHOLOGY	START DATE	REFERENCE	COMMENTS
Floating Feather Hills Well	4N1E3CCC	415	215-265, 375-385	m	743	obs. well 4 (2500ft)	late	219,720	160	1373	0.017	10.3	constant rate pump test, Chow Semi-log Time Drawdown Method	720	fine sand to course sand	3/26/91	3	
Floating Feather Hills Well	4N1E3CCC	415	215-265, 375-385	m	743	obs. well 5 (3700ft)	early	315,339	160	1971	0.017	10.3	constant rate pump test, Chow Semi-log Time Drawdown Method	720	fine sand to course sand	3/26/91	3	
Floating Feather Hills Well	4N1E3CCC	415	215-265, 375-385	m	743	obs. well 5 (3700ft)	late	287,490	160	1797	0.006	10.3	constant rate pump test, Chow Semi-log Time Drawdown Method	720	fine sand to course sand	3/26/91	3	
Broadway Well	3N2E22DD	532	250-524	m	2975	pumping well	no		225	***	***	66.0	constant rate pump test, Jacobs Semi-log Drawdown Method	6	sand	7/20/72	4	
Redwood Creek Subdivision Well No. 1	4N1E7BD	415	298-313, 361 - 401	m	2100	pumping well	no	55,000	200	275	***	24.0	constant rate pump test, Jacobs Semi-log Drawdown Method	8.5	course sand to gravel	4/7/94	5	Artesian - static water level is 5 feet above ground surface.
Redwood Creek Subdivision Well No. 1	4N1E7BD	415	298-313, 361 - 401	m	2100	obs. well 1 (2600ft)	no	154,000	200	770	2E-04	24.0	constant rate pump test, Jacobs Semi-log Drawdown Method	8.5	course sand to gravel	4/7/94	5	

PUMPING WELL NAME	LOCATION	DEPTH OF PUMPING WELL (FT)	COMPLETION INTERVAL(FT)	Multiple or Single Well?	PUMPING RATE (gpm)	MULTIPLE WELLS	MULTIPLE TIMES	TRANS-MISSIVITY (gpd/ft)	Assumed Aquifer Thickness (ft)	HYDRAULIC CONDUCTIVITY (gpd/ft ²)	STORATIVITY	SPECIFIC CAPACITY(gpm/ft)	METHOD	DURATION (hours)	LITHOLOGY	START DATE	REFERENCE	COMMENTS
Willow Lane Well Field	4N2E32BCB	90	unknown	m	1400	yes	no	274,000	90	3044	0.02	23.0	constant rate pump test, Jacobs Semi-log Drawdown Method	72	course sand to gravel	9/14/62	6	9 observation wells were monitored.
Veterans Well	4N2E32DDC	275	150-275	m	800	pumping well	yes	***	125	***	***	12.3	constant rate pump test, Jacobs Semi-log Drawdown Method	94	course sand to gravel	5/10/96	7	Unclear if time drawdown measurements were recorded from observation wells.
Veterans Well	4N2E32DDC	275	150-277	m	800	obs. well	late	10,036	125	80	***	12.3	constant rate pump test, Jacobs Semi-log Drawdown Method	94	course sand to gravel	5/10/96	7	Unclear if time drawdown measurements were recorded from observation wells.
Gary Lane Well	4N2E24DBA	837	742-837	m	600	pumping well	yes	***	100	***	***	7.8	constant rate pump test, Jacobs Semi-log Drawdown Method	34	course sand to gravel	3/23/96	8	Unclear if time drawdown measurements were recorded from observation wells.
Gary Lane Well	4N2E24DBA	837	742-837	m	600	obs. well	late	3,955	100	40	***	7.8	constant rate pump test, Jacobs Semi-log Drawdown Method	34	course sand to gravel	3/23/96	8	Unclear if time drawdown measurements were recorded from observation wells.

PUMPING WELL NAME	LOCATION	DEPTH OF PUMPING WELL (FT)	COMPLETION INTERVAL(FT)	Multiple or Single Well?	PUMPING RATE (gpm)	MULTIPLE WELLS	MULTIPLE TIMES	TRANS-MISSIVITY (gpd/ft)	Assumed Aquifer Thickness (ft)	HYDRAULIC CONDUCTIVITY (gpd/ft ²)	STORATIVITY	SPECIFIC CAPACITY(gpm/ft)	METHOD	DURATION (hours)	LITHOLOGY	START DATE	REFERENCE	COMMENTS
Fisk Well	3N2E6DDC1	850	569-589, 604-624, 639-660, 705-715	m	1500	pumping well	no	39,554	145	273	***	68.2	constant rate pump test, Jacobs Semi-log Drawdown Method	7	sand?	1/28/92	9	Aquifer parameters determined from pumping well
Market Well	3N2E35DAD1	944	460-470, 495-515, 600-610, 695-705, 725-735, 760-775, 804-814, 830-840, 892-902	s	1,500	no	no	40,000	440	91	***	40.0	constant rate pump test, Jacobs Semi-log Drawdown Method	8	sand?	5/28/91	10	Aquifer parameters determined from pumping well
HP Well	4N1E27ADC1	700	598-5-685	s	1,400	no	early	29,600	87	340	***	19.0	constant rate pump test, Jacobs Semi-log Drawdown Method	8	sand?	5/17/91	11	
HP Well	4N1E27ADC1	700	598-5-685	s	1,400	no	late	12,300	87	141	***	19.0	constant rate pump test, Jacobs Semi-log Drawdown Method	8	sand?	5/17/92	11	Low, late, T values suggest hydraulic barriers.

PUMPING WELL NAME	LOCATION	DEPTH OF PUMPING WELL (FT)	COMPLETION INTERVAL(FT)	Multiple or Single Well?	PUMPING RATE (gpm)	MULTIPLE WELLS	MULTIPLE TIMES	TRANS-MISSIVITY (gpd/ft)	Assumed Aquifer Thickness (ft)	HYDRAULIC CONDUCTIVITY (gpd/ft ²)	STORATIVITY	SPECIFIC CAPACITY(gpm/ft)	METHOD	DURATION (hours)	LITHOLOGY	START DATE	REFERENCE	COMMENTS
New Goddard Well	4N1E36BAC	551	475-545	s	1,714	yes	late	22,000	70	314	***	15.0	constant rate pump test, Jacobs Semi-log Drawdown Method	8	sand	2/28/91	12	Low, late, T values suggest hydraulic barriers.
Columbia Test Well	3N3E32CD D1	802	560-575, 628-638, 711-731	s	22	no	early	5,000	150	33	***	3.0	step-rate pump test, Jacobs Semi-log Drawdown Method	4	fine sand	10/5/90	13	Estimated long term yields less than 200gpm.
Columbia Test Well	3N3E32CD D1	802	560-575, 628-638, 711-731	s	40	no	middle	1,100	150	7	***	3.3	step-rate pump test, Jacobs Semi-log Drawdown Method	4	fine sand	10/5/90	13	
Columbia Test Well	3N3E32CD D1	802	560-575, 628-638, 711-731	s	88	no	late	500	150	3	***	2.1	step-rate pump test, Jacobs Semi-log Drawdown Method	4	fine sand	10/5/90	13	Low, late, T values suggest hydraulic barriers.
Cassia Well	3N2E16DAA1	590	215-241, 285-321, 357-367, 390-400	s	850	no	early	50,000	150	333	***	29.0	constant rate pump test, Jacobs Semi-log Drawdown Method	5.7	unknown	5/29/90	14	T values may have decreased with longer pump test.

PUMPING WELL NAME	LOCATION	DEPTH OF PUMPING WELL (FT)	COMPLETION INTERVAL(FT)	Multiple or Single Well?	PUMPING RATE (gpm)	MULTIPLE WELLS	MULTIPLE TIMES	TRANS-MISSIVITY (gpd/ft)	Assumed Aquifer Thickness (ft)	HYDRAULIC CONDUCTIVITY (gpd/ft ²)	STORATIVITY	SPECIFIC CAPACITY(gpm/ft)	METHOD	DURATION (hours)	LITHOLOGY	START DATE	REFERENCE	COMMENTS
Cassia Well	3NZE16DAA1	590	215-241, 285-321, 357-367, 390-400	s	850	no	late	40,000	150	267	***	29.0	constant rate pump test, Jacobs Semi-log Drawdown Method	5.7	unknown	5/29/90	14	T values may have decreased with longer pump test.
Bergeson Well	3NZE26DAB1	852	?	m	1200	pumping well	early	60,000	385	156	***	15.0	constant rate pump test, Jacobs Semi-log Drawdown Method	12	?	2/13/90	16	S.C. Determined from step-rate pump test.
Bergeson Well	3NZE26DAB1	852	?	m	1200	pumping well	late	25,000	385	65	***	15.0	constant rate pump test, Jacobs Semi-log Drawdown Method	12	?	2/13/90	16	S.C. Determined from step-rate pump test.
Bergeson Well	3NZE26DAB1	852	?	m	1200	obs. well 1	early	150,000	385	390	0.005	15.0	constant rate pump test, Jacobs Semi-log Drawdown Method	12	?	2/13/90	16	Storativity value is suspect.
Bergeson Well	3NZE26DAB1	852	?	m	1200	obs. well 1	late	60,000	385	156	0.005	15.0	constant rate pump test, Jacobs Semi-log Drawdown Method	12	?	2/13/90	16	Storativity value is suspect.
Bergeson Well	3NZE26DAB1	852	?	m	1200	obs. well 2	no	40,000	385	104	4E-04	15.0	constant rate pump test, Jacobs Semi-log Drawdown Method	12	?	2/13/90	16	

PUMPING WELL NAME	LOCATION	DEPTH OF PUMPING WELL (FT)	COMPLETION INTERVAL(FT)	Multiple or Single Well?	PUMPING RATE (gpm)	MULTIPLE WELLS	MULTIPLE TIMES	TRANS-MISSIVITY (gpd/ft)	Assumed Aquifer Thickness (ft)	HYDRAULIC CONDUCTIVITY (gpd/ft ²)	STORATIVITY	SPECIFIC CAPACITY(gpm/ft)	METHOD	DURATION (hours)	LITHOLOGY	START DATE	REFERENCE	COMMENTS
Bergeson Well	3N2E26DAB 1	852	?	m	1200	obs. well 3	no	40,000	385	104	2E-04	15.0	constant rate pump test, Jacobs Semi-log Drawdown Method	12	?	2/13/90	16	
Clinton Street Well	3N2E8CBB1	485	?	s	1500	pumping well	late	13,000			***	18.9	constant rate pump test, Jacobs Semi-log Drawdown Method	9	?	2/8/91	17	Short term S.C averaged 27 gpm/ft.
Yanke-Nicholson North Well	2N2E17AAD 1	880	537-692, 697-860	s	1500	pumping well	no	29,000	320	91	***	30.0	constant rate pump test, Jacobs Semi-log Drawdown Method	120	sand, clay, gravel	11/16/90	18	S.C. is suspect because of discrepancies in static water level.
J.R. Flat Test Well	2N2E2BBC2	567		s	725	pumping well	early	8,500					constant rate pump test, Jacobs Semi-log Drawdown Method	0.3		7/28/89	19	
J.R. Flat Test Well	2N2E2BBC2	567		s	815	pumping well	late	25,000					constant rate pump test, Jacobs Semi-log Drawdown Method	6		7/28/89	19	
New Long Meadow Well	3N2E713BC B1	415	123-401	m	1775	pumping well	early	62,000	278	223	***	32.0	constant rate pump test, Jacobs Semi-log Drawdown Method	12		3/14/89	20	Pumping well was determined to have high efficiency.

PUMPING WELL NAME	LOCATION	DEPTH OF PUMPING WELL (FT)	COMPLETION INTERVAL(FT)	Multiple or Single Well?	PUMPING RATE (gpm)	MULTIPLE WELLS	MULTIPLE TIMES	TRANS-MISSIVITY (gpd/ft)	Assumed Aquifer Thickness (ft)	COND-UCTIVITY (gpd/ft ²)	STORATIVITY	SPECIFIC CAPACITY(gpm/ft)	METHOD	DURATION (hours)	LITHOLOGY	START DATE	REFERENCE	COMMENTS
New Long Meadow Well	3NZE713BC B2	415	123-401	m	1775	pumping well	late	31,000	278	112	***	32.0	constant rate pump test, Jacobs Semi-log Drawdown Method	12		3/14/89	20	Pumping well was determined to have high efficiency.
New Long Meadow Well	3NZE713BC B3	415	123-401	m	1175	obs. well 2	no	43,000	278	155	***	32.0	constant rate pump test, Jacobs Semi-log Drawdown Method	12		3/14/89	20	Pumping well was determined to have high efficiency.
Swift No. 2 Well	4NZE30DC2			m	2200	pumping well	early	100,000			***	32	constant rate pump test, Jacobs Semi-log Drawdown Method	12		3/11/89	21	
Swift No. 2 Well	4NZE30DC2			m	2200	pumping well	middle	30,000			***	32	constant rate pump test, Jacobs Semi-log Drawdown Method	12		3/11/89	21	
Swift No. 2 Well	4NZE30DC2			m	2200	pumping well	late	15,000			***	32	constant rate pump test, Jacobs Semi-log Drawdown Method	12		3/11/89	21	
Swift No. 2 Well	4NZE30DC2			m	2200	obs. well	early	100,000			0.001	32	constant rate pump test, Jacobs Semi-log Drawdown Method	12		3/11/89	21	

PUMPING WELL NAME	LOCATION	DEPTH OF PUMPING WELL (FT)	COMPLETION INTERVAL(FT)	Multiple or Single Well?	PUMPING RATE (gpm)	MULTIPLE WELLS	MULTIPLE TIMES	TRANS-MISSIVITY (gpd/ft)	Assumed Aquifer Thickness (ft)	HYDRAULIC COND-UCTIVITY (gpd/ft ²)	STORATIVITY	SPECIFIC CAPACITY(gpm/ft)	METHOD	DURATION (hours)	LITHOLOGY	START DATE	REFERENCE	COMMENTS
Swift No. 2 Well	4NZE30DC2			m	2200	obs. well	middle	35,000			0.001	32	constant rate pump test, Jacobs Semi-log Drawdown Method	12		3/11/89	21	
Londoner Well	3NZE?23BA A1	?1200		s	55	pumping well	early-deep zone (810-875)	8,500	65	131	***	***	step rate pump test, Jacobs Semi-log Drawdown Method	6		9/8/88	22	Late, low T values likely due to aquifer thinning.
Londoner Well	3NZE?23BA A1	?1200		s	140	pumping well	late-deep zone (810-875)	2,500	65	38	***	***	step rate pump test, Jacobs Semi-log Drawdown Method	6		9/8/88	22	Late, low T values likely due to aquifer thinning.
Londoner Well	3NZE?23BAA 1	?1200		s	35	pumping well	early-intermediate zone (650-750)	5,000	100	50	***	***	step rate pump test, Jacobs Semi-log Drawdown Method	4.5		9/2/88	22	Low amount of drawdown likely due to upper zone leakage.
Londoner Well	3NZE?23BAA 1	?1200		s	135	pumping well	late-intermediate zone (650-750)	5,000	100	50	***	***	step rate pump test, Jacobs Semi-log Drawdown Method	4.5		9/2/88	22	Low amount of drawdown likely due to upper zone leakage.
Londoner Well	3NZE?23BAA 1	?1200		s	82	pumping well	early-upper zone (220-550)	10,000	330	30	***	***	step rate pump test, Jacobs Semi-log Drawdown Method	4		8/19/88	22	

PUMPING WELL NAME	LOCATION	DEPTH OF PUMPING WELL (FT)	COMPLETION INTERVAL(FT)	Multiple or Single Well?	PUMPING RATE (gpm)	MULTIPLE WELLS	MULTIPLE TIMES	TRANS-MISSIVITY (gpd/ft)	Assumed Aquifer Thickness (ft)	HYDRAULIC COND-UCTIVITY (gpd/ft ²)	STORATIVITY	SPECIFIC CAPACITY(gpm/ft)	METHOD	DURATION (hours)	LITHOLOGY	START DATE	REFERENCE	COMMENTS
River Run Well	3N2E24DB D2	485	198-480	m	1880	pumping well	early	50,000			***		step rate pump test, Jacobs Semi-log Drawdown Method	11		3/11/88	23	Third step of test was used as constant rate pump test (9.5 hours).
River Run Well	3N2E24DB D2	485	198-480	m	1880	pumping well	middle	25,000			***		step rate pump test, Jacobs Semi-log Drawdown Method	11		3/11/88	23	Third step of test was used as constant rate pump test (9.5 hours).
River Run Well	3N2E24DB D2	485	198-480	m	1880	pumping well	late	5,000			***		step rate pump test, Jacobs Semi-log Drawdown Method	11		3/11/88	23	Third step of test was used as constant rate pump test (9.5 hours).
River Run Well	3N2E24DB D2	485	198-480	m	1880	obs. well 1 (100ft)	no	10,000			0.03		step rate pump test, Jacobs Semi-log Drawdown Method	11		3/11/88	23	Third step of test was used as constant rate pump test (9.5 hours).
River Run Well	3N2E24DB D2	485	198-480	m	1880	obs. well 2 (Logger well)	no	7,500			5E-05		step rate pump test, Jacobs Semi-log Drawdown Method	11		3/11/88	23	Third step of test was used as constant rate pump test (9.5 hours).
River Run Well	3N2E24DB D2	485	198-480	M	1880	obs. well 3 (Long Meadow Well)	no	6,000			3E-05		step rate pump test, Jacobs Semi-log Drawdown Method	11		3/11/88	23	Third step of test was used as constant rate pump test (9.5 hours).

PUMPING WELL NAME	LOCATION	DEPTH OF PUMPING WELL (FT)	COMPLETION INTERVAL(FT)	Multiple or Single Well?	PUMPING RATE (gpm)	MULTIPLE WELLS	MULTIPLE TIMES	TRANS-MISSIVITY (gpd/ft)	Assumed Aquifer Thickness (ft)	HYDRAULIC CONDUCTIVITY (gpd/ft ²)	STORATIVITY	SPECIFIC CAPACITY(gpm/ft)	METHOD	DURATION (hours)	LITHOLOGY	START DATE	REFERENCE	COMMENTS
Hidden Hollow Landfill EW-2		58	32-52	m	45	pumping well	no	5,400	18	300	***	10.1	constant rate pump-bailer test, Neuman Method	2.5	fine sand to course sand	4/24/97	25	Pumping rate is based on an average of variable pumping rates.
Hidden Hollow Landfill EW-2		58	32-53	m	45	obs. well1(10ft)	no	10,900	17	641	0.05	10.1	constant rate pump-bailer test, Nueman Method	2.5	fine sand to course sand	4/24/97	25	Pumping rate is based on an average of variable pumping rates.
Hidden Hollow Landfill EW-2		58	32-54	m	45	obs. well 2 (160ft)	no	24,400	22	1,109	0.1	10.1	constant rate pump-bailer test, Nueman Method	2.5	fine sand to course sand	4/24/97	25	Pumping rate is based on an average of variable pumping rates.
Hidden Hollow Landfill EW-3		98	50-70	m	45	pumping well	no	4,300	22	195	***	8.2	constant rate pump-bailer test, Nueman Method	2	fine sand to course sand	4/22/97	25	Pumping rate is based on an average of variable pumping rates.
Hidden Hollow Landfill EW-3		98	50-71	m	45	obs. well 1 (9ft)	no	10,700	22	486	0.04	8.2	constant rate pump-bailer test, Nueman Method	2	fine sand to course sand	4/22/97	25	Pumping rate is based on an average of variable pumping rates.
Hidden Hollow Landfill EW-3		98	50-72	m	45	obs. well 2 (136ft)	no	19,300	21	919	0.1	8.2	constant rate pump-bailer test, Nueman Method	2	fine sand to course sand	4/22/97	25	Pumping rate is based on an average of variable pumping rates.

PUMPING WELL NAME	LOCATION	DEPTH OF PUMPING WELL (FT)	COMPLETION INTERVAL(FT)	Multiple or Single Well?	PUMPING RATE (gpm)	MULTIPLE WELLS	MULTIPLE TIMES	TRANS-MISSIVITY (gpd/ft)	Assumed Aquifer Thickness (ft)	HYDRAULIC COND-UCTIVITY (gpd/ft ²)	STORATIVITY	SPECIFIC CAPACITY(gpm/ft)	METHOD	DURATION (hours)	LITHOLOGY	START DATE	REFERENCE	COMMENTS
Hidden Hollow Landfill EW-4		78	51-71	m	45	pumping well	no	2,100	20	105	***	4.7	constant rate pump-bailer test, Nueman Method	1	fine sand to course sand	4/28/97	25	Pumping rate is based on an average of variable pumping rates.
Hidden Hollow Landfill EW-4		78	51-72	m	45	obs. well 1 (12ft)	no	4,200	21	200	0.06	4.7	constant rate pump-bailer test, Nueman Method	1	fine sand to course sand	4/28/97	25	Pumping rate is based on an average of variable pumping rates.
Hidden Hollow Landfill EW-4		78	51-73	m	45	obs. well 2 (80)	no	21,000	22	955	0.002	4.7	constant rate pump-bailer test, Nueman Method	1	fine sand to course sand	4/28/97	25	Pumping rate is based on an average of variable pumping rates.
Allied Seed Coop MW-1	3N2W	21.5	5.0-20.0	s	6	pumping well	no	1,491	11.5	130	***	3.8	constant rate pump test, Jacobs Semi-log Drawdown Method	1	fine sand	7/16/91	26	Short duration pump test with recovery data.
Mark Lynn Stock Water Well	5N1W	429	165-300	m	172	pumping well	no	77,000	135	570	***	***	water level recovery test, Jacobs Semi-log Drawdown Method	120	sand and gravel	10/17/94	27	Domestic pump was pumping intermittently during test.
Mark Lynn Stock Water Well	5N1W	429	165-300	m	172	obs. well (275ft)	no	108,000	135	800	0.01	***	water level recovery test, Jacobs Semi-log Drawdown Method	120	sand and gravel	10/17/95	27	Domestic pump was pumping intermittently during test.

PUMPING WELL NAME	LOCATION	DEPTH OF PUMPING WELL (FT)	COMPLETION INTERVAL(FT)	Multiple or Single Well?	PUMPING RATE (gpm)	MULTIPLE WELLS	MULTIPLE TIMES	TRANS-MISSIVITY (gpd/ft)	Assumed Aquifer Thickness (ft)	HYDRAULIC CONDUCTIVITY (gpd/ft ²)	STORATIVITY	SPECIFIC CAPACITY(gpm/ft)	METHOD	DURATION (hours)	LITHOLOGY	START DATE	REFERENCE	COMMENTS
Westpark Commercial Center Well 9		45	25-45	m	?	pumping well	no	143,100	30	4,770	0.03	***	***	10	gravel	9/1988	28	Several monitoring wells are located at the site.
N. Fivemile Extraction Well FMEW-2		67	12.0-65.0	m	82	pumping well	late	86,730	23	3,771	0.115	1.5	constant rate pump test, Jacobs Semi-log Drawdown Method	24	gravel	11/16/95	29	Some fluctuation in Q was noted. Specific capacity value is likely attributed to 10% well efficiency.
N. Fivemile Extraction Well FMEW-2		67	12.0-65.0	m	82	obs. well 1 (125)	early	696,388	23	30,278	0.009	1.5	constant rate pump test, Jacobs Semi-log Drawdown Method	24	gravel	11/16/95	29	Some fluctuation in Q was noted. Specific capacity value is likely attributed to 10% well efficiency.
N. Fivemile Extraction Well FMEW-2		67	12.0-65.0	m	82	obs. well 1 (125)	late	111,751	23	4,859	0.185	1.5	constant rate pump test, Jacobs Semi-log Drawdown Method	24	gravel	11/16/95	29	Some fluctuation in Q was noted. Specific capacity value is likely attributed to 10% well efficiency.

PUMPING WELL NAME	LOCATION	DEPTH OF PUMPING WELL (FT)	COMPLETION INTERVAL(FT)	Multiple or Single Well?	PUMPING RATE (gpm)	MULTIPLE WELLS	MULTIPLE TIMES	TRANS-MISSIVITY (gpd/ft)	Assumed Aquifer Thickness (ft)	HYDRAULIC CONDUCTIVITY (gpd/ft ²)	STORATIVITY	SPECIFIC CAPACITY(gpm/ft)	METHOD	DURATION (hours)	LITHOLOGY	START DATE	REFERENCE	COMMENTS
N. Fivemile Extraction Well FMEW-2		67	12.0-65.0	m	82	obs. well 2 (157)	early	404,668	23	17,594	0.006	1.5	constant rate pump test, Jacobs Semi-log Drawdown Method	24	gravel	11/16/95	29	Some fluctuation in Q was noted. Specific capacity value is likely attributed to 10% well efficiency.
N. Fivemile Extraction Well FMEW-2		67	12.0-65.0	m	82	obs. well 2 (157)	late	123,644	23	5376	0.053	1.5	constant rate pump test, Jacobs Semi-log Drawdown Method	24	gravel	11/16/95	29	Some fluctuation in Q was noted. Specific capacity value is likely attributed to 10% well efficiency.
N. Fivemile Extraction Well FMEW-2		67	12.0-65.0	m	82	obs. well 3 (168))	late	169,870	23	7386	0.027	1.5	constant rate pump test, Jacobs Semi-log Drawdown Method	24	gravel	11/16/95	29	Some fluctuation in Q was noted. Specific capacity value is likely attributed to 10% well efficiency.
N. Fivemile Extraction Well FMEW-2		67	12.0-65.0	m	82	obs. well 4 (335)	early	***	23	***	***	1.5	constant rate pump test, Jacobs Semi-log Drawdown Method	24	gravel	11/16/95	29	Some fluctuation in Q was noted. Specific capacity value is likely attributed to 10% well efficiency.

PUMPING WELL NAME	LOCATION	DEPTH OF PUMPING WELL (FT)	COMPLETION INTERVAL(FT)	Multiple or Single Well?	PUMPING RATE (gpm)	MULTIPLE WELLS	MULTIPLE TIMES	TRANS-MISSIVITY (gpd/ft)	Assumed Aquifer Thickness (ft)	HYDRAULIC CONDUCTIVITY (gpd/ft ²)	STORATIVITY	SPECIFIC CAPACITY(gpm/ft)	METHOD	DURATION (hours)	LITHOLOGY	START DATE	REFERENCE	COMMENTS
N. Fivemile Extraction Well FMEW-2		67	12.0-65.0	m	82	obs. well 4 (335)	late	165,981	23	7217	0.079	1.5	constant rate pump test, Jacobs Semi-log Drawdown Method	24	gravel	11/16/95	29	Some fluctuation in Q was noted. Specific capacity value is likely attributed to 10% well efficiency.
Caldwell Geothermal Well 1				m	1000	obs. well	no	10,472	23	455	2E-04	38.5	water level recovery test, Theis Drawdown Test Method	3.9	?	8/23/89	30	5 aquifer test periods were completed
Oregon Trail Well	3N3E	838				pumping well		9,000	800	11	***		constant rate pump test, Theis Drawdown Test Method	720		1/13/92	31	
Terteling Production Well	3N2E	642	342-632			obs. well		31,000	300	103	2E-04		constant rate pump test, Theis Drawdown Test Method	720		1/13/92		
Centennial Production Well	3N2E	416				obs. well		31,000	800	39	2E-04		water level recovery test, Theis Drawdown Test Method	720		1/13/92	31	Observation well for Oregon Trail 30 day pump test

PUMPING WELL NAME	LOCATION	DEPTH OF PUMPING WELL (FT)	COMPLETION INTERVAL(FT)	Multiple or Single Well?	PUMPING RATE (gpm)	MULTIPLE WELLS	MULTIPLE TIMES	TRANS-MISSIVITY (gpd/ft)	Assumed Aquifer Thickness (ft)	HYDRAULIC COND-UCTIVITY (gpd/ft ²)	STORATIVITY	METHOD	DURATION (hours)	LITHOLOGY	START DATE	REFERENCE	COMMENTS
Gowen Production Well	2N2E	702	375-507			obs. well		45,000	125	360	0.001	water level recovery test, Theis Drawdown Test Method	720		1/13/92	31	Observation well for Oregon Trail 30 day pump test
Micron Test Well	2N3E	855	629-845			obs. well		480,000	215	2,233	0.002	water level recovery test, Theis Drawdown Test Method	720		1/13/92	31	Observation well for Oregon Trail 30 day pump test
Columbia Test Well	3N3E	802				obs. well		30,000	800	38	0.003	water level recovery test, Theis Drawdown Test Method				31	Observation well for Oregon Trail 30 day pump test
Canyon Co Drainage District No. 4	5N4W28CC1				1030						0.025				6/53	32	
Pioneer Irrigation District	4N3W25DA1				1550					5,000	0.004				10/53	32	
Pioneer Irrigation District	4N3W3BB1				2110					23,000	0.23				11/53	32	

PUMPING WELL NAME	LOCATION	DEPTH OF PUMPING WELL (FT)	COMPLETION INTERVAL(FT)	Multiple or Single Well?	PUMPING RATE (gpm)	MULTIPLE WELLS	MULTIPLE TIMES	TRANS-MISSIVITY (gpd/ft)	Assumed Aquifer Thickness (ft)	HYDRAULIC CONDUCTIVITY (gpd/ft ²)	STORATIVITY	SPECIFIC CAPACITY(gpm/ft)	METHOD	DURATION (hours)	LITHOLOGY	START DATE	REFERENCE	COMMENTS
Pioneer Irrigation District	3N3W11DA1				2,175					25,000	0.006					10/53	32	
Pioneer Irrigation District	3N2W8CC1				1,480						0.0006					10/53	32	
Amalgamated Sugar	3N2W9DD4				1,830					5,900	0.0001					2/53	32	
Pioneer Irrigation District	3N1W7BB1				1,060					3,700	0.003					11/53	32	
US Bureau of Reclamation	2N1W7BC4				2,900					18,000	0.004					9/53	32	
State Fish Hatchery	4N1W13DC1				480					300						3/51	32	

PUMPING WELL NAME	LOCATION	DEPTH OF PUMPING WELL (FT)	COMPLETION INTERVAL(FT)	Multiple or Single Well?	PUMPING RATE (gpm)	MULTIPLE WELLS	MULTIPLE TIMES	TRANS-MISSIVITY (gpd/ft)	Assumed Aquifer Thickness (ft)	HYDRAULIC COND-UCTIVITY (gpd/ft ²)	STORATIVITY	SPECIFIC CAPACITY(gpm/ft)	METHOD	DURATION (hours)	LITHOLOGY	START DATE	REFERENCE	COMMENTS
State Fish Hatchery	4N1W13DC2				600					660	0.001					3/51	32	
US Bureau of Reclamation	3N1E5AB1				125					900	0.001					11/53	32	
US Bureau of Reclamation	3N1E5AB1				600					2,400	0.006					11/53	32	
M.S. Ayres	3N1E36AD2				980					1,500	0.00007					9/53	32	
Ada Co Drainage District No. 2	3N2E25BB1				1,380					2,500	0.43					11/53	32	

References for Aquifer Test Data

1. Montgomery, J. M., Sept. 1992, New Playground Well, City of Boise Project Closeout Report, JMM, Boise, Idaho.
2. Montgomery, J. M., Sept. 1992, New Diamond Well, City of Boise Project Closeout Report, JMM, Boise, Idaho.
3. CH2M Hill, June 1991, Results of The 30-Day Pumping Test and Aquifer Analysis Report, Prepared For Floating Hills, Inc., Boise, Idaho.
4. Anderson & Kelly Consultants, July 1992, Effects Of Pumping Boise Water Corporation Broadway Well Report, Prepared for Boise Water Corporation, Boise, Idaho.
5. Scanlan, T. M., June 3, 1994, Personnel memorandum to Mr. Gary Madenford—Redwood Creek Subdivision Well No.1 Report, Scanlan Engineering, Boise, Idaho.
6. Anderson, K. E., October 1962, Willow Lane Well Field Report, Prepared for Boise Water Corporation, Boise, Idaho.
7. Dittus, R., June 6, 1996, United Water Idaho Veterans Well Fact Sheet, United Water, Boise, Idaho.
8. Dittus, R., June 6, 1996, United Water Idaho Gary Lane Well Fact Sheet, United Water, Boise, Idaho.
9. Naylor, P. N., February 1992, Boise Water Corporation Well Tests 1987–1992, Scanlan Engineering, Boise, Idaho.
10. Scanlan, T. M., June 24, 1991, Boise Water Corporation Well Tests 1987–1992, Scanlan Engineering, Boise, Idaho.
11. Mills, D. E., May 30, 1991, Boise Water Corporation Well Tests 1987–1992, Scanlan Engineering, Boise, Idaho.
12. Mills, D. E., March 14, 1991, Boise Water Corporation Well Tests 1987–1992, Scanlan Engineering, Boise, Idaho.
13. Mills, D. E., October 24, 1990, Boise Water Corporation Well Tests 1987–1992, Scanlan Engineering, Boise, Idaho.
14. Scanlan, T. M., June 18, 1990, Boise Water Corporation Well Tests 1987–1992, Scanlan Engineering, Boise, Idaho.
15. Scanlan, T. M., April 30, 1990, Boise Water Corporation Well Tests 1987–1992, Scanlan Engineering, Boise, Idaho.
16. Scanlan, T. M., February 28, 1990, Boise Water Corporation Well Tests 1987–1992, Scanlan Engineering, Boise, Idaho.
17. Scanlan, T. M., February 16, 1990, Boise Water Corporation Well Tests 1987–1992, Scanlan Engineering, Boise, Idaho.

18. Scanlan, T. M., February 16, 1990, Boise Water Corporation Well Tests 1987–1992, Scanlan Engineering, Boise, Idaho.
19. Scanlan, T. M., July 28, 1989, J. R Flat Well Test, Boise Water Corporation Well Tests 1987–1992, Scanlan Engineering, Boise, Idaho.
20. Scanlan, T. M., April 6, 1989, Testing of the New Long Meadow Well, Boise Water Corporation Well Tests 1987–1992, Scanlan Engineering, Boise, Idaho.
21. Scanlan, T. M., April 6, 1989, Testing of Swift Well No. 2, Boise Water Corporation Well Tests 1987–1992, Scanlan Engineering, Boise, Idaho.
22. Scanlan, T. M., September 19, 1989, Londoner Well–Deep Zone Test, Boise Water Corporation Well Tests 1987–1992, Scanlan Engineering, Boise, Idaho.
23. Scanlan, T. M., April 4 1988, River Run Well Test Summary, Boise Water Corporation Well Tests 1987–1992, Scanlan Engineering, Boise, Idaho.
24. Mikels, F. C., November 7, 1952, Report on Hydrogeological Survey for Boise Water Corporation, Ranney Method Water Supplies, Inc., Boise, Idaho.
25. CH2M Hill, Inc., March 1998, Well Construction and Hydrogeological Characterization of the Groundwater Remediation Site Ada County Landfill, Boise, Idaho.
26. Backe, M. A., June 13, 1991, Personnel memorandum to Craig Ranke of Sweet Edwards/EMCON, Inc., Special Resource Management, Boise, Idaho.
27. Scanlan, T. M., February 16, 1990, Personnel memorandum to Ms. Dana Hofstetter–Aquifer Test Results for Mark Lynn Ranch on Willow Creek, Scanlan Engineering, Boise, Idaho.
28. Special Resource Management, January 13, 1989, Groundwater Remedial Action Plan for the Westpark Commercial Center, Boise, Idaho.
29. Taraszki, R. G., March 15, 1996, Results of Aquifer Testing and Preliminary Capture Analysis North Five Mile Road Area Groundwater Extraction System, Harding Lawson Associates, Boise, Idaho.
30. Ralston, D. R., October 1989, Analysis of August 1989 Aquifer Tests, Caldwell Geothermal Wells, Prepared for J. R. Simplot Co., Moscow, Idaho.
31. Squires, E., Wood, S. H., Osiensky, J. L., and Dittus, R. D., October 1993, Groundwater Conditions and Hydraulic Testing of the Boise Fan Aquifer of Southeast Boise River Valley, Ada County, Idaho.
32. Nace, R. L., West, S. W., and Mower, R. W. 1957. Feasibility of Ground-Water Features of the Alternate Plan for the Mountain Home Project Idaho. U.S. Geological Survey Water Supply Paper 1376.

Appendix C. CONSTRUCTION DETAILS FOR DEDICATED, MULTI-LEVEL PIEZOMETERS

*** Construction diagrams for TVHP monitoring wells provided under separate cover. ***

Appendix D. CONSTRUCTION AND MEASUREMENT DETAILS FOR MASS MEASUREMENT WELLS

Well Name	Site ID	Well Latitude	Well Longitude	Surface Elevation	Use	Open Interval	Well Depth	1996 Spring	1996 Fall	1998 Spring	1998 Fall	2000 Spring	2000 Fall	2001 Fall
01N 01E 03CCC1	432644116195401	43.44556	-116.3317	2782	I	27-288	288	X	X	X	X	X	X	X
01N 01E 05CCD1	432641116221201	43.44473	-116.37	2817	I	279-440	440	X	X	X		X	X	
01N 01E 12DAA1	432613116162901	43.43695	-116.2747	2860	U	232-312	322	X	X					
01N 01E 16ACC1	432525116203301	43.42361	-116.3425	2820	H	38-386	386	X	X	X	X	X	X	X
01N 01E 19ADB1	432442116223901	43.41167	-116.3775	2880	I	18-440	440	X	X	X	X	X	X	X
01N 01E 25DBA1	432336116164601	43.39333	-116.2794	2849	I	36-530	530	X						
01N 01E 33AAD1	432301116200401	43.38361	-116.3344	2865	I	19-618	618			X	X	X	X	X
01N 01W 01BDB1	432717116242501	43.45472	-116.4069	2800	I	183-325	401			X		X	X	X
01N 01W 02ADC1	432707116250501	43.45195	-116.4181	2850	I	245-455	455	X						
01N 01W 07BCC1	432618116304401	43.43834	-116.5122	2820	I	14-408	408			X	X	X	X	
01N 01W 07CAB1	432613116302601	43.43695	-116.5072	2780	I	12-461	461	X						
01N 01W 07DBB1	432613116300901	43.4375	-116.5028	2800	I	18-591	591		X					
01N 01W 15DAA1	432520116260401	43.42222	-116.4344	2890	I	293-541	541	X						
01N 01W 18CCC1	432500116303901	43.41667	-116.5108	2730	H	484-520	520			X	X	X	X	X
01N 01W 22DDD1	432407116260001	43.40195	-116.4333	2888	I	345-502	502			X	X	X	X	
01N 01W 24AAA1	432452116234201	43.41445	-116.395	2880	I	20-366	366	X	X	X	X	X		
01N 01W 27ADD1	432344116255901	43.39556	-116.4331	2904	U/I	18-365	500	X	X	X	X	X	X	X
01N 01W 30AAD1	432351116293701	43.3975	-116.4936	2740	I	21-415	415			X	X	X	X	X
01N 02E 04BBA1	432729116134201	43.45806	-116.2283	3005	I/M	488-615	625	X	X	X				
01N 02E 06BAA1	432732116155501	43.45889	-116.2653	2910	I/U	448-510	535	X	X	X	X	X	X	X
01N 02E 08ADA2	432620116140102	43.43889	-116.2336	2930	H	375-400	400	X	X	X	X	X	X	
01N 02W 04DDC1	432645116343001	43.44584	-116.575	2700	I	450-685	685	X	X	X	X	X	X	X
01N 02W	432708116353901	43.45222	-116.5942	2675	I	415-720	720	X	X	X	X	X	X	X

Well Name	Site ID	Well Latitude	Well Longitude	Surface Elevation	Use	Open Interval	Well Depth	1996 Spring	1996 Fall	1998 Spring	1998 Fall	2000 Spring	2000 Fall	2001 Fall
05ADD1														
01N 02W 06ADD1	432709116365101	43.4525	-116.6142	2728	I	596-720	720	X	X	X		X	X	X
01N 02W 09DDD2	432554116342101	43.43167	-116.5725	2665	H	-	252	X	X	X	X	X	X	X
01N 02W 10DAA1	432613116331001	43.43695	-116.5528	2660	H	19-150	150	X	X	X	X	X	X	X
01N 02W 17DDA1	432510116353301	43.41945	-116.5925	2718	I	370-565	565	X	X	X	X			
01N 02W 35CDB1	432232116330401	43.37555	-116.5511	2600	H	35-213	213			X	X	X	X	X
01N 03W 02CCB1	432652116401701	43.44778	-116.6714	2730	H	500-1000	1000			X	X	X	X	X
01N 03W 03DDD1	432646116402101	43.44611	-116.6725	2715	H	331-731	731	X	X	X	X	X	X	X
01N 03W 06DDC1	432640116440701	43.44445	-116.7353	2240	H	416-560	560	X	X	X	X	X	X	X
01N 03W 13AAA1	432548116375701	43.43	-116.6325	2688	I	220-607	607	X	X	X	X	X	X	X
01N 03W 25AAA1	432403116375601	43.40083	-116.6322	2740	H	599-710	710			X	X	X	X	X
01N 04E 13CCCB1	432500115560301	43.41667	-115.9342	3530	H	38-110	110	X	X					
01N 04E 28CAC1	432326115591601	43.39167	-115.9889	3360	N	500-752	763	X	X			X	X	X
01N 05E 17BAB1	432539115532201	43.4275	-115.8894	3660	U	53-68	82	X	X					
01S 01W 05BAC1	432209116282501	43.36916	-116.4736	2738	I	9-370	370			X	X	X	X	X
01S 01W 19AAB1	431944116294401	43.32889	-116.4956	2615	I	225-383	388			X	X	X	X	
01S 01W 29CBC1	431816116292801	43.30444	-116.4911	2575	I	200-282	295			X	X	X	X	
01S 01W 29CBD1	431816116291401	43.30444	-116.4872	2590	I	259-279	300			X	X	X	X	
01S 01W 30AAB1	431848116295001	43.31333	-116.4972	2543	H	299-400	400			X	X	X	X	
01S 01W 30BAB1	431851116301101	43.31417	-116.5031	2512	H	198-300	300		X	X	X	X	X	X
01S 02W 03DBC1	432147116333601	43.36305	-116.56	2410	H	32-44	44	X	X	X				
01S 02W 08DCD1	432040116354701	43.34444	-116.5964	2350	H	120-170	180			X	X	X	X	X
01S 02W 13ABBC1	432031116311201	43.34194	-116.52	2530	H	137-183	183			X	X	X	X	

Well Name	Site ID	Well Latitude	Well Longitude	Surface Elevation	Use	Open Interval	Well Depth	1996 Spring	1996 Fall	1998 Spring	1998 Fall	2000 Spring	2000 Fall	2001 Fall
01S 02W 13ABBC2	432031116311202	43.34194	-116.52	2530	H	18-300	300			X	X	X	X	X
01S 02W 14CCC2	431948116330001	43.33	-116.55	2395	H	-	235	X	X	X	X	X	X	X
01S 02W 15ABA1	432037116332101	43.34361	-116.5558	2450	H	220-420	420			X	X	X	X	X
01S 02W 24CBA1	431917116313301	43.32139	-116.5258	2490	I	127-190	190		X	X	X	X	X	X
01S 04E 03ADB1	432202115573001	43.36722	-115.9583	3375	U	-	530	X	X	X	X	X	X	X
02N 01E 01BCBC1	433230116173301	43.54167	-116.2925	2739	H	-	145	X	X	X	X	X	X	
02N 01E 02BACB1	433242116182601	43.545	-116.3072	2729	I	169-184	184	X	X	X	X	X	X	X
02N 01E 05CBDC1	433220116222001	43.53583	-116.3708	2735	H	236-242	242	X	X	X				
02N 01E 07CBBC1	433124116233501	43.52361	-116.3917	2670	H/I	135-145	145	X	X	X	X	X	X	
02N 01E 08ACC1	433129116214401	43.52472	-116.3622	2728	H	254-260	260	X	X	X	X	X	X	
02N 01E 12CDB1	433127116170101	43.52083	-116.2867	2885	H	-	290	X	X	X	X	X	X	
02N 01E 15ABA1	433101116191301	43.51694	-116.3203	2766	H	240-243	243	X	X	X	X			
02N 01E 22DCA1	432931116190701	43.49194	-116.3186	2836	I	360-440	444	X	X					
02N 01E 23BAD1	432959116181601	43.49972	-116.3045	2910	I	332-382	386	X	X	X	X			
02N 01E 26BBC1	432911116184601	43.48639	-116.3128	2840	H	298-300	300	X	X	X	X	X	X	
02N 01E 29BDB1	432915116222001	43.48417	-116.3678	2730	H	19-215	215			X	X	X	X	X
02N 01E 29DCA1	432834116213801	43.47611	-116.3606	2742	H	19-130	130	X	X	X	X	X	X	
02N 01E 31DDC1	432734116223901	43.45945	-116.3775	2748	H	225-248	248	X	X	X	X	X	X	X
02N 01E 33CAC1	432748116205201	43.46333	-116.3478	2758	H	16-224	224	X	X	X	X	X	X	X
02N 01E 33CCA2	432746116210202	43.46278	-116.3506	2752	H	-	0	X	X					
02N 01E 35BBC1	432822116183801	43.47278	-116.3106	2825	I	230-340	340	X	X	X	X	X	X	X
02N 01E 36BBB1	432825116173501	43.47361	-116.2931	2867	S/U	300-305	305	X	X	X	X	X	X	X
02N 01W	433246116255401	43.54611	-116.4317	2658	H	100-104	104	X	X	X	X	X	X	X

Well Name	Site ID	Well Latitude	Well Longitude	Surface Elevation	Use	Open Interval	Well Depth	1996 Spring	1996 Fall	1998 Spring	1998 Fall	Spring	2000 Fall	2001 Fall
02BBA1														
02N 01W 03ABB1	433246116262701	43.54611	-116.4408	2650	H	299-306	306	X	X	X	X	X	X	X
02N 01W 07AAB1	433155116294401	43.53194	-116.4956	2570	H	30-126	126			X		X	X	X
02N 01W 07BBC1	433145116304301	43.52917	-116.5119	2548	H	98-102	103	X	X	X	X	X	X	X
02N 01W 08BBBA1	433155116292501	43.53194	-116.4903	2570	H	33-94	94			X	X	X	X	X
02N 01W 09ADA1	433140116271401	43.52778	-116.4539	2600	H	-	37	X	X	X	X	X	X	X
02N 01W 09ADA2	433140116271402	43.52778	-116.4539	2600	U	192-197	197			X	X		X	X
02N 01W 10ABB1	433155116263101	43.53194	-116.4419	2640	H	128-130	130	X	X	X	X	X	X	X
02N 01W 11ADA1	433143116245101	43.52861	-116.4142	2685	I	64-130	190	X	X	X	X	X	X	X
02N 01W 12BAA1	433154116242601	43.53167	-116.4072	2675	H	93-95	95	X	X	X	X	X	X	X
02N 01W 13BAB1	433102116242301	43.51722	-116.4064	2683	H	-	96	X	X	X	X	X	X	X
02N 01W 15ADC1	433038116261201	43.51056	-116.4367	2675	H	95-96	96	X	X					
02N 01W 23ACC1	432946116251401	43.49611	-116.4206	2691	H	-	110	X	X	X	X	X	X	
02N 01W 27BCC1	432853116270901	43.48139	-116.4525	2689	H	400-410	410	X	X	X	X	X	X	X
02N 01W 29DCC1	432828116285001	43.47445	-116.4806	2670	H	242-250	250			X	X	X	X	X
02N 01W 32CBB1	432757116292601	43.46584	-116.4906	2685	I	150-234	240	X	X	X	X	X	X	X
02N 01W 35BDC1	432800116253901	43.46667	-116.4275	2790	I	155-210	218	X	X	X	X	X	X	X
02N 02E 01BAB1	433244116095501	43.54556	-116.1653	2921	P	375-507	702			X	X	X		
02N 02E 02BBC1	433235116112801	43.54306	-116.1911	2915	U	114-805	805	X	X					
02N 02E 02BBC2	433233116113201	43.5425	-116.1922	2911	P/P	435-500	567						X	X
02N 02E 04CAA1	433216116132201	43.53778	-116.2228	2887	I	-	0					X	X	X
02N 02E 04CBA1	433218116134201	43.53833	-116.2283	2884	I	300-400	555					X	X	
02N 02E 04CBB1	433218116135301	43.53889	-116.2319	2880	H/S	332-353	353	X	X	X	X	X	X	X

Well Name	Site ID	Well Latitude	Well Longitude	Surface Elevation	Use	Open Interval	Well Depth	1996 Spring	1996 Fall	1998 Spring	1998 Fall	Spring	2000 Fall	2001 Fall
02N 02E 06CCC1	433157116162301	43.5325	-116.2731	2768	H	-	0		X	X	X	X	X	X
02N 02E 06CCC2	433200116162001	43.53333	-116.2722	2770	H	185-195	195	X	X					
02N 02E 07CBC1	433119116161601	43.52195	-116.2711	2920	H	448-460	460	X	X	X	X	X	X	X
02N 02E 08AAD1	433144116135801	43.52889	-116.2328	2873	I	362-640	640	X	X					
02N 02E 12AAC1	433143116092001	43.52833	-116.1531	3035	H	417-503	503	X	X	X	X			
02N 02E 17AAD1	433050116140301	43.51389	-116.2342	3139	I	537-860	880	X	X					
02N 02E 21BAB1	433007116133501	43.50195	-116.2264	3142	I/H	523-800	800	X	X					
02N 02E 22BBB1	IDWR-S2000-01	43.50195	-116.2083	3175	P	691-912	930			X		X	X	X
02N 02E 31BCA1	432812116161401	43.47	-116.2706	2920	H	294-395	401	X	X	X	X	X	X	
02N 02E 32DBA1	432753116141901	43.46472	-116.2386	2985	I	492-559	564	X	X					
02N 02E 34CCD1	432732116123401	43.45889	-116.2094	3040	H	484-504	504	X	X	X	X	X	X	X
02N 02W 02CACC1	433211116324401	43.53639	-116.5456	2550	H	20-73	73	X	X	X	X	X	X	X
02N 02W 05ABA1	433243116355401	43.545	-116.5981	2555	H	178-180	180	X	X	X	X	X	X	X
02N 02W 07CBC1	433116116375501	43.52111	-116.6319	2555	H	-	122	X	X	X	X	X	X	X
02N 02W 09ACC1	433132116345001	43.52555	-116.5806	2602	P	178-194	194	X	X	X	X	X	X	
02N 02W 10CAA2	433128116335001	43.52444	-116.5639	2575	H	178-183	183	X	X	X	X	X	X	X
02N 02W 12ADCD1	433129116305301	43.52472	-116.5147	2570	H	-	76			X	X	X	X	X
02N 02W 20CBB1	432942116364101	43.495	-116.6114	2563	P/H	155-177	177	X	X	X	X	X	X	X
02N 02W 22CCA1	432928116340601	43.49111	-116.5683	2640	H	205-207	208	X	X	X	X	X	X	X
02N 02W 28DDD1	432826116342001	43.47389	-116.5722	2610	H	99-135	135	X	X					
02N 02W 29BCC1	432852116363601	43.48111	-116.61	2621	I	176-255	255	X	X	X	X	X	X	X
02N 02W 31CBA1	432801116374401	43.46695	-116.6289	2705	I	697-920	920	X	X	X	X	X	X	X
02N 02W	432743116362101	43.46194	-116.6058	2700	H	225-240	240	X	X	X	X	X	X	X

Well Name	Site ID	Well Latitude	Well Longitude	Surface Elevation	Use	Open Interval	Well Depth	1996 Spring	1996 Fall	1998 Spring	1998 Fall	Spring	2000 Fall	2001 Fall
32CDB1														
02N 03E 02CDD1	433157116035201	43.5325	-116.0644	3180	H	78-470	470	X	X					
02N 03E 06AAB1	433246116081701	43.54389	-116.1339	2960	I	475-1001	1001	X	X					
02N 03E 06BCC2	433221116090702	43.53917	-116.1519	3015	H/P	335-460	460	X	X	X	X	X	X	X
02N 03E 06DCA1	433202116082001	43.53389	-116.1389	3065	U	609-845	855	X	X	X	X	X	X	X
02N 03E 07BAC1	IDWR-S2000-03	43.52806	-116.1461	3064	O	553-580	580			X	X	X	X	X
02N 03E 07CDA1	433112116084501	43.52	-116.1458	3058	U/H	-	549			X	X	X	X	X
02N 03E 07DBB1	433137116084301	43.52333	-116.1431	3059	Z	551-561	561			X	X	X	X	X
02N 03E 07DBB2	433137116084601	43.52306	-116.1497	3059	Z	801-811	811			X	X	X	X	X
02N 03E 09BAA2	433150116061802	43.53056	-116.105	3140	U/H	499-522	522			X	X	X	X	X
02N 03E 09BCA2	433139116063402	43.5275	-116.1094	3135	H	599-620	620				X	X	X	X
02N 03E 11ACC1	433132116034701	43.52555	-116.0631	2838	P/R	40-100	100	X	X	X	X	X	X	X
02N 03E 18BAC1	433050116085001	43.51389	-116.1472	3070	H	605-635	642	X	X	X	X			
02N 03W 06DBA1	433217116441301	43.53806	-116.7369	2600	H	239-247	247	X	X	X	X	X	X	X
02N 03W 13BCB1	433044116390601	43.51222	-116.6517	2445	I	211-310	310			X	X	X	X	X
02N 03W 22DDC1	432919116403701	43.48861	-116.6769	2750	I	400-603	603	X	X	X	X	X	X	X
02N 03W 36DAD1	432753116375701	43.46472	-116.6325	2785	H	364-523	523	X	X					
02N 04E 29ADB1	432900115595301	43.48333	-115.9981	3680	H	20-217	227	X	X					
02N 04E 34BCB1	432805115582301	43.46806	-115.9731	3700	I	135-260	260	X	X					X
02N 04W 13ACD1	433035116452401	0	0	2315	H	97-205	205			X	X	X	X	
02N 04W 25CAD1	432840116460101	43.47778	-116.7669	2260	H	99-121	121			X		X	X	
02S 01E 23ADD1	431402116173701	43.23389	-116.2936	3155	U/I	615-816	816					X	X	X
03N 01E 01DAA1	IDWR-S2000-04	43.62666	-116.2744	2690	U/I	40-417	420	X	X	X	X	X	X	X

Well Name	Site ID	Well Latitude	Well Longitude	Surface Elevation	Use	Open Interval	Well Depth	1996 Spring	1996 Fall	1998 Spring	1998 Fall	Spring	2000 Fall	2001 Fall
03N 01E 01DAA2	433736116162802	43.62667	-116.2744	2690	I	265-420	420	X	X	X	X	X	X	X
03N 01E 06BBAB1	433801116232401	43.63361	-116.39	2590	H	63-64	64	X	X	X	X	X	X	X
03N 01E 06DDD1	433716116223001	43.62111	-116.375	2606	H	81-83	83	X	X	X	X	X	X	X
03N 01E 08DCDC1	433619116214001	43.60528	-116.3611	2650	H	-	67	X	X	X	X	X	X	X
03N 01E 10BDA1	433651116192501	43.61417	-116.3236	2650	H	99-100	100	X	X	X	X	X	X	X
03N 01E 12BCD1	433646116172101	43.61278	-116.2892	2690	I	77-87	87	X	X	X	X	X	X	X
03N 01E 13BDB1	433558116171701	43.59945	-116.2881	2735	H	91-97	97	X	X	X	X	X	X	X
03N 01E 14AAC2	433605116174602	43.60139	-116.2961	2726	U	-	1000	X	X			X	X	X
03N 01E 14AAC3	433605116174603	43.60139	-116.2961	2726	P	318-920	952	X		X		X		
03N 01E 15AAD1	433607116185201	43.60194	-116.3144	2709	H	146-151	154	X	X	X	X	X	X	X
03N 01E 15ADD1	433554116184901	43.59833	-116.3136	2701	P	479-565	565	X	X	X	X	X	X	X
03N 01E 15CBD1	433544116194601	43.59555	-116.3294	2680	H	85-90	90	X	X	X	X	X	X	X
03N 01E 15CDA1	433537116192501	43.59361	-116.3236	2706	P	301-335	335	X	X	X	X	X	X	X
03N 01E 16BCA1	433605116210001	43.60139	-116.35	2660	T/I	792-877	902	X			X	X	X	X
03N 01E 17ACA1	433601116213701	43.60028	-116.3603	2650	H	61-66	66		X		X			X
03N 01E 17BBB1	433613116222301	43.60361	-116.3731	2620	H	100-105	105	X	X	X	X	X	X	X
03N 01E 23DDD1	433433116173801	43.57583	-116.2939	2725	Z/U	25-443	446	X	X	X	X	X	X	X
03N 01E 24ADA1	433512116162501	43.58667	-116.2736	2750	H	-	144	X	X	X	X	X	X	X
03N 01E 25BCB1	433417116172701	43.57139	-116.2908	2751	H	103-109	117	X	X	X	X	X	X	X
03N 01E 27CDD1	433347116193101	43.56306	-116.3253	2717	H	113-118	118	X	X	X	X	X	X	X
03N 01E 28DCDD2	433341116202102	43.56139	-116.3392	2695	H	117-122	125	X	X	X	X	X	X	X
03N 01E 30DDD1	433347116222501	43.56306	-116.3736	2667	H	84-132	132	X	X	X	X	X	X	
03N 01E	433309116192401	43.5525	-116.3233	2718	P	169-403	425	X	X	X	X	X	X	X

Well Name	Site ID	Well Latitude	Well Longitude	Surface Elevation	Use	Open Interval	Well Depth	1996 Spring	1996 Fall	1998 Spring	1998 Fall	Spring	2000 Fall	2001 Fall
34CAA1														
03N 01E 36DDB1	433256116163301	43.54889	-116.2758	2810	I	46-152	152	X	X	X	X	X	X	X
03N 01W 03AAAA1	433800116255901	43.63334	-116.4331	2555	H	145-155	156			X	X	X	X	X
03N 01W 03DADD1	433724116255801	43.62333	-116.4328	2560	H	70-72	72			X	X	X	X	X
03N 01W 06CBBB1	433736116304201	43.62666	-116.5117	2495	H	173-175	175			X	X	X	X	X
03N 01W 06DDDC1	433712116294001	43.62	-116.4944	2510	H	69-74	80			X	X	X	X	X
03N 01W 08BDAC1	433648116285001	43.61333	-116.4806	2520	H	140-160	160	X	X	X	X	X	X	
03N 01W 09AACB1	433701116272201	43.61694	-116.4561	2539	H	94-102	102	X	X	X	X	X	X	
03N 01W 11BDCC1	433645116253801	43.6125	-116.4272	2572	H	145-150	150	X	X	X	X	X	X	X
03N 01W 12CBBB1	433646116244101	43.61194	-116.4114	2595	I	-	36	X	X	X	X	X	X	X
03N 01W 16DDDD1	433528116271101	43.59111	-116.453	2677	H	183-190	190	X	X	X	X	X	X	X
03N 01W 18DAC1	433545116295201	43.59583	-116.4978	2635	H	237-240	240	X	X	X	X	X	X	X
03N 01W 21DBCA1	433450116274001	43.58055	-116.4611	2620	H	193-295	295			X	X	X	X	X
03N 01W 24BBDA1	433517116243101	43.58805	-116.4086	2612	H	55-60	60	X	X	X	X	X	X	X
03N 01W 25DAD1	433354116233501	43.565	-116.3931	2712	H/S	327-330	330	X	X	X	X	X	X	X
03N 01W 26DDDC1	433342116245201	43.56166	-116.4144	2700	H	202-213	213	X	X	X	X	X	X	X
03N 01W 27CDCB1	433346116264901	43.56278	-116.4469	2645	H	-	200	X	X	X	X	X	X	
03N 01W 31DDA1	433302116294101	43.55	-116.4944	2542	H	31-67	67	X	X	X	X	X	X	X
03N 02E 03BAAD2	433757116121101	43.6325	-116.2031	2712	I	72-77	78	X	X	X	X	X	X	X
03N 02E 04DAB1	433729116125701	43.62472	-116.2158	2675	I	-	50	X	X	X	X	X	X	X
03N 02E 06DDC1	433713116152101	43.62028	-116.2558	2708	P	568-850	850	X	X	X		X	X	X
03N 02E 06DDD1	433710116151501	43.61945	-116.2539	2712	C	94-98	98	X	X	X	X	X	X	X
03N 02E 06DDD2	433711116151501	43.61972	-116.2542	2712	C	124-136	137	X	X	X	X	X	X	X

Well Name	Site ID	Well Latitude	Well Longitude	Surface Elevation	Use	Open Interval	Well Depth	1996 Spring	1996 Fall	1998 Spring	1998 Fall	Spring	2000 Fall	2001 Fall
03N 02E 07DAAC1	433637116151901	43.61028	-116.2553	2715	I	456-471	471	X	X	X	X	X	X	X
03N 02E 11BABD1	433705116110601	43.61806	-116.185	2743	U	781-1220	1220	X	X	X	X	X	X	X
03N 02E 11DDD1	433619116103001	43.60528	-116.175	2718	H	-	68	X	X	X	X	X	X	X
03N 02E 13BABA1	433614116095801	43.60389	-116.1661	2730	I	-	0	X	X	X	X	X	X	X
03N 02E 14ACB2	433559116105201	43.59972	-116.1811	2710	I	35-55	55	X	X	X	X	X	X	X
03N 02E 15BDB2	433557116122201	43.59917	-116.2061	2700	H/I	78-84	84	X	X	X	X	X	X	X
03N 02E 15DDDD1	433527116113401	43.59083	-116.1928	2719	U/P	-	165	X	X	X	X			
03N 02E 17CAD2	IDWR-S2000-05	43.59444	-116.2447	2727	P	399-612	650	X			X	X	X	X
03N 02E 18DAA1	433549116151301	43.59694	-116.2536	2720	I	78-80	80	X	X	X	X	X	X	X
03N 02E 19BAA2	433522116155502	43.58944	-116.2653	2765	P	468-519	525	X		X	X	X	X	
03N 02E 20DBD1	433446116141801	43.57944	-116.2383	2793	U	-	106	X	X	X	X	X	X	
03N 02E 21BCC1	433502116135201	43.58389	-116.2311	2751	D/U	-	58	X	X	X	X	X	X	X
03N 02E 23BAA1	433517116110101	43.58805	-116.1836	2720	U	-	1200					X	X	X
03N 02E 23DDBC2	433439116103501	43.5775	-116.1764	2742	I	292-362	425	X	X					
03N 02E 25AAC1	433420116091901	43.57222	-116.1553	2758	H	63-68	70	X	X	X	X	X	X	X
03N 02E 25BDA1	IDWR-S2000-06	43.57028	-116.1631	2759	I	39-65	75					X	X	X
03N 02E 25CAA1	IDWR-S2000-07	43.56778	-116.1628	2788	P	-	416					X	X	X
03N 02E 25CACC1	433353116100001	43.56472	-116.1667	2800	U	32-42	43			X	X	X	X	
03N 02E 25CBCA1	433358116101301	43.56611	-116.1703	2755	U	-	0			X	X	X	X	X
03N 02E 25CDBA1	433351116095701	43.56417	-116.1658	2815	U	37-51	51			X	X	X	X	X
03N 02E 25CDBB1	433351116100201	43.56417	-116.1672	2813	U	35-47	47			X	X	X	X	X
03N 02E 26DBA1	IDWR-S2000-08	43.5675	-116.1778	2800	P	355-644	663					X	X	X
03N 02E	433353116115201	43.56472	-116.1978	2871	P/P	365-455	455	X	X	X	X	X	X	X

Well Name	Site ID	Well Latitude	Well Longitude	Surface Elevation	Use	Open Interval	Well Depth	1996 Spring	1996 Fall	1998 Spring	1998 Fall	Spring	2000 Fall	2001 Fall
27DBD1														
03N 02E 28BDB1	433417116133001	43.57139	-116.225	2830	N	275-280	280	X	X	X	X	X	X	
03N 02E 30CAC1	433359116160301	43.56667	-116.2681	2765	H	100-103	103	X	X	X	X	X	X	X
03N 02E 30DDB1	433350116152201	43.56389	-116.2561	2785	H	-	212			X	X	X	X	X
03N 02E 31AAC1	433332116152301	43.55889	-116.2564	2682	H	136-143	143			X	X	X	X	X
03N 02E 35BAB1	433334116110601	43.55944	-116.185	2892	P	-	944							X
03N 02E 36ABC1	433328116094201	43.55833	-116.1611	2890	P	342-642	642					X	X	X
03N 02E 36CDD1	IDWR303824	43.5475	-116.1633	2930	I	517-566	570	X	X					
03N 02W 03DAA1	433735116331101	43.62639	-116.5531	2470	H	229-234	234	X	X	X	X	X	X	X
03N 02W 04ADD1	433741116342201	43.62806	-116.5728	2460	H	310-314	319	X	X	X	X	X	X	X
03N 02W 06ACD1	433737116370701	43.62694	-116.6186	2441	I	80-87	87	X	X	X	X	X	X	X
03N 02W 06DCC1	433714116371901	43.62055	-116.6219	2430	P	380-510	550	X	X	X	X	X	X	X
03N 02W 08BCCC1	433645116364001	43.6125	-116.6111	2445	C	-	94	X	X	X	X	X	X	X
03N 02W 09DDDD1	433620116342101	43.60555	-116.5725	2470	U/N	58-289	292	X	X					
03N 02W 10ACC1	433645116334301	43.6125	-116.562	2460	I/D	84-138	138	X	X	X	X			
03N 02W 12BBB1	433708116315401	43.61889	-116.5317	2488	H	58-60	61	X	X	X	X	X	X	X
03N 02W 14DBA1	433552116321501	43.59778	-116.5375	2540	P	400-605	700	X	X	X	X	X	X	X
03N 02W 15DCDA1	433532116332901	43.59222	-116.5581	2485	I/D	114-131	131	X	X	X				
03N 02W 17ACDB1	433558116355401	43.59944	-116.5983	2460	U	123-300	300	X	X	X	X	X	X	
03N 02W 17CCB2	433537116364301	43.59361	-116.6119	2450	H	73-76	104	X	X	X	X	X	X	
03N 02W 24BAD2	433516116312701	43.58694	-116.5231	2544	H	-	71	X	X	X	X	X	X	X
03N 02W 26BAA1	433433116323001	43.57583	-116.5417	2505	H	34-83	83	X	X	X	X	X	X	X
03N 02W 29BCD1	433410116362601	43.56944	-116.6072	2467	H	-	116	X	X	X	X	X	X	X

Well Name	Site ID	Well Latitude	Well Longitude	Surface Elevation	Use	Open Interval	Well Depth	Spring	1996 Fall	1998 Spring	1998 Fall	2000 Spring	2000 Fall	2001 Fall
03N 02W 31BCC1	433317116375401	43.55416	-116.6314	2590	I	152-172	172	X	X	X	X	X	X	X
03N 02W 34BBCB1	433335116341501	43.55972	-116.5708	2490	I	165-200	210	X	X	X	X	X	X	X
03N 02W 35DBAC1	433311116321901	43.55305	-116.5386	2503	I/H	67-117	117	X	X	X	X	X	X	X
03N 03E 07CBAC1	433636116090201	43.61	-116.1506	3160	U	129-290	290	X	X					
03N 03E 19DBD1	433449116082001	43.58028	-116.1389	2800	H	75-80	80	X	X	X	X	X	X	X
03N 03E 29ADD2	433408116065202	43.56889	-116.1144	2810	P	81-101	106	X	X	X	X	X	X	X
03N 03E 29CCDA2	433343116074301	43.56194	-116.1286	2820	H	140-100	100			X	X	X	X	X
03N 03E 30BCBD1	433413116090401	43.57028	-116.1508	2762	H	-	48	X	X	X	X	X	X	X
03N 03E 30DAAD2	433406116080101	43.56694	-116.1333	2750	P/I	-	60	X	X	X	X	X	X	X
03N 03E 30DDAA1	433351116380301	43.56417	-116.1342	2800	U	246-940	940	X	X	X	X	X	X	X
03N 03E 31BDD1	IDWR-S2000-09	43.55361	-116.1444	2945	P	527-818	838					X	X	X
03N 03E 31CAA1	433313116083901	43.55416	-116.1444	2945	P	-	0					X	X	
03N 03E 32BBA1	433337116075001	43.56028	-116.1306	2823	U/C	232-260	280	X	X	X	X	X	X	X
03N 03E 32CDD1	433247116072601	43.54639	-116.1239	2965	Z/Z	560-731	802	X	X	X	X	X	X	X
03N 03E 33DAA1	433310116054201	43.55278	-116.095	2862	H	120-127	127	X	X	X	X	X	X	X
03N 03W 03BCB2	433745116412501	43.62917	-116.6903	2429	U	22-94	95		X	X	X	X	X	X
03N 03W 06DDC1	433710116441101	43.61944	-116.7361	2560	I	131-137	255	X	X	X	X	X	X	X
03N 03W 09BAB1	433704116421901	43.61777	-116.7053	2500	H	98-122	122		X	X	X	X	X	X
03N 03W 10CBA3	433636116411901	43.61	-116.6886	2560	T/I	70-300	300	X	X					
03N 03W 11DAC1	433630116392401	43.60833	-116.6567	2441	I/D	-	90	X	X	X	X			
03N 03W 14CDA1	433531116394601	43.59194	-116.6628	2480	H	69-79	80	X	X					
03N 03W 23BBC1	433517116401801	43.58805	-116.6717	2540	U/I	118-190	250	X	X	X	X	X	X	X
03N 03W	433433116392701	43.57583	-116.6575	2490	I	50-80	97	X	X	X	X	X	X	X

Well Name	Site ID	Well Latitude	Well Longitude	Surface Elevation	Use	Open Interval	Well Depth	Spring	1996 Fall	1998 Spring	1998 Fall	2000 Spring	2000 Fall	2001 Fall
23DCD1														
03N 03W 27ABB1	433427116405001	43.57417	-116.6805	2450	I	119-122	122	X	X	X	X	X	X	X
03N 03W 31ADA1	433321116435601	43.55583	-116.7322	2630	H	159-260	260			X	X	X	X	
03N 04W 03AAD1	433746116473101	43.62944	-116.7919	2487	P	70-75	78	X	X	X	X	X	X	
03N 04W 05AAB1	433755116500901	43.63194	-116.8358	2618	I	140-325	325	X	X					
03N 04W 07ABA1	433703116513001	43.6175	-116.8583	2462	I	208-503	503			X	X	X	X	X
03N 04W 11ADA1	433646116461801	43.61278	-116.7717	2497	U	94-175	175	X	X	X	X	X	X	X
03N 04W 12AAD2	433655116451001	43.61528	-116.7528	2492	H	233-270	270			X	X	X	X	X
03N 04W 13BBC1	433601116461001	43.60028	-116.7694	2535	H	205-295	295	X	X	X	X	X		
03N 04W 15DCC1	433517116475501	43.58805	-116.7986	2378	H	79-80	80	X	X	X	X	X	X	X
03N 05W 03ADA1	433740116544201	43.62778	-116.9117	2285	C	40-55	55			X	X	X	X	
03N 05W 03DBD1	433723116550201	43.62305	-116.9172	2250	P	456-533	533			X	X	X	X	X
03N 05W 11DAD1	433627116532701	43.6075	-116.8908	2280	H/S	85-86	86			X	X	X	X	X
04N 01E 03DAD1	434243116185001	43.71194	-116.3139	2700	U	100-140	250	X	X	X	X	X	X	X
04N 01E 04BCCD1	434250116210401	43.71389	-116.3511	2600	H	387-465	470	X	X	X	X	X	X	X
04N 01E 04DCC1	IDWR347115	43.70694	-116.3428	2632	U	276-285	285	X	X	X	X			
04N 01E 05CBBD1	434245116221701	43.7125	-116.3714	2590	H	-	30	X	X	X	X	X	X	X
04N 01E 10ACB2	434206116192001	43.70167	-116.3222	2636	H	289-308	308	X	X		X	X	X	X
04N 01E 11BAA1	434216116183501	43.705	-116.3039	2800	H	290-300	335	X	X	X	X	X	X	X
04N 01E 11BBB1	434223116183901	43.70639	-116.3108	2690	H	120-203	203	X	X	X	X	X	X	X
04N 01E 13BDD1	434109116170701	43.68583	-116.2853	2620	H	70-78	78					X	X	X
04N 01E 14CCB1	434048116184401	43.68	-116.3122	2582	U	300-340	357					X	X	X
04N 01E 14CCB2	434048116184402	43.68	-116.3122	2582	U	270-290	295					X	X	X

Well Name	Site ID	Well Latitude	Well Longitude	Surface Elevation	Use	Open Interval	Well Depth	Spring	1996 Fall	1998 Spring	1998 Fall	2000 Spring	2000 Fall	2001 Fall
04N 01E 14CCB3	434048116184403	43.68	-116.3122	2582	U	210-250	250					X	X	X
04N 01E 14CCB4	434048116184404	43.68	-116.3122	2582	U	130-170	177					X	X	X
04N 01E 15BADC1	434121116192901	43.68917	-116.3247	2575	P	1-18	103						X	X
04N 01E 16AAA1	434129116200301	43.69139	-116.3342	2565	H/S	87-88	88	X	X	X	X	X	X	
04N 01E 17CDD1	434042116215001	43.67833	-116.3639	2546	H	-	115	X	X	X	X	X	X	X
04N 01E 21DCCC1	433948116203401	43.66333	-116.3428	2605	H	99-104	106	X	X	X	X	X	X	X
04N 01E 21DDDC1	433950116200401	43.66389	-116.3344	2630	U	93-102	102	X	X	X	X	X	X	X
04N 01E 23DAC1	433957116173601	43.66833	-116.2961	2698	P	327-403	403	X	X	X	X			
04N 01E 24BCA1	434020116171901	43.67222	-116.2886	2602	H	50-70	71	X	X	X	X			
04N 01E 26CDD1	433856116181501	43.64889	-116.3042	2660	H	96-105	105	X	X	X	X	X	X	X
04N 01E 27AADA1	433939116184801	43.66084	-116.3133	2613	U/U	620-868	892	X	X	X	X	X	X	X
04N 01E 29CCCD1	433856116221601	43.64889	-116.3711	2605	H	84-89	90	X	X	X	X	X	X	X
04N 01E 33AADC1	433843116200701	43.64528	-116.3353	2637	H	96-101	103	X	X	X	X	X	X	X
04N 01E 34ACB1	433838116192301	43.64389	-116.3231	2643	H	145-150	160							X
04N 01E 34ACBC1	433837116192301	43.64361	-116.3231	2644	H	476-481	481		X	X	X	X	X	X
04N 01E 34CAD1	433819116192501	43.6375	-116.3247	2650	P	671-752	755	X	X					
04N 01E 35CCA1	433813116183201	43.63695	-116.3089	2660	D/I	90-108	109	X	X	X	X	X	X	X
04N 01E 35DAA1	433822116174101	43.63945	-116.2947	2675	H	175-205	205	X	X	X	X	X	X	X
04N 01E 36BAC1	433843116171601	43.645	-116.2875	2673	U	760-1005	1005	X	X	X	X			
04N 01E 36BAC2	433842116171601	43.645	-116.2875	2673	P	474-545	551	X		X		X	X	X
04N 01W 01CAA1	434244116241101	43.71222	-116.4031	2552	H	239-260	260	X	X	X	X	X	X	X
04N 01W 03CDDA1	434228116263401	43.70778	-116.4428	2502	H	51-57	57	X	X	X	X	X	X	X
04N 01W	434243116284501	43.71194	-116.4792	2520	H	132-142	142	X	X	X	X	X	X	

Well Name	Site ID	Well Latitude	Well Longitude	Surface Elevation	Use	Open Interval	Well Depth	Spring	1996 Fall	1998 Spring	1998 Fall	2000 Spring	2000 Fall	2001 Fall
05DBD1														
04N 01W 07AAD1	434219116293401	43.70528	-116.4928	2465	H	162-172	172	X	X	X	X	X	X	X
04N 01W 07DAAA1	434156116293301	43.69889	-116.4925	2465	U/P	420-440	440	X	X	X	X	X	X	X
04N 01W 13AACC1	434106116240301	43.68861	-116.3972	2525	I	240-320	332	X	X	X	X	X	X	X
04N 01W 13DDB1	434048116235101	43.68	-116.3975	2525	I	-	130	X	X	X	X	X		
04N 01W 16CAA1	434104116274701	43.68444	-116.4631	2482	H	150-152	160	X	X					
04N 01W 17BBDB1	434124116292101	43.69	-116.4892	2470	H	140-149	149		X	X	X	X	X	X
04N 01W 17BBDC1	434120116292101	43.68889	-116.4892	2468	H	381-424	424	X	X	X	X	X	X	X
04N 01W 17CBDB1	434059116292101	43.68306	-116.4892	2465	H	113-118	118	X						
04N 01W 19DADA1	434007116293501	43.66861	-116.4931	2495	H	161-170	170	X	X	X	X	X	X	
04N 01W 22DBB1	434013116262801	43.67028	-116.4411	2545	H	80-93	93	X	X	X	X	X	X	
04N 01W 23ACCC2	434013116252201	43.67028	-116.4228	2560	H	150-155	155			X	X	X	X	X
04N 01W 24ACAB1	434026116235601	43.67389	-116.3989	2570	H	109-120	120			X	X	X	X	X
04N 01W 24ACAB3	434025116235901	43.67361	-116.3997	2570	Q	300-313	313			X	X	X	X	
04N 01W 24BCAC1	434020116243401	43.67222	-116.4094	2575	H	230-235	235			X	X	X	X	X
04N 01W 28ADD1	433923116271001	43.65639	-116.4528	2535	H	72-80	80	X	X	X	X	X	X	X
04N 01W 30ABBC1	433942116300901	43.66167	-116.5025	2500	H	230-237	237			X	X	X	X	X
04N 01W 30ADAA2	433934116293602	43.65917	-116.493	2505	H	89-99	99	X	X		X	X	X	X
04N 01W 31AAA1	433852116293401	43.64778	-116.4928	2508	I	455-462	462	X	X	X	X	X	X	X
04N 01W 32BBBC1	433849116293201	43.64695	-116.4922	2510	H	60-65	65	X	X	X	X	X	X	X
04N 01W 33ADAD1	433835116271201	43.64306	-116.4533	2530	H	67-77	77	X	X	X	X	X	X	X
04N 01W 33CBB1	433828116281701	43.64111	-116.4714	2525	H	-	400	X	X					
04N 01W 35AAA1	433852116244801	43.64778	-116.4133	2571	H/U	-	44	X	X	X	X	X	X	X

Well Name	Site ID	Well Latitude	Well Longitude	Surface Elevation	Use	Open Interval	Well Depth	Spring	1996 Fall	1998 Spring	1998 Fall	2000 Spring	2000 Fall	2001 Fall
04N 02E 09CCD2	434131116134201	43.69194	-116.2283	3200	H	-	0							X
04N 02E 17CABC1	434103116143601	43.68278	-116.2467	3020	H	110-525	525					X	X	X
04N 02E 19ABB1	434035116154401	43.67639	-116.2622	2680	H	-	98	X	X	X	X	X	X	X
04N 02E 21DACA1	434003116125701	43.6675	-116.2158	2890	A	644-880	880	X	X					
04N 02E 25DCBB1	433901116093901	43.65139	-116.1614	3490	H	339-340	340	X	X					
04N 02E 29ACA1	433930116141901	43.65833	-116.2386	2670	H	43-48	85							X
04N 02E 29ACC1	433921116143401	43.65583	-116.2428	2663	I	-	45	X	X	X	X	X	X	X
04N 02E 29ACDB1	433925116141901	43.65694	-116.2386	2670	I/A	-	1195	X	X	X	X	X	X	X
04N 02E 30ACAC1	433929116153701	43.65778	-116.2594	2630	I	-	0	X	X					
04N 02E 30ACDB1	433928116153801	43.6575	-116.2597	2630	H	-	41	X	X	X	X	X	X	X
04N 02E 31AAB2	433850116151701	43.64722	-116.2547	2630	H	-	60	X	X	X	X	X	X	X
04N 02E 31ACAB1	433838116153601	43.64389	-116.26	2632	U	-	0	X	X					
04N 02E 33ACAC1	433836116132701	43.64333	-116.2194	2695	I/H	47-52	53	X	X	X	X	X	X	X
04N 02E 34CAAC1	433821116121701	43.63917	-116.2047	2728	H/I	69-100	100	X	X	X	X	X	X	X
04N 02E 35CBBA1	433824116112501	43.63972	-116.1894	2850	U	737-771	781	X	X					
04N 02W 01AADA1	434310116304501	43.71944	-116.5125	2480	H	-	0			X	X	X	X	X
04N 02W 01ADAA3	434301116304401	43.71695	-116.5122	2480	H	74-84	84			X	X	X	X	X
04N 02W 01DCDD1	434225116310301	43.70694	-116.5175	2450	H	530-675	675			X	X	X	X	X
04N 02W 02DDD1	434226116315701	43.70722	-116.5325	2445	H	31-50	50	X	X	X	X	X	X	X
04N 02W 05ABB1	434314116360401	43.72055	-116.6011	2497	P	-	475	X	X					
04N 02W 06CDD1	434228116372701	43.70778	-116.6242	2404	P	404-420	420	X	X	X	X	X	X	X
04N 02W 07AAC1	434214116365901	43.70389	-116.6164	2395	H	40-42	42	X	X	X	X	X	X	X
04N 02W	434200116353201	43.7	-116.5922	2407	H	60-80	80		X	X	X	X	X	X

Well Name	Site ID	Well Latitude	Well Longitude	Surface Elevation	Use	Open Interval	Well Depth	Spring	1996 Fall	1998 Spring	1998 Fall	2000 Spring	2000 Fall	2001 Fall
08ADD1														
04N 02W 10BBCB1	434217116341801	43.70472	-116.5717	2420	H	128-133	133	X	X	X	X	X	X	X
04N 02W 21CBB1	434014116353201	43.67056	-116.5922	2432	H	79-90	90	X	X	X	X	X	X	X
04N 02W 22DCD1	433948116333201	43.66333	-116.5589	2458	H	237-262	262			X	X	X	X	
04N 02W 24CCC1	433951116315401	43.66417	-116.5317	2479	I	53-77	77	X	X	X	X	X	X	X
04N 02W 26CAD1	433910116323301	43.65278	-116.5425	2472	I	140-152	152	X	X	X	X			
04N 02W 31AAA1	433852116364501	43.64778	-116.6125	2438	H	-	150	X	X	X	X	X	X	X
04N 02W 33ABC1	433844116345401	43.64556	-116.5817	2455	I	123-148	148	X	X	X	X			
04N 02W 36CCC1	433757116320101	43.63472	-116.5317	2480	H	106-108	108			X	X	X	X	X
04N 03W 01CBBA1	434248116385901	43.71333	-116.6497	2420	H	213-218	218			X	X	X	X	X
04N 03W 02ADDD1	434249116390901	43.71361	-116.6525	2430	H	97-135	135			X	X	X	X	X
04N 03W 04DCB1	434233116420201	43.70917	-116.7006	2430	H/I	259-293	296	X	X	X	X	X	X	X
04N 03W 04DDCD1	434224116414401	43.70667	-116.6956	2465	H	199-227	227	X	X	X	X	X	X	X
04N 03W 06AAA1	434312116435501	43.72	-116.7319	2372	I	31-160	160	X	X	X	X	X	X	X
04N 03W 12ACDD1	434200116381701	43.7	-116.6381	2387	U/I	10-35	40	X	X	X	X	X	X	X
04N 03W 13BAA1	434128116383601	43.69111	-116.6433	2370	S	181-185	185	X	X	X	X	X	X	X
04N 03W 15ADC1	434105116402701	43.68472	-116.6742	2440	U	875-1010	1010					X	X	X
04N 03W 15ADC2	434105116402702	43.68472	-116.6742	2440	U	579-725	725					X	X	X
04N 03W 15ADC3	434105116402703	43.68472	-116.6742	2440	U	430-550	550					X	X	X
04N 03W 15ADC4	434105116402704	43.68472	-116.6742	2440	U	270-407	407					X	X	X
04N 03W 15ADC5	434105116402705	43.68472	-116.6742	2440	U	208-270	270					X	X	X
04N 03W 15ADC6	434105116402706	43.68472	-116.6742	2440	U	166-208	208					X	X	X
04N 03W 15ADC7	434105116402707	43.68472	-116.6742	2440	U	122-166	166					X	X	X

Well Name	Site ID	Well Latitude	Well Longitude	Elevation	Use	Open Interval	Well Depth	1996 Spring	1996 Fall	1998 Spring	1998 Fall	2000 Spring	2000 Fall	2001 Fall
04N 03W 15ADC8	434105116402708	43.68472	-116.6742	2440	U	110-120	122					X	X	X
04N 03W 16DDDC1	434038116413801	43.67722	-116.6939	2348	U/I	57-75	80	X	X	X	X	X	X	X
04N 03W 24ACB1	434024116382901	43.67334	-116.6414	2412	H	-	92	X	X	X	X	X	X	X
04N 03W 25DAA3	433919116375701	43.65528	-116.6325	2424	U	62-68	80	X	X	X	X			
04N 03W 26ABCC1	433935116394301	43.65973	-116.6619	2412	P	286-503	515	X	X					
04N 03W 27AACD1	433934116403201	43.65945	-116.6756	2380	P	175-320	330	X	X	X	X	X	X	X
04N 03W 27CBAD1	433915116411701	43.65417	-116.6881	2380	I	76-97	97	X	X	X	X	X	X	X
04N 03W 28ADD1	433921116413501	43.65583	-116.6931	2378	P	150-200	395	X	X	X	X	X	X	X
04N 03W 30ADA1	433935116441001	43.65806	-116.7322	2353	H	160-192	192	X	X	X	X	X	X	X
04N 03W 31CBA2	433825116445702	43.64028	-116.7492	2467	H	-	0			X	X	X	X	X
04N 03W 33DADC1	433815116413801	43.6375	-116.6939	2440	H	348-357	357			X	X	X	X	X
04N 04W 04CDC1	434225116493101	43.70694	-116.8253	2285	H/S	387-420	420	X	X	X	X	X	X	X
04N 04W 05CAC1	434234116504601	43.70945	-116.8461	2280	H	168-224	224		X	X	X	X	X	X
04N 04W 08BB1	IDWR297941	43.70383	-116.8492	2280	H	210-230	230	X						
04N 04W 08CDCC1	434128116504401	43.69111	-116.8456	2350	H	58-70	70			X	X	X	X	X
04N 04W 10CDAB1	434138116481201	43.69389	-116.8033	2300	H/S	97-116	116			X	X	X	X	X
04N 04W 15ACCB2	434108116480402	43.68555	-116.8011	2304	H	68-74	74			X	X	X	X	
04N 04W 15ACCB3	434107116480501	43.68528	-116.8014	2304	H	215-220	220	X		X		X	X	X
04N 04W 21CAA1	434008116492001	43.66889	-116.8222	2440	H	35-36	36	X	X	X		X	X	X
04N 04W 21CAA2	432835116492501	43.66945	-116.8225	2420	H	35-36	36	X	X	X		X	X	
04N 04W 22DDD1	433945116473201	43.6625	-116.7922	2353	I	72-132	137	X	X	X				
04N 04W 25BDD3	433919116454903	43.65528	-116.7636	2368	I/U	138-175	175	X	X	X	X			
04N 04W	433929116491501	43.65806	-116.8208	2470	H/S	54-56	56	X	X	X	X	X	X	X

Well Name	Site ID	Well Latitude	Well Longitude	Surface Elevation	Use	Open Interval	Well Depth	Spring	1996 Fall	1998 Spring	1998 Fall	2000 Spring	2000 Fall	2001 Fall
28ACB1														
04N 04W 30BBB1	433942116520101	43.66167	-116.8669	2461	U/H	76-85	85	X		X	X	X	X	X
04N 04W 30BBB2	433941116521301	43.66139	-116.8703	2480	H	34-71	71	X	X	X	X	X	X	X
04N 04W 33CDC2	433800116493001	43.63334	-116.825	2525	U/I	50-63	72	X	X	X	X	X	X	X
04N 04W 36DB1	IDWR297845-X	43.63867	-116.7695	2494	H	564-586	586	X						
04N 05W 07DCD1	434132116584001	43.69222	-116.9778	2292	I	64-131	131	X	X	X	X	X	X	X
04N 05W 10CDD1	434128116551601	43.69111	-116.9211	2423	H/S	287-306	306	X	X	X	X	X	X	X
04N 05W 14CCC2	434040116543502	43.67778	-116.9097	2424	P	500-910	910	X	X	X				
04N 05W 14DAD1	434053116532901	43.68139	-116.8914	2421	H	56-65	65	X	X	X	X	X	X	X
04N 05W 21AAB2	434033116560501	43.67583	-116.9347	2440	H	178-220	220	X	X	X	X	X	X	X
04N 05W 23BCC1	434009116543701	43.66917	-116.9103	2465	P	285-515	525	X	X					
04N 05W 23CBB1	434006116543701	43.66833	-116.9103	2467	H	68-80	80			X	X	X	X	
04N 06W 02DDA1	434234117004501	43.70945	-117.0125	2420	H	123-280	280			X	X	X	X	X
04N 06W 11DCA1	434138117010101	43.69389	-117.0169	2240	H/S	30-31	31			X	X	X	X	X
04N 06W 12CAC1	434141117002001	43.69473	-117.0056	2275	H	83-123	123			X	X	X	X	X
05N 01E 26CDDC1	434409116182101	43.73583	-116.3058	2715	H	-	61	X	X	X	X	X	X	X
05N 01E 26DCD1	434412116175801	43.73972	-116.2992	2750	H/I	633-688	688	X	X	X	X	X	X	X
05N 01E 29DCA1	434415116213401	43.7375	-116.3594	2740	H/S	244-246	247	X	X	X	X	X	X	X
05N 01E 31ACA1	434349116224101	43.73028	-116.3781	2655	H	90-99	99	X	X	X	X	X	X	
05N 01E 33CCCD1	434316116210501	43.72111	-116.3514	2632	H	168-190	190	X	X	X	X	X	X	X
05N 01E 34DBB1	434341116192001	43.72805	-116.3222	2680	I	-	175	X	X	X	X	X	X	X
05N 01E 35ACA1	434350116175701	43.73056	-116.2992	2720	S	-	0	X	X	X	X	X	X	X
05N 01E 36AAB1	434404116164001	43.73444	-116.2778	2780	I	144-230	230	X	X	X	X	X	X	X

Well Name	Site ID	Well Latitude	Well Longitude	Elevation	Use	Open Interval	Well Depth	1996 Spring	1996 Fall	1998 Spring	1998 Fall	2000 Spring	2000 Fall	2001 Fall
05N 01W 09CAD1	434700116274501	43.78333	-116.4625	2688	H/I	390-450	450			X	X	X	X	X
05N 01W 09CCD2	434650116280802	43.78056	-116.4689	2680	I	285-415	425	X	X		X	X	X	X
05N 01W 16CAB1	434615116275801	43.77083	-116.4656	2715	H	492-628	628			X	X	X	X	
05N 01W 17BCA1	434628116292101	43.77444	-116.4892	2630	H/I	222-237	237	X	X	X	X	X	X	
05N 01W 29CBA1	434433116291601	43.74167	-116.4889	2630	I	272-332	332	X	X	X	X	X	X	X
05N 01W 32ACC1	434344116285401	43.72889	-116.4817	2595	H	-	280	X	X	X	X	X	X	X
05N 01W 33ACD1	434344116273301	43.72889	-116.4592	2590	H	106-108	108	X	X	X	X	X	X	
05N 01W 33CBDA1	434336116280301	43.72667	-116.4675	2560	H	185-188	188			X	X	X	X	X
05N 01W 34DBAD1	434335116261501	43.72639	-116.4375	2585	H	-	74	X	X	X	X	X	X	X
05N 01W 35CCC1	434321116255301	43.7225	-116.4314	2582	I	44-84	84	X	X	X	X	X	X	X
05N 01W 36ABB1	434406116240801	43.735	-116.4022	2618	H/I	204-208	208	X	X	X	X	X	X	X
05N 02E 29BCC1	434433116150401	43.7425	-116.2511	2990	H	14-68	68	X	X					
05N 02E 31CAB1	434341116160201	43.72806	-116.2672	2815	I	48-254	254	X	X					
05N 02W 19CBA1	434525116373601	43.75694	-116.6267	2482	U	254-260	261	X	X	X	X	X	X	X
05N 02W 19CBA2	434525116373602	43.75694	-116.6267	2482	H	-	0		X	X	X	X	X	X
05N 02W 20BBA1	434551116362801	43.76417	-116.6078	2500	S	71-114	117	X	X	X	X	X	X	X
05N 02W 22CAD1	434514116334501	43.75389	-116.5625	2605	I	279-403	450	X	X	X	X	X	X	X
05N 02W 24DAB1	434525116305101	43.75694	-116.5142	2595	S	280-320	330	X	X	X	X	X	X	
05N 02W 25BCD1	434436116313601	43.74333	-116.5267	2632	I	-	448	X	X					
05N 02W 27DCC1	434413116334201	43.73695	-116.5617	2565	H	213-218	218	X	X	X	X	X	X	X
05N 02W 29BBC2	434452116364101	43.74778	-116.6114	2505	H	164-180	180	X	X	X	X	X	X	X
05N 02W 31BBC1	434356116375201	43.73222	-116.6311	2472	H	102-132	133	X	X	X	X	X	X	
05N 02W	434331116362501	43.72528	-116.6069	2500	H	230-233	233	X	X	X	X	X	X	

Well Name	Site ID	Well Latitude	Well Longitude	Elevation	Use	Open Interval	Well Depth	1996 Spring	1996 Fall	1998 Spring	1998 Fall	2000 Spring	2000 Fall	2001 Fall
32CBD1														
05N 03W 02CCD1	434738116400501	43.79389	-116.6681	2560	H	380-384	386	X	X	X	X	X	X	X
05N 03W 04BCB1	434815116423901	43.80416	-116.7108	2460	H	140-143	143	X	X	X	X	X	X	
05N 03W 08DDC1	434646116425401	43.77917	-116.7153	2450	H	197-203	203	X	X	X	X	X	X	X
05N 03W 12CCA1	434652116385201	43.78111	-116.6478	2560	H	60-314	314	X	X	X	X	X	X	X
05N 03W 15DDC1	434554116403101	43.765	-116.6753	2495	H/S	147-152	152	X	X	X	X	X	X	X
05N 03W 19AAD1	434545116435701	43.7625	-116.7325	2440	H	131-143	143	X	X	X	X	X	X	X
05N 03W 21CAD1	434517116421101	43.75472	-116.703	2480	H	177-200	200	X	X	X	X	X	X	X
05N 03W 23BC1	IDWR297637	43.75923	-116.6693	2500	H	345-352	352		X					
05N 03W 27CAA1	434432116405801	43.74222	-116.6828	2450	H	236-287	287	X	X					
05N 03W 30ADD1	434430116435601	43.74306	-116.7322	2475	H	158-180	180	X	X	X	X	X	X	X
05N 04W 08BCC1	434716116505401	43.78667	-116.8519	2430	H	196-202	202	X	X	X	X	X	X	X
05N 04W 09DCA1	434651116490501	43.78083	-116.8181	2460	H	274-279	281	X	X	X	X	X	X	X
05N 04W 16ABA1	434640116490301	43.77778	-116.8175	2430	H	261-333	333	X	X	X	X	X	X	
05N 04W 20DADD1	434510116495501	43.75278	-116.8319	2350	H	99-102	102		X	X	X	X	X	X
05N 04W 21CABB2	434522116493201	43.75611	-116.8256	2350	H	180-203	203	X		X	X	X	X	X
05N 04W 24ABA1	434543116453301	43.76194	-116.7592	2510	I	264-415	448	X	X	X	X	X	X	X
05N 04W 34BCB1	434346116484101	43.72945	-116.8114	2300	H/S	115-190	190	X	X	X	X	X	X	X
05N 04W 35BBB1	434359116472801	43.73306	-116.7911	2330	H	74-75	75	X	X	X	X	X	X	X
05N 04W 36BCC1	434339116461201	43.7275	-116.77	2345	I	135-146	146	X	X	X	X	X	X	X
05N 05W 04BCC1	434759116570201	43.79972	-116.9506	2285	S/I	45-46	46	X	X	X	X	X	X	X
05N 05W 04DCD1	434733116561501	43.7925	-116.9375	2281	P	245-477	505	X	X	X	X	X	X	X
05N 05W 09BDB1	434714116564201	43.7875	-116.9444	2225	U/P	245-440	450			X	X	X	X	X

Well Name	Site ID	Well Latitude	Well Longitude	Elevation	Use	Open Interval	Well Depth	1996 Spring	1996 Fall	1998 Spring	1998 Fall	2000 Spring	2000 Fall	2001 Fall
05N 05W 10BBCB1	434724116555001	43.79	-116.9305	2275	H	100-122	123			X	X	X	X	X
05N 05W 13CBC1	434605116532601	43.76805	-116.8906	2311	U/I	39-142	142	X	X	X	X	X	X	X
05N 05W 18CAC1	434603116590901	43.7675	-116.9858	2225	H	-	250	X	X	X	X	X	X	X
05N 05W 20CCD1	434459116575001	43.74972	-116.9639	2255	H	36-37	37	X	X	X	X	X	X	X
05N 05W 27DDBC1	434411116545301	43.73639	-116.9147	2260	H	60-61	61			X	X	X	X	X
05N 05W 29CDDA1	434409116574101	43.73583	-116.9614	2375	H	199-222	222			X	X	X	X	X
05N 05W 32AAAA1	434402116570501	43.73389	-116.9514	2378	I	210-380	385			X	X	X	X	X
05N 05W 32CDC1	434313116574901	43.72028	-116.9636	2312	H/S	57-58	58	X	X	X	X	X	X	X
05N 05W 33ACCC1	434349116562401	43.7275	-116.9408	2380	I	198-348	368			X	X	X	X	
05N 06W 01CDD1	434735117000801	43.79306	-117.0022	2200	S	40-47	47			X	X	X	X	X
05N 06W 11AAD1	434725117004101	43.79028	-117.0114	2195	H	76-82	82	X	X	X	X	X	X	X
05N 06W 26CAA1	434430117012301	43.74167	-117.0231	2210	U/H	-	34	X	X	X	X	X	X	X
05N 06W 35CAC1	434310117011201	43.725	-117.0217	2275	H	42-43	43	X	X	X	X	X	X	X
06N 03W 22CBB1	435032116412801	43.84222	-116.6911	2570	H	-	235	X	X	X	X	X	X	X
06N 03W 30DCC1	434920116442701	43.82222	-116.7408	2440	H	206-216	216	X	X	X	X	X	X	X
06N 03W 33CBA1	434845116422901	43.8125	-116.7081	2480	H	-	152	X	X	X	X	X	X	
06N 04W 28CDC1	434922116493301	43.82278	-116.8258	2630	I	369-705	705	X	X					
06N 04W 34DDB1	434835116474301	43.80972	-116.7953	2480	H	144-147	147	X	X	X	X	X	X	X
06N 04W 35ADC1	433858116463401	43.81611	-116.7761	2620	H	352-362	362	X	X	X	X	X	X	X
06N 05W 30CDC1	434920116591701	43.82222	-116.9881	2335	H	60-62	62			X	X	X	X	X
06N 05W 35BAC1	434910116542701	43.81944	-116.9075	2520	H	298-322	322	X	X	X	X	X	X	X
06N 05W 36CDB1	434836116531201	43.81	-116.8867	2500	I	308-385	385	X	X	X	X	X	X	X
SUMMARY: Number of Wells								343	343	383	372	392	390	341

Appendix E. POTENTIOMETRIC SURFACE MAPS

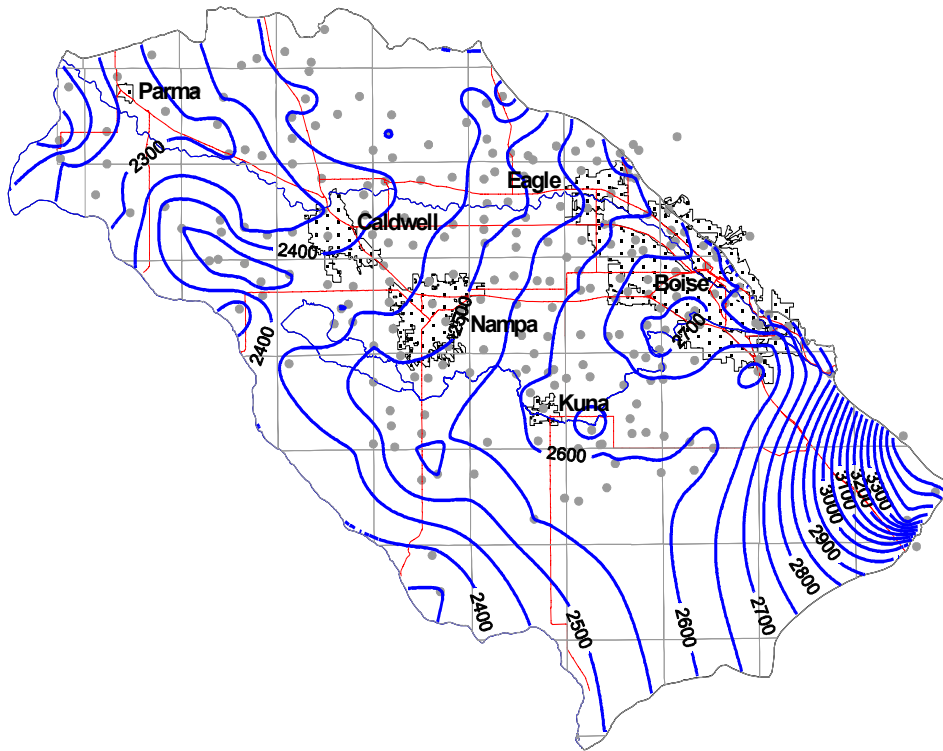

Figure E-1: Spring 1996, shallow zone (240 wells).

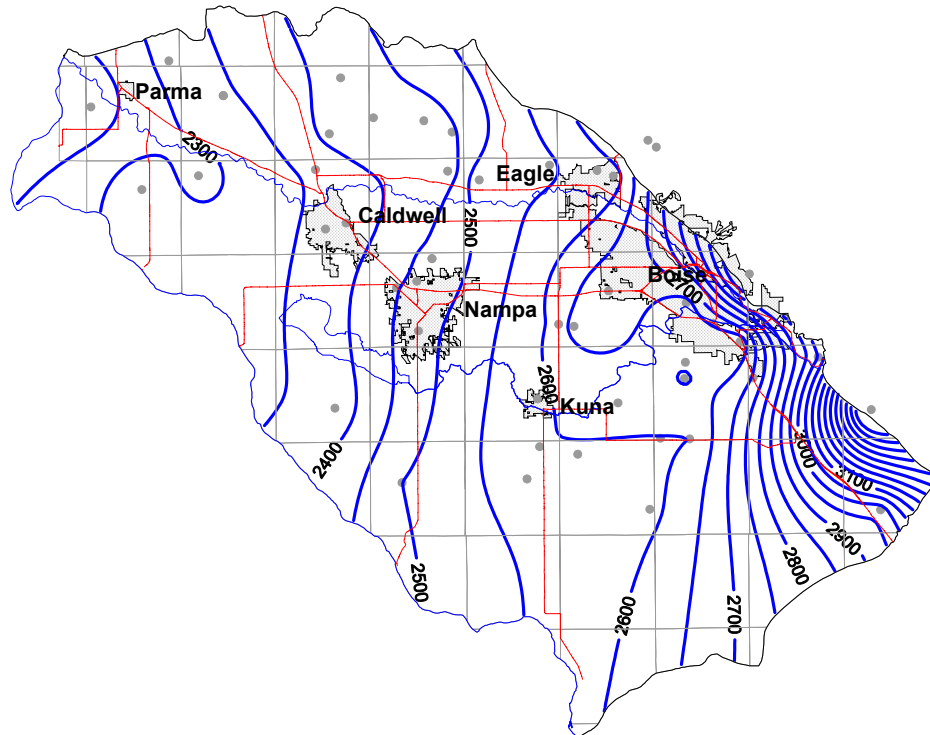

Figure E-2: Spring 1996, intermediate zone (49 wells).

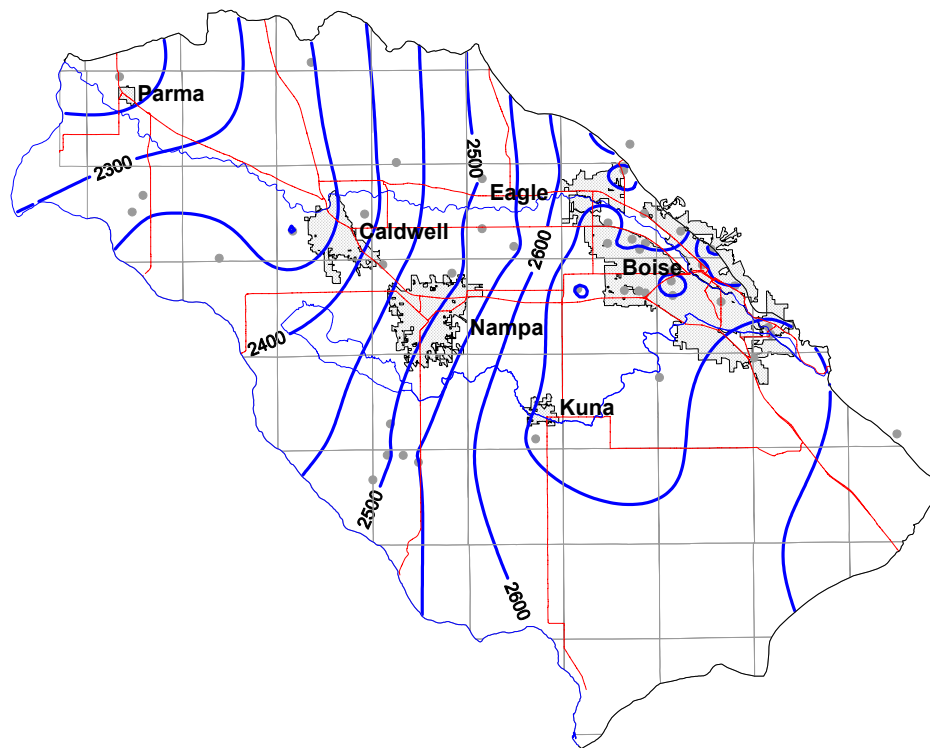

Figure E-3: Spring 1996, deep zone (45 wells).

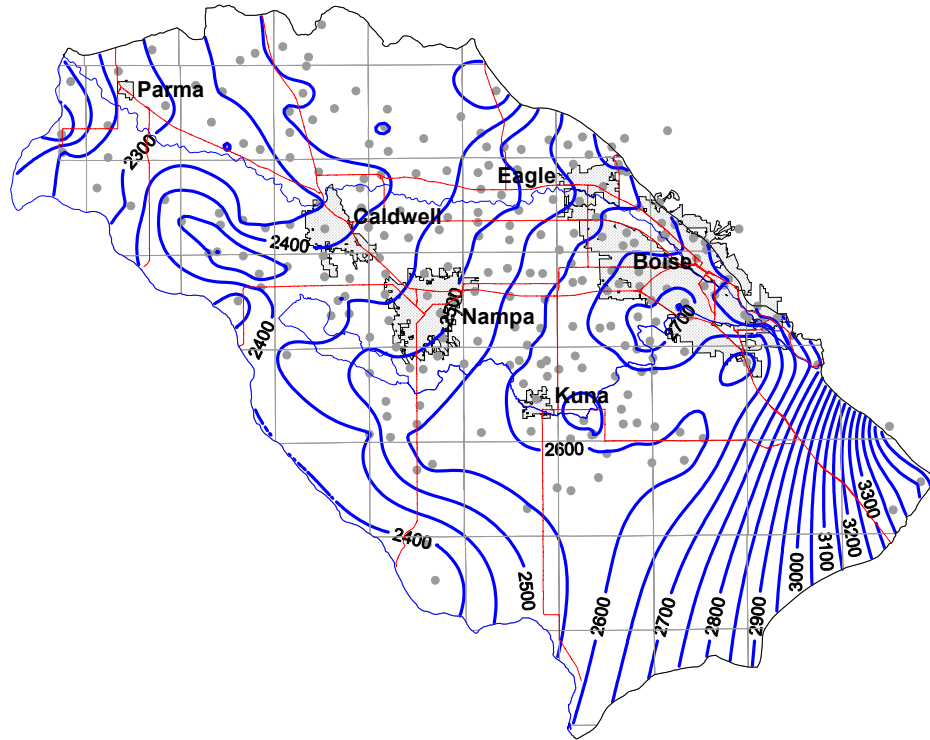

Figure E-4: Fall 1996, shallow zone (235 wells).

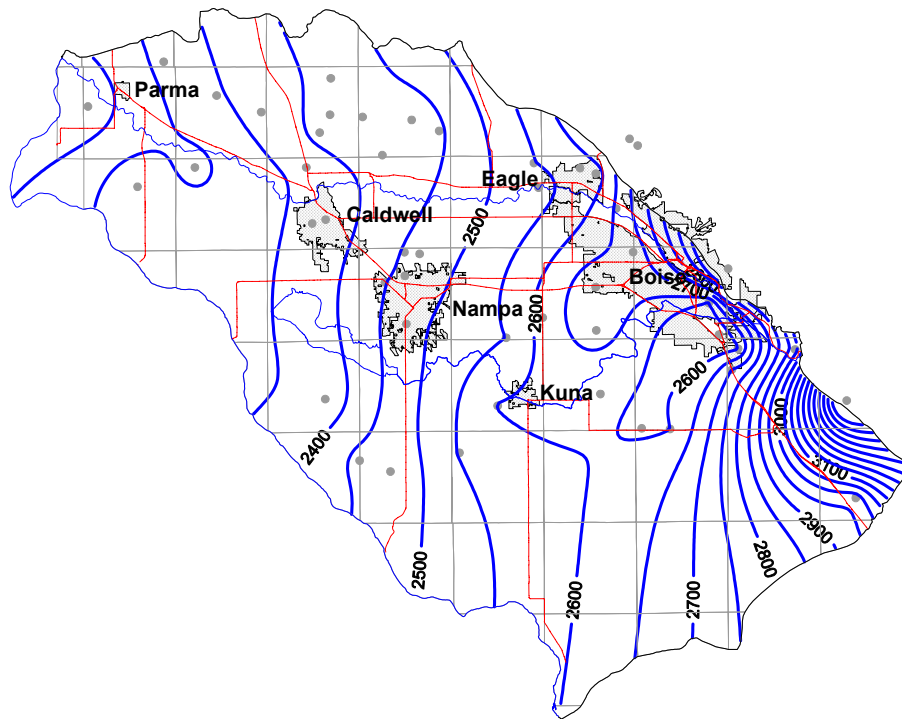

Figure E-5: Fall 1996, intermediate zone (49 wells).

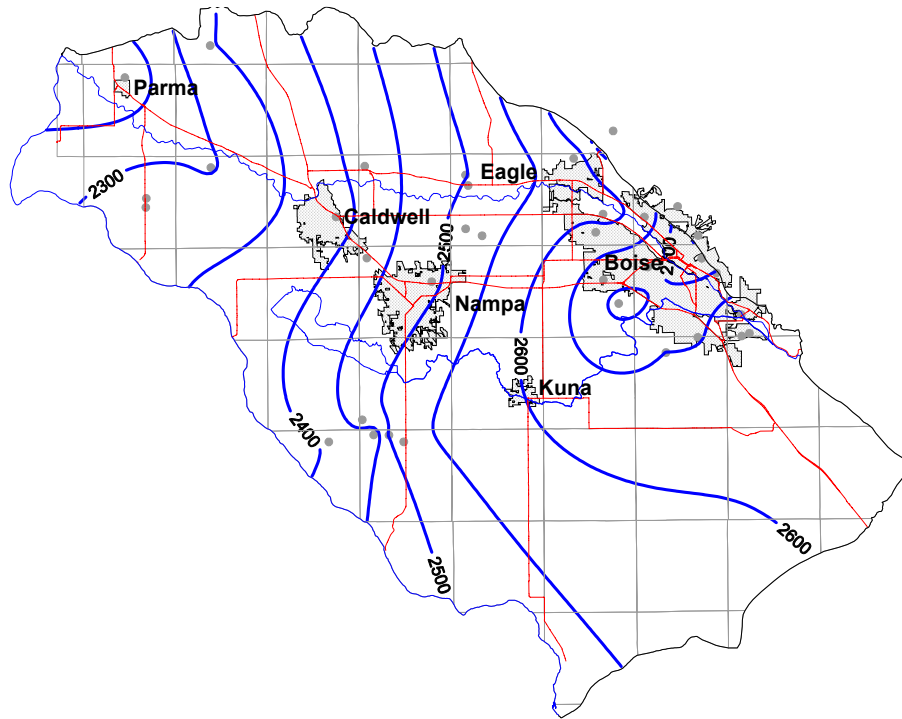

Figure E-6: Fall 1996, deep zone (35 wells).

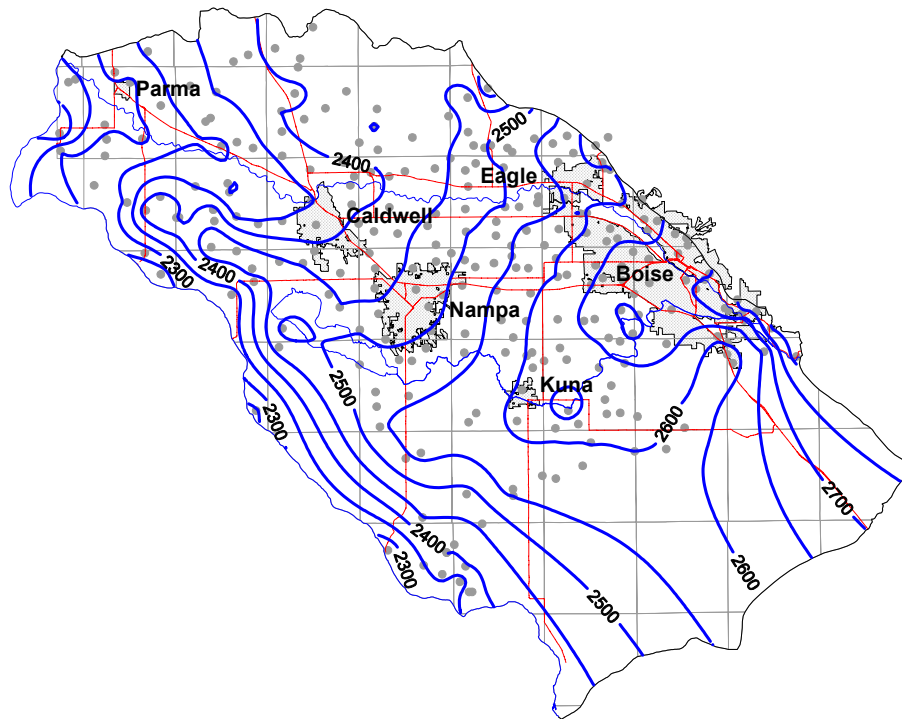

Figure E-7: Spring 1998, shallow zone (259 wells).

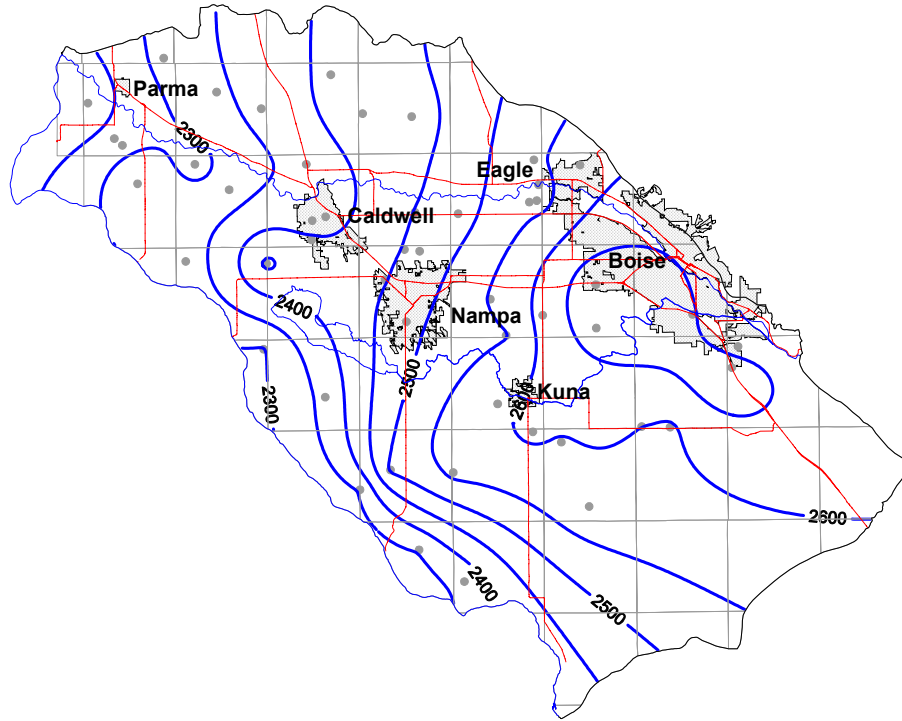

Figure E-8: Spring 1998, intermediate zone (50 wells).

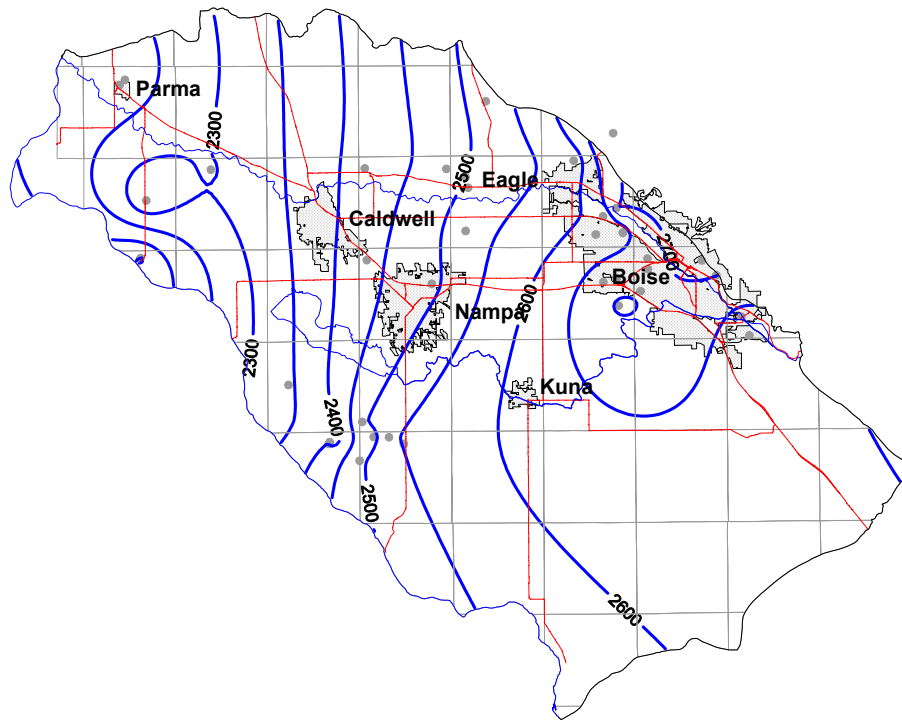

Figure E-9: Spring 1998, deep zone (38 wells).

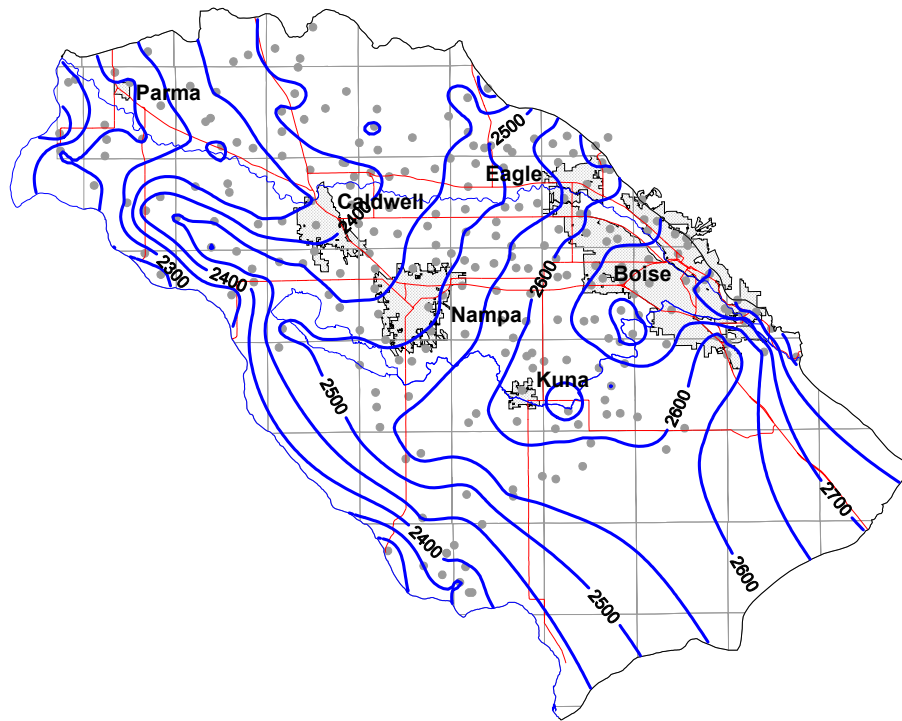

Figure E-10: Fall 1998, shallow zone (245 wells).

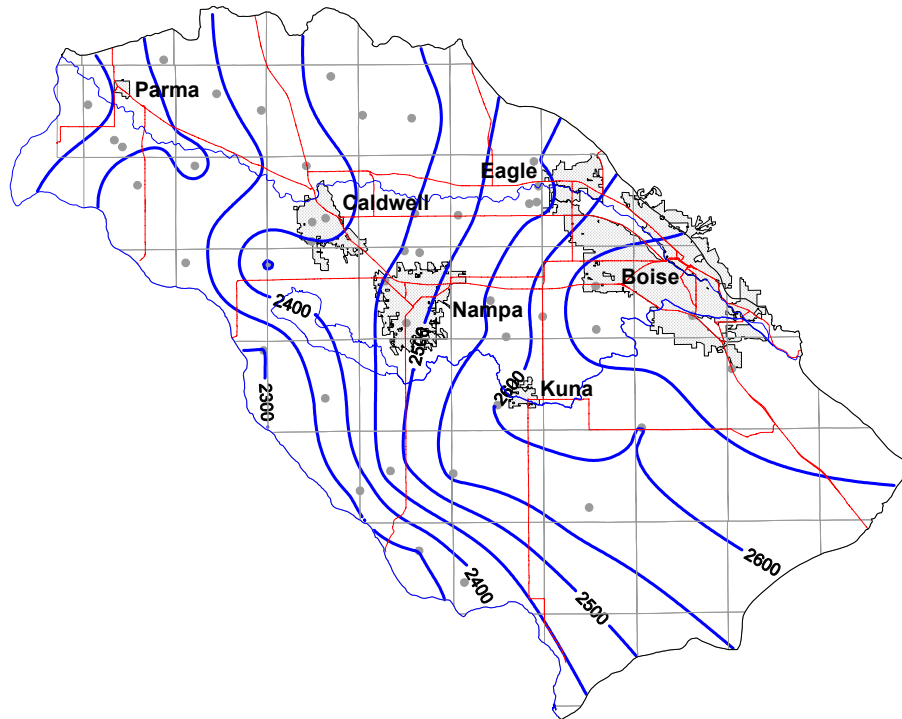

Figure E-11: Fall 1998, intermediate zone (44 wells).

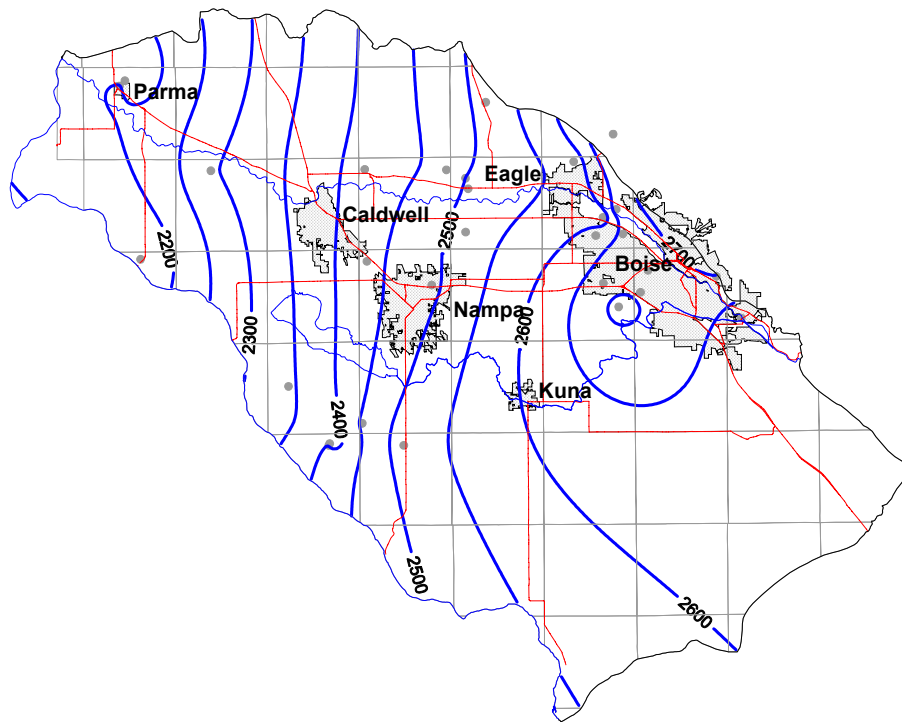

Figure E-12: Fall 1998, deep zone (29 wells).

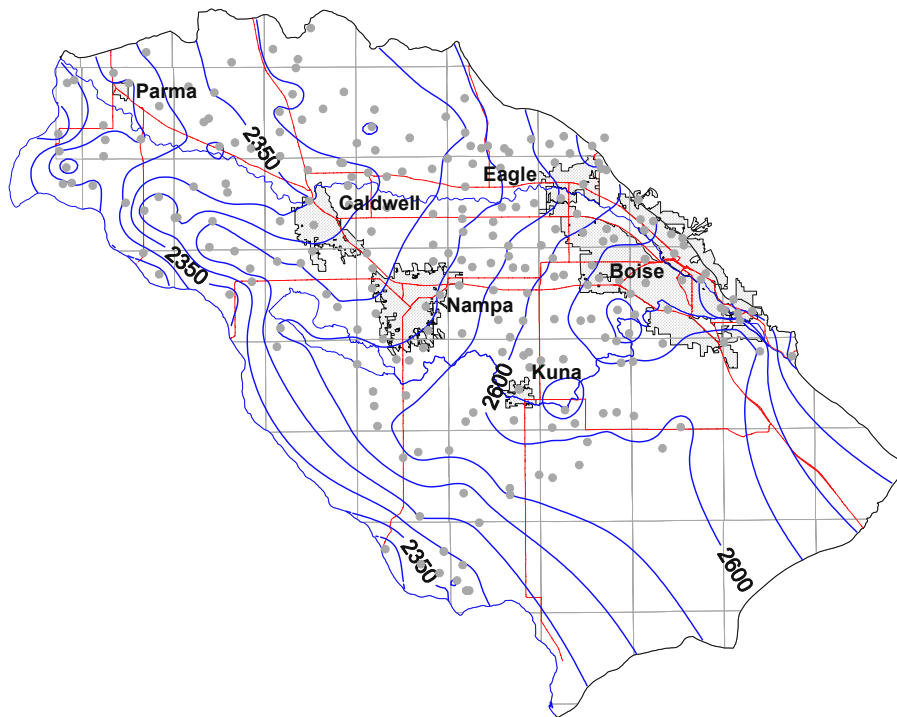

Figure E-13: Spring 2000, shallow zone (238 wells).

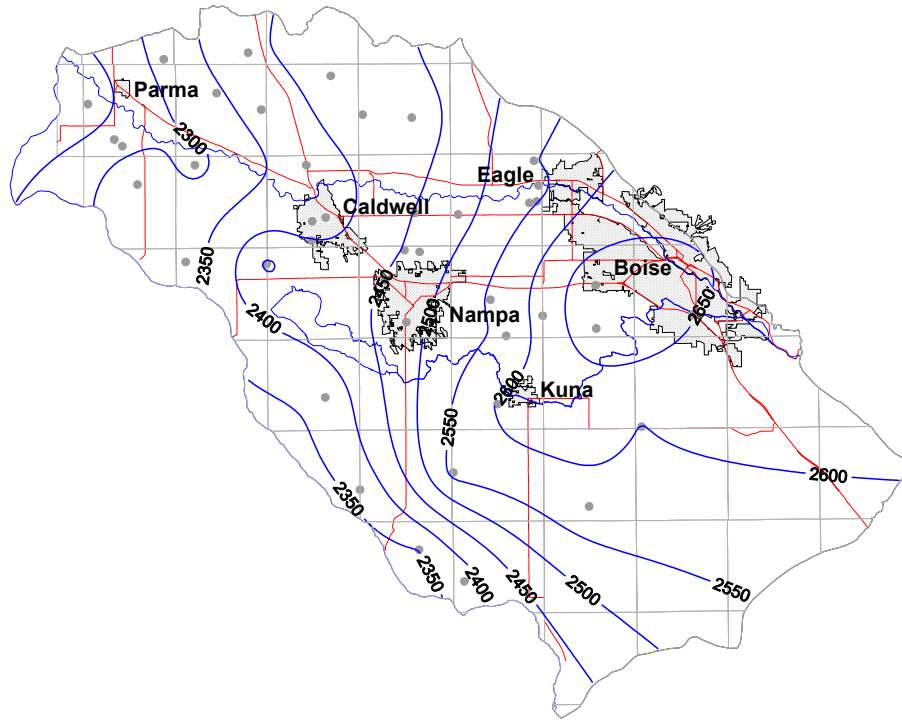

Figure E-14: Spring 2000, intermediate zone (42 wells).

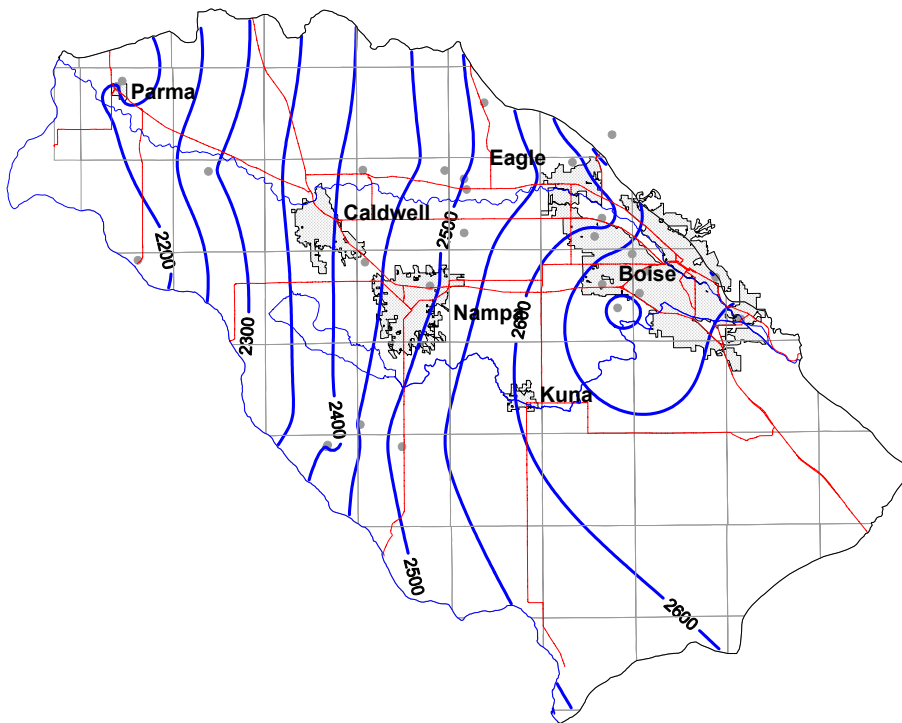

Figure E-15: Spring 2000, deep zone (27 wells).

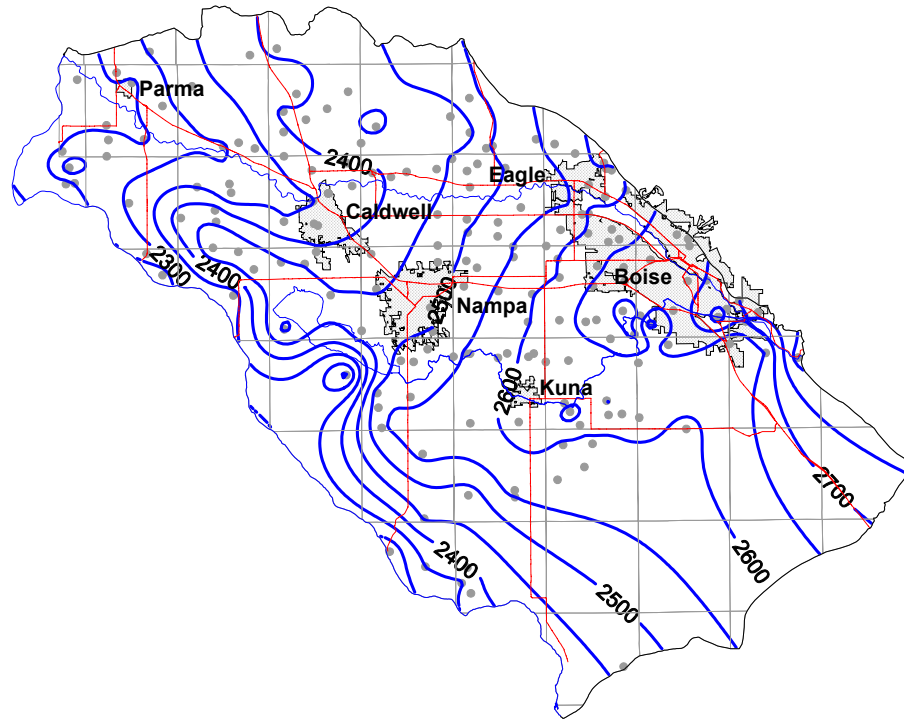

Figure E-16: Fall 2000, shallow zone (16 wells).

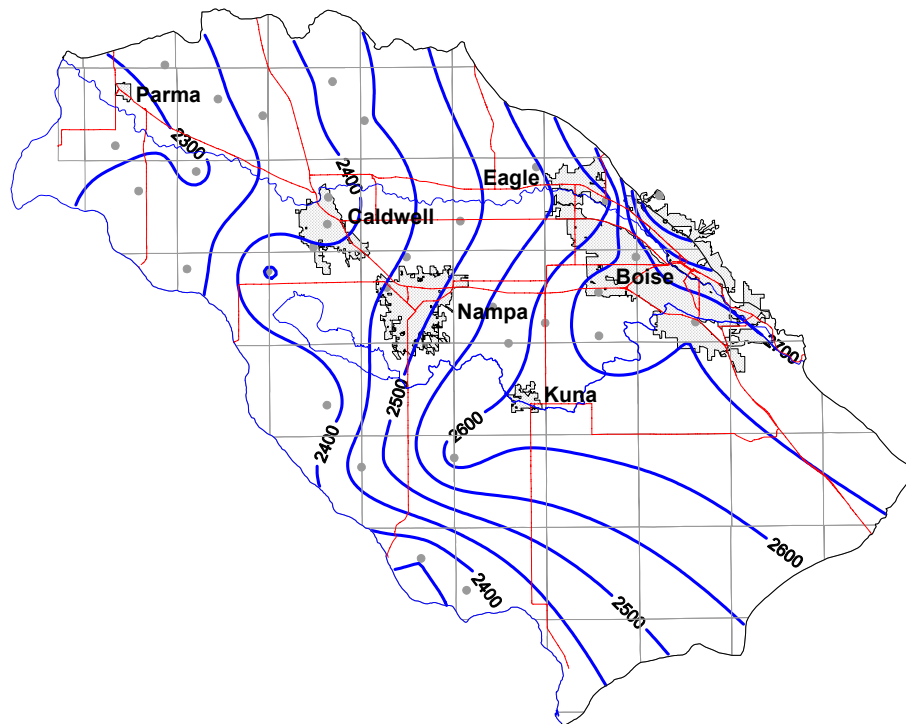

Figure E-17: Fall 2000, intermediate zone (34 wells).

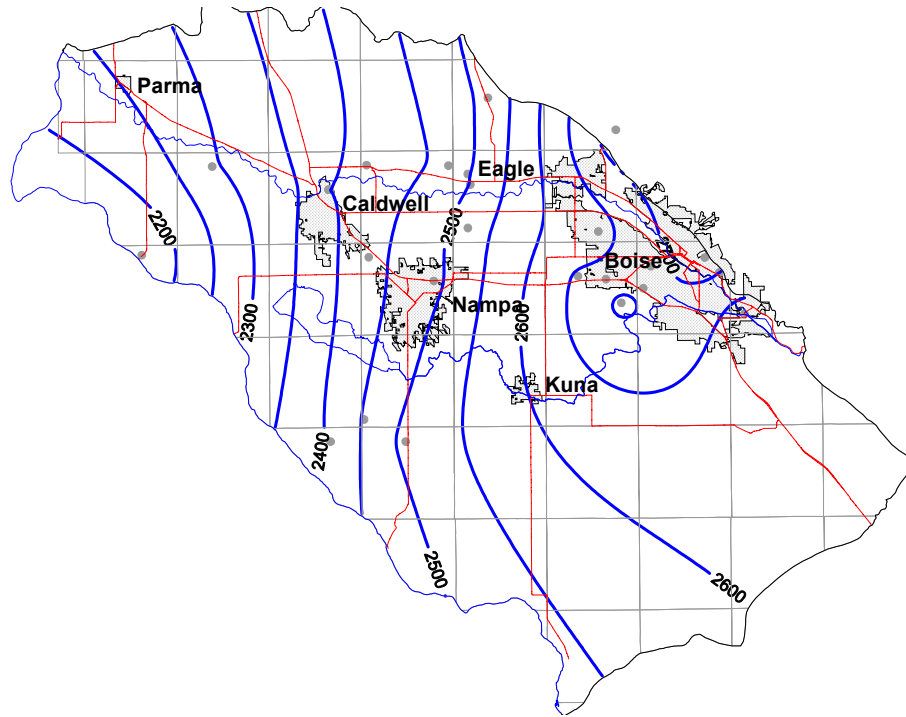

Figure E-18: Fall 2000, deep zone (26 wells).

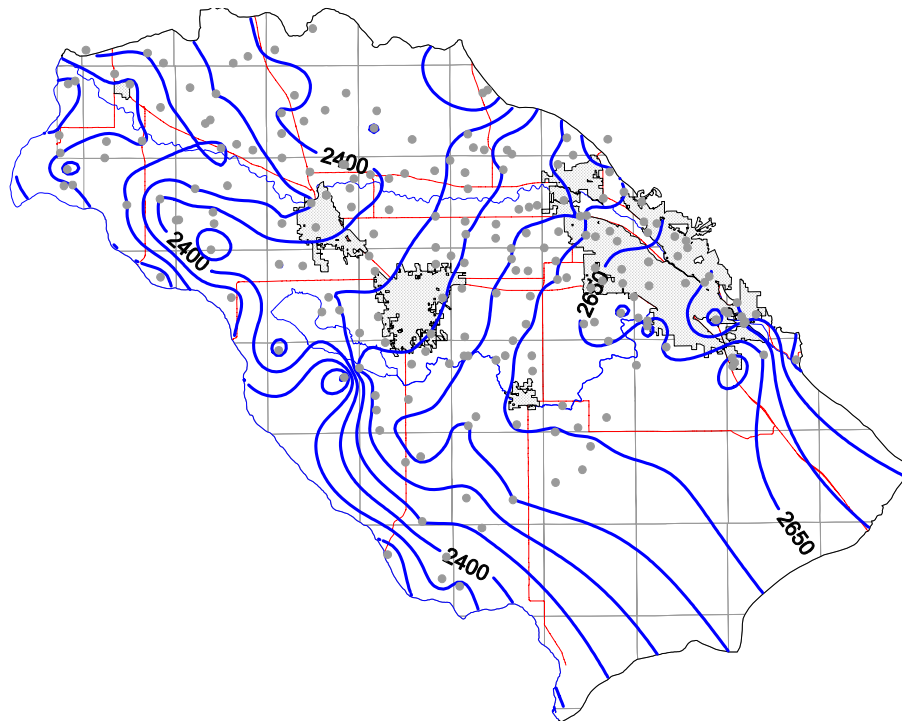

Figure E-19: Fall 2001, shallow zone (212 wells).

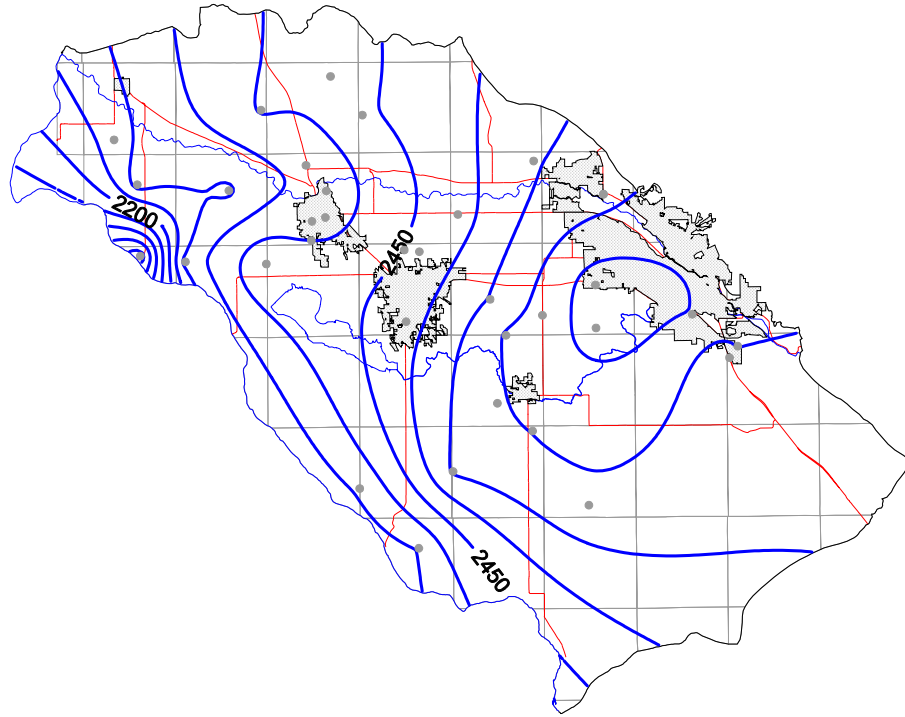

Figure E-20: Fall 2001, intermediate zone (35 wells).

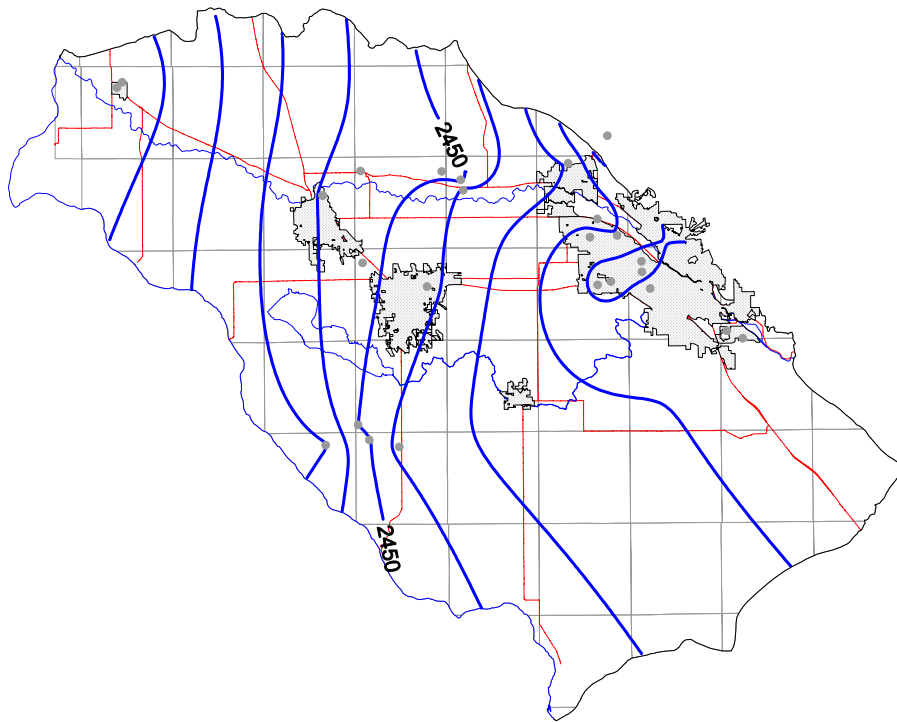
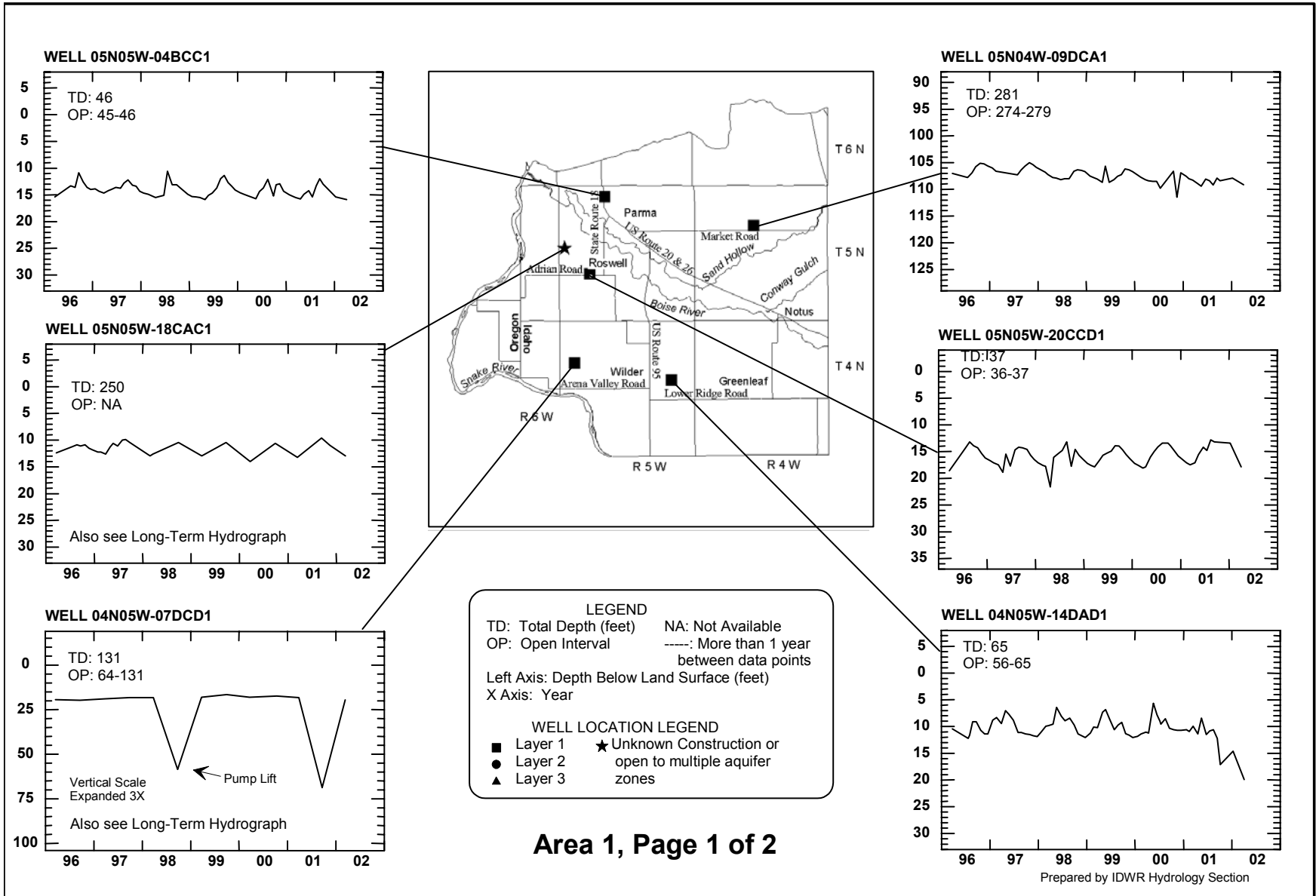
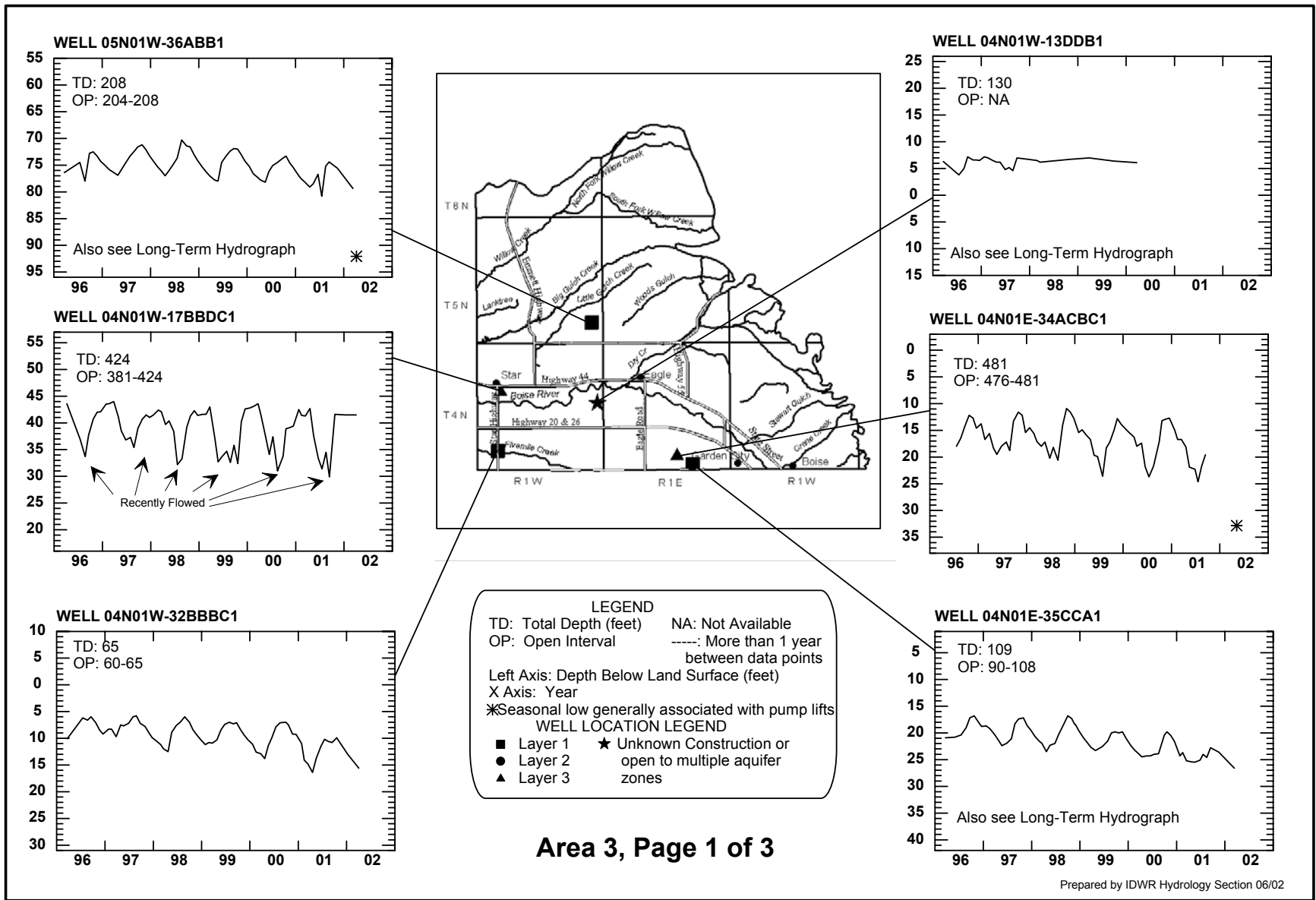

Figure E-21: Fall 2001, deep zone (27 wells).

Appendix F. HYDROGRAPHS





Area 3, Page 1 of 3

Prepared by IDWR Hydrology Section 06/02

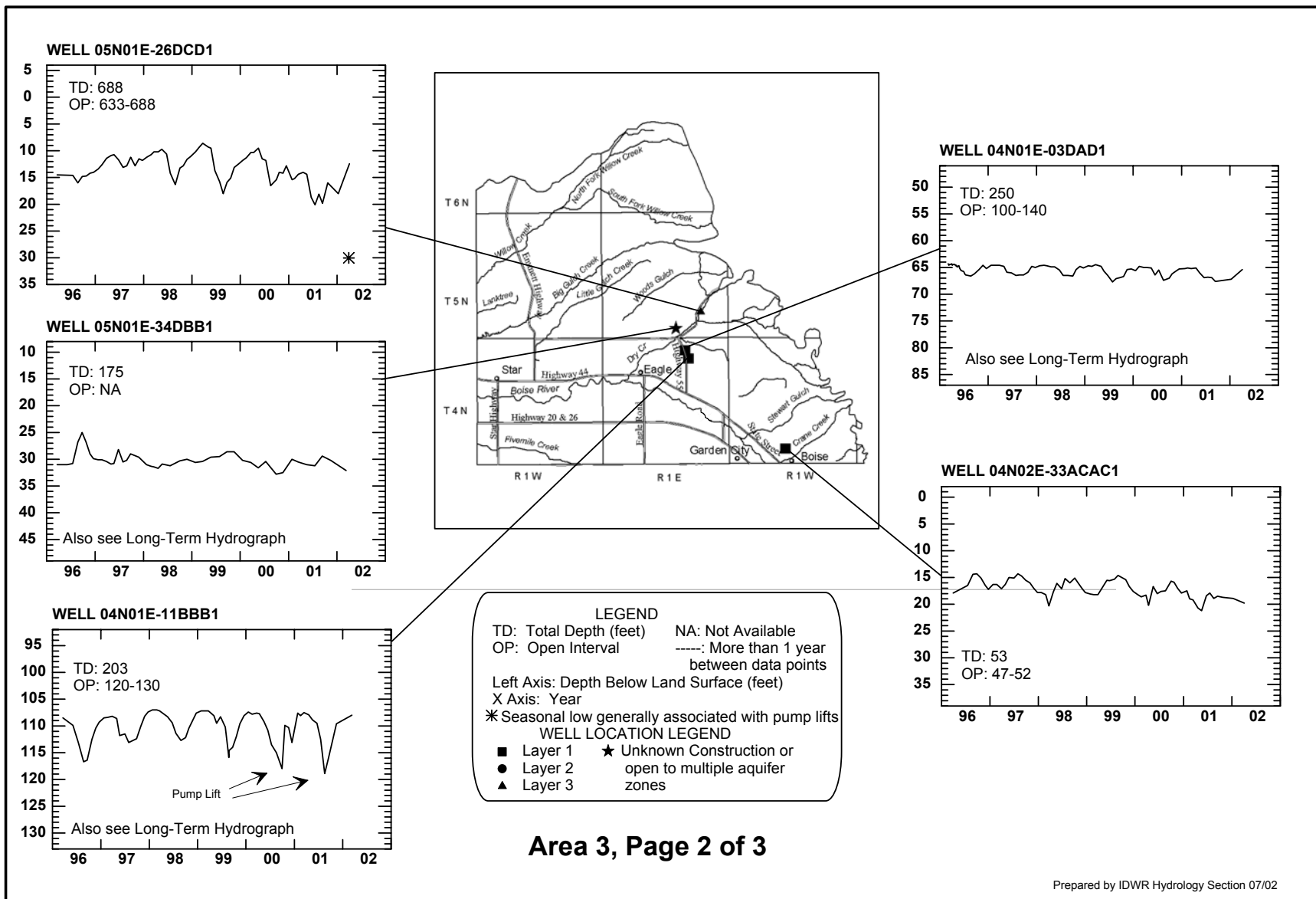

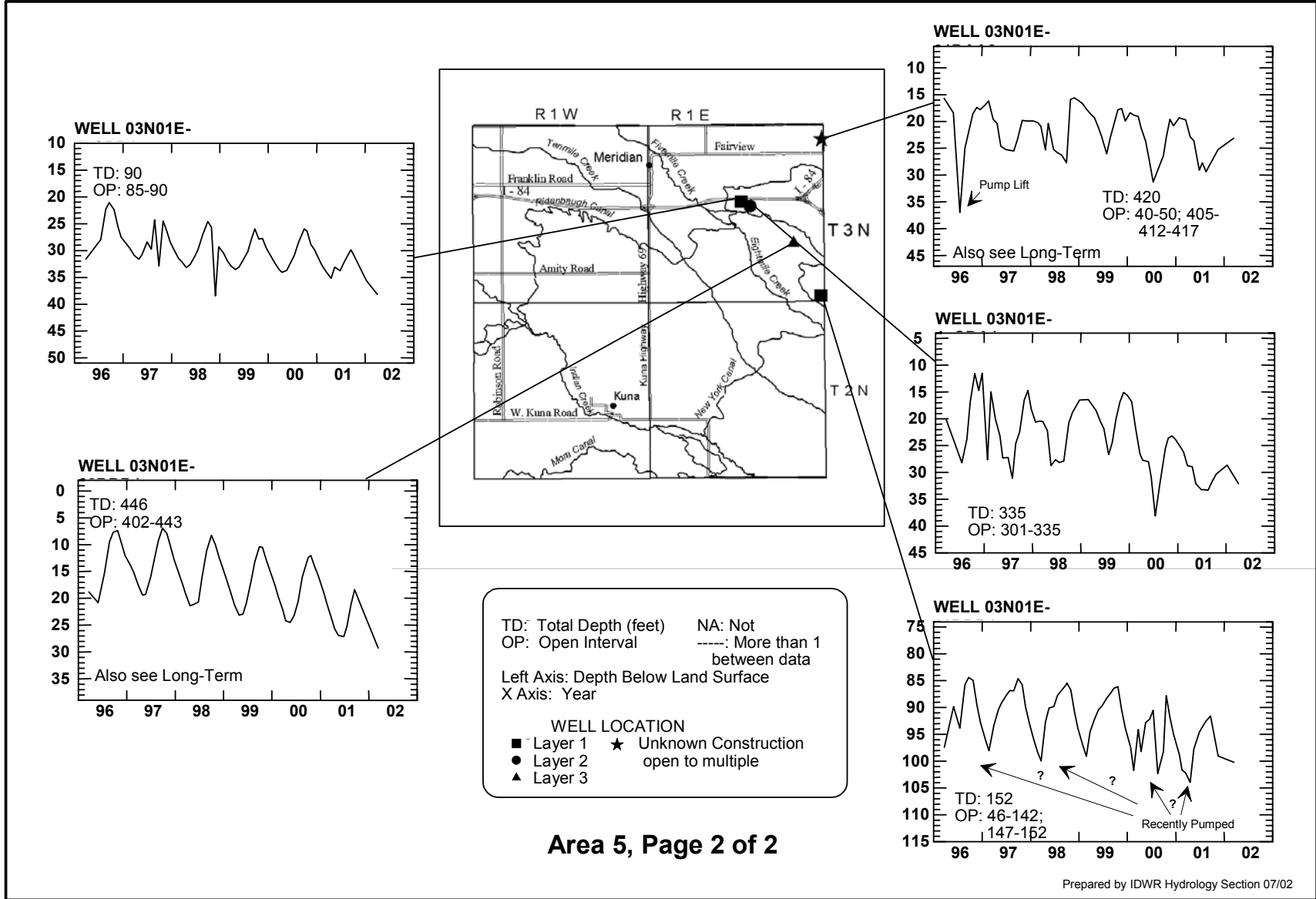

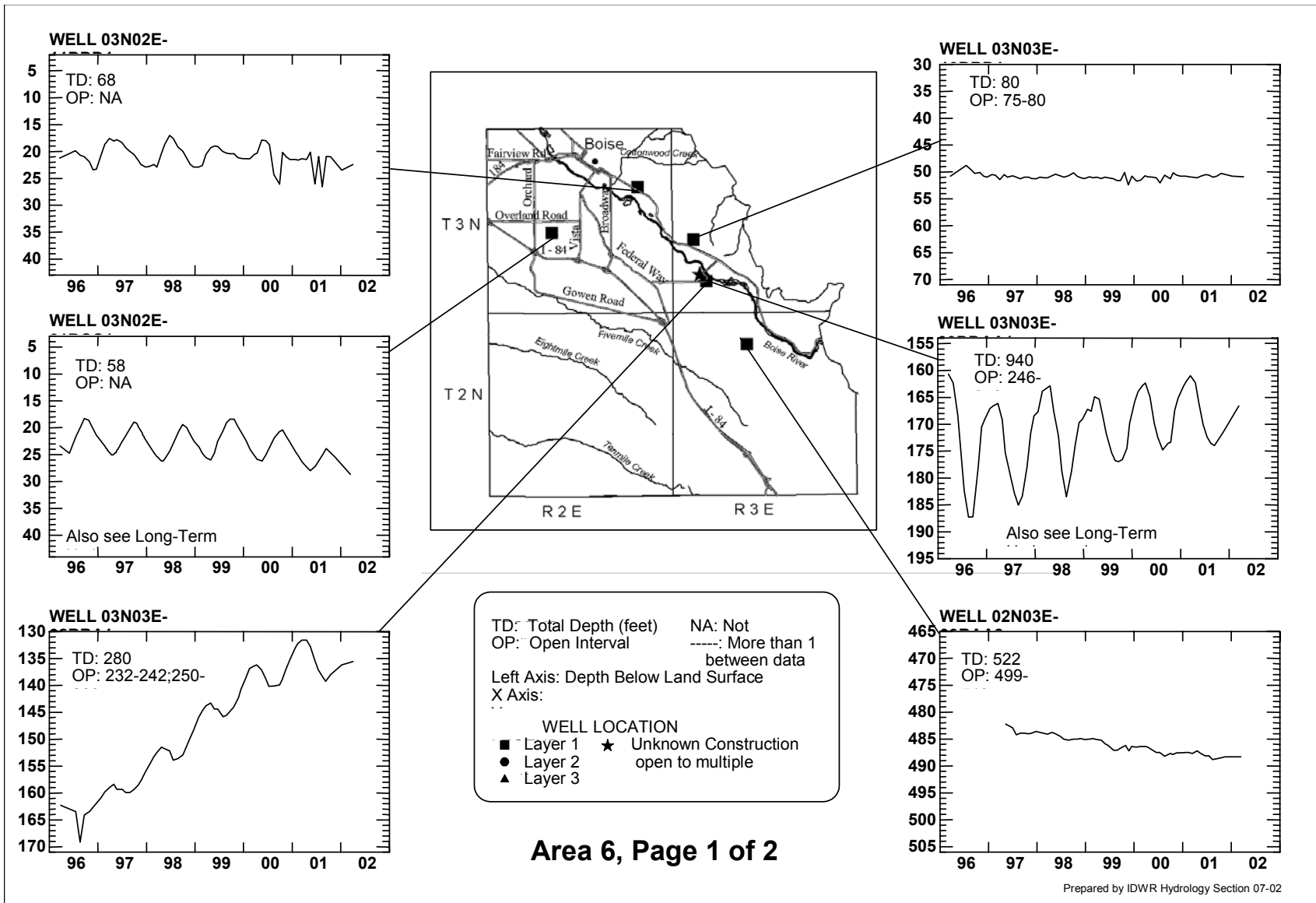

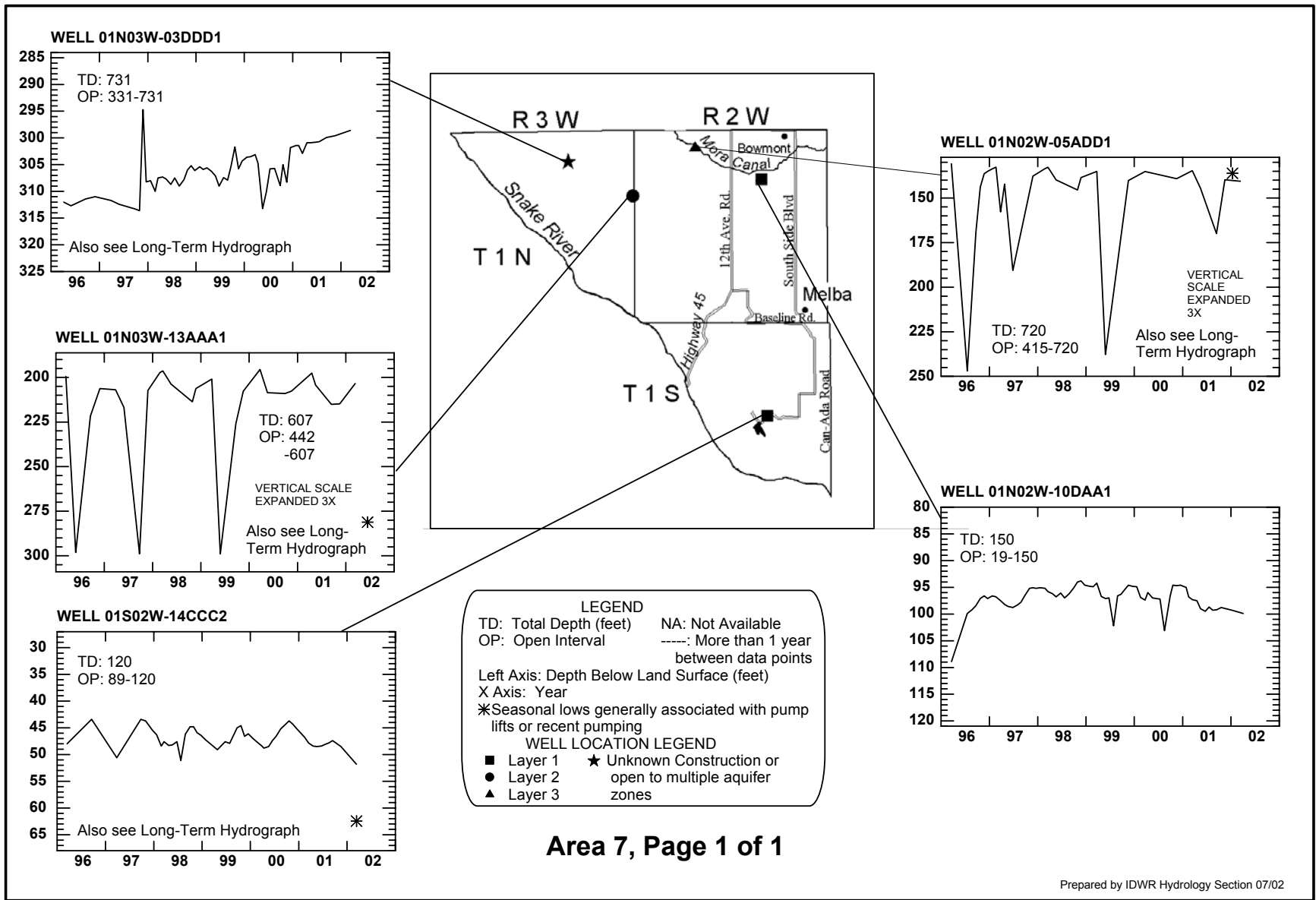

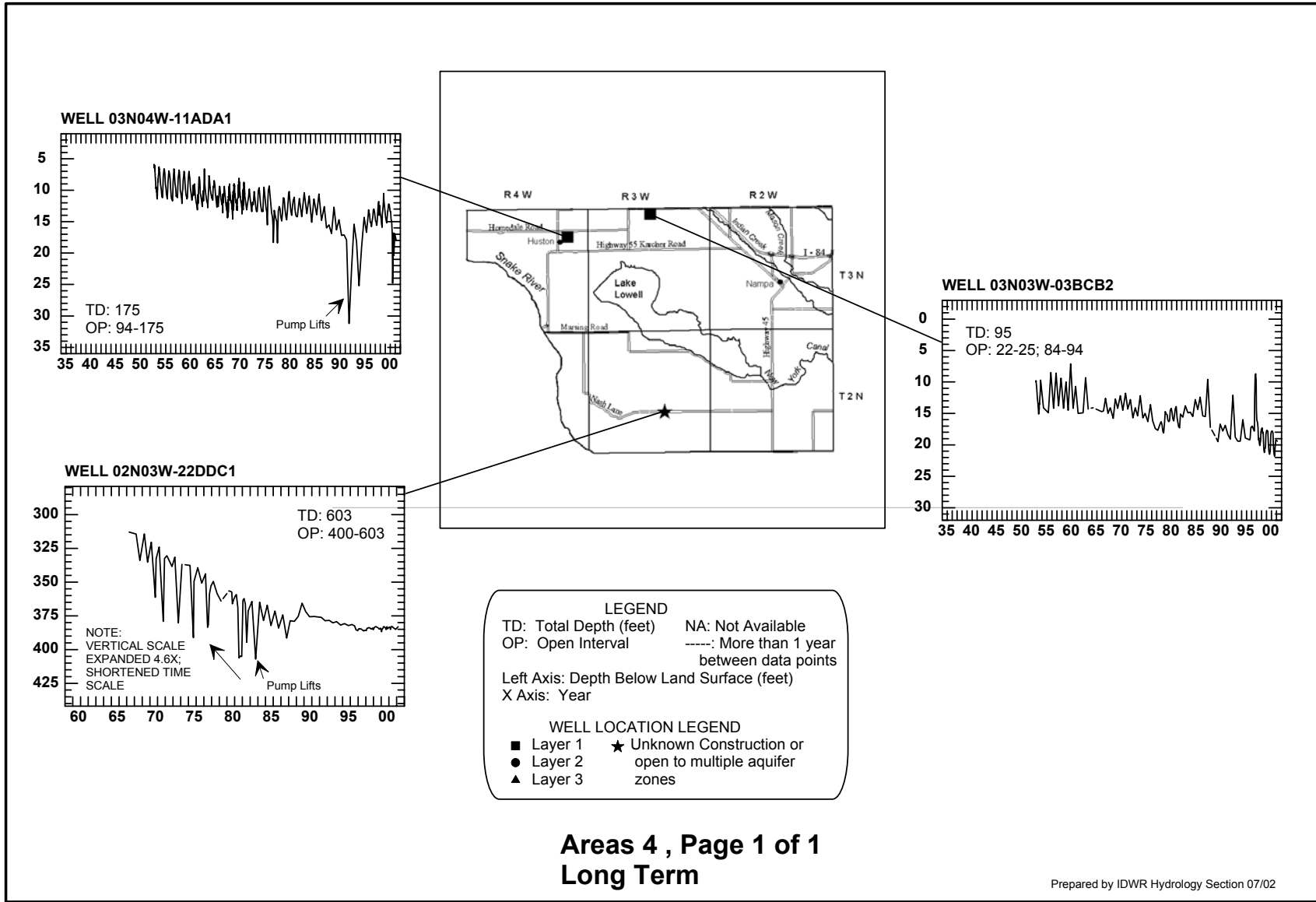

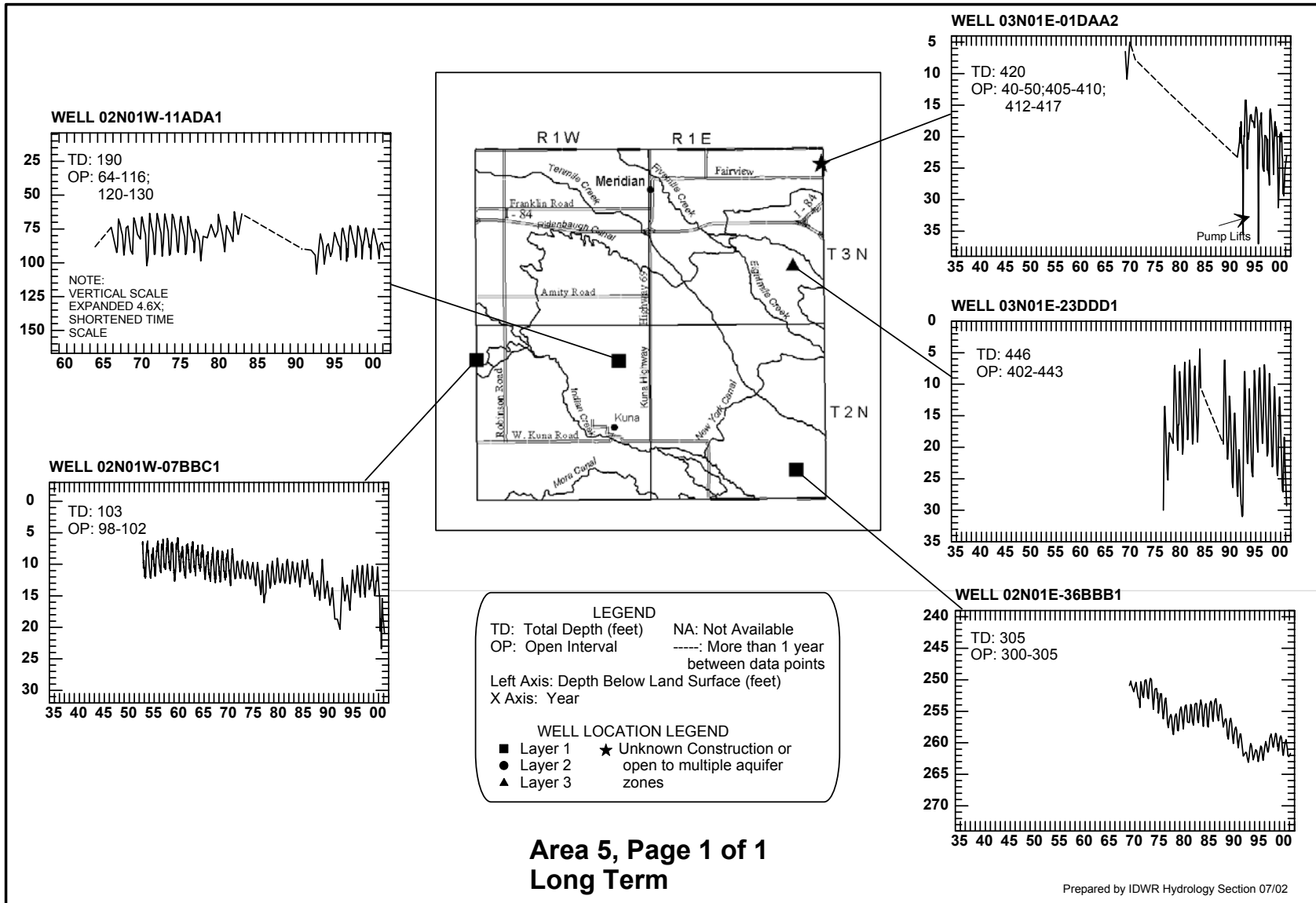

Appendix G. SELECTED HYDROGRAPHS SHOWING CHANGES

This section repeats selected hydrographs that were shown in the previous appendices, but the discussion regarding water level has changed. Locations of the hydrographs included in this appendix are shown below.

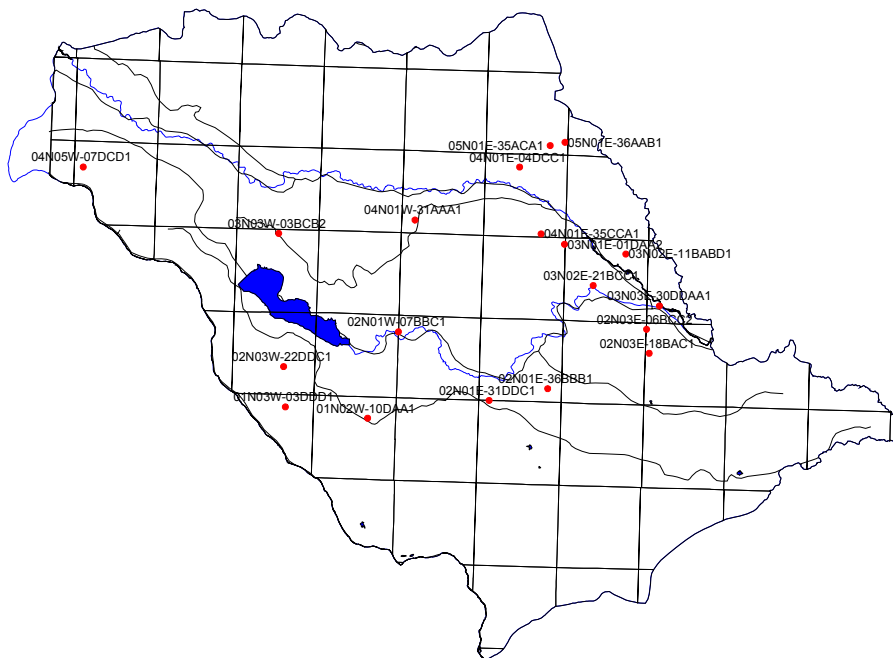

Location of Wells

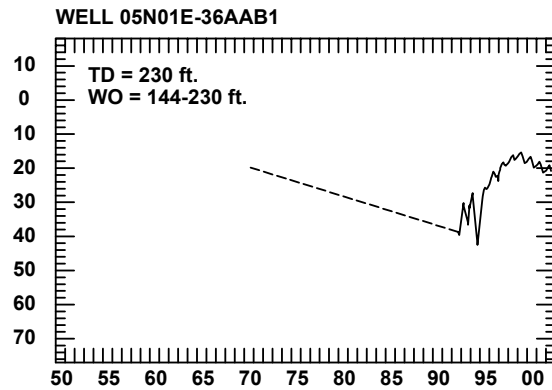
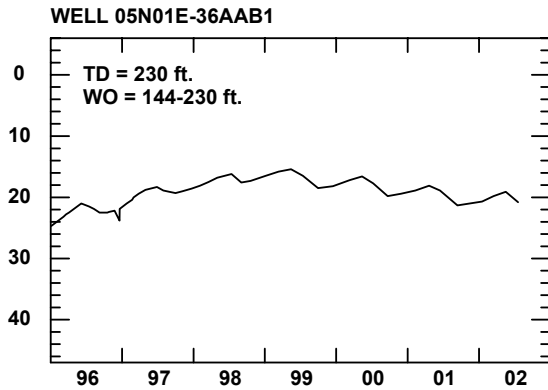

NORTHEAST OF EAGLE, Jeker geothermal well. Per Ken Neely, the increasing shut-in pressures are a result of decreasing production within the geothermal aquifer during the period between 1995 and 1999.

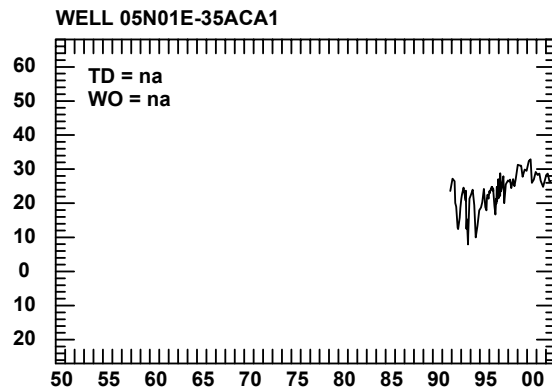
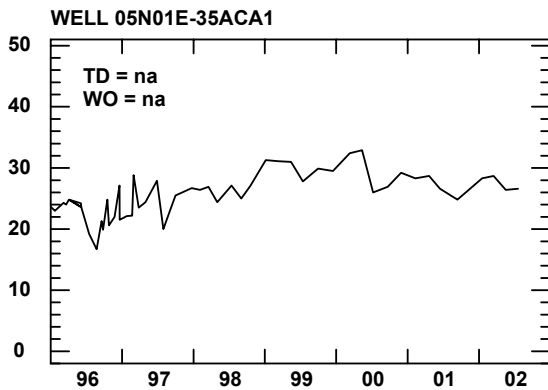

NORTHEAST OF EAGLE (no well log available). Geothermal well showed rises in the shut-in pressuring during the period 1994-1999. From 2000 to present, slight declines have been shown.

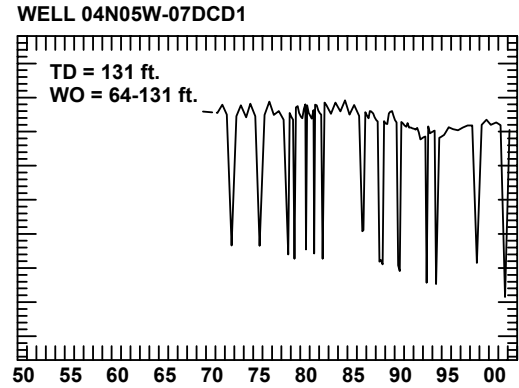
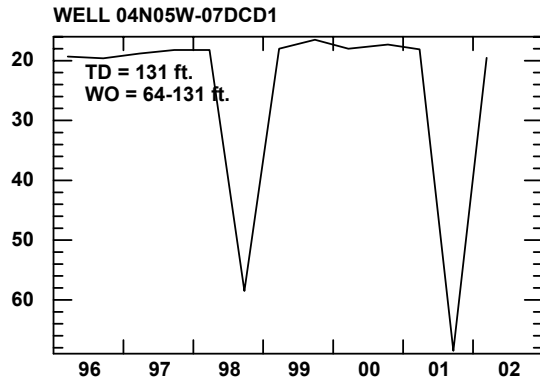

NORTHWEST OF NOTUS, NORTH OF GREENLEAF. Decline from 1985 to 1993–1994, which coincides with below normal precipitation. Increases from 1995 to present coincide with increased precipitation. Hydrograph curves prior to 1985 generally correspond with the precipitation curve.

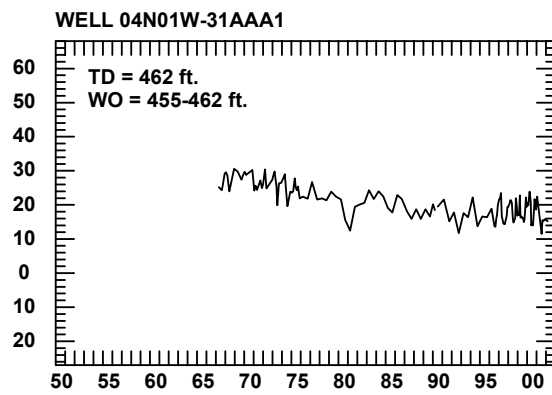
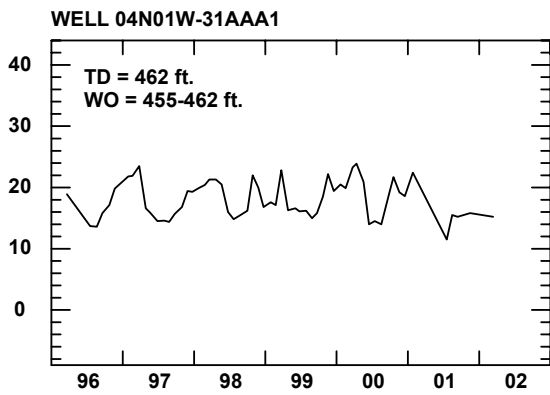

SOUTH OF STAR. Flowing well, apparent decrease in pressure from early 1970s to 1990. Water levels from 1990 to 1998 appear stable to increasing. Well is 5 miles down gradient from Meridian, 2 miles north of I-84 corridor. Land use change map does not indicate major decrease in irrigated lands, but some changes have occurred locally. Water levels may have come to equilibrium. Five-foot decline over past 3 years beginning in 1999 may indicate a renewed period of decline.

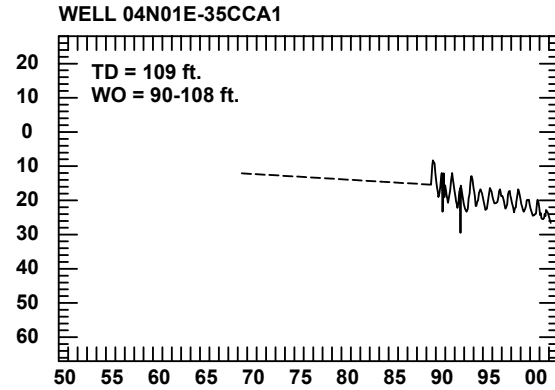
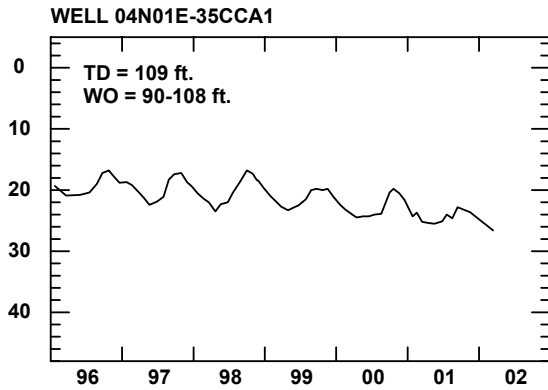

WEST OF GARDEN CITY, 3 miles. Vicinity of Ustick & Five Mile Road. Suburban development since late 1980s or early 1990s. Formerly irrigated farmlands. Leveled off 1996–1998. Has been declining since 1998.

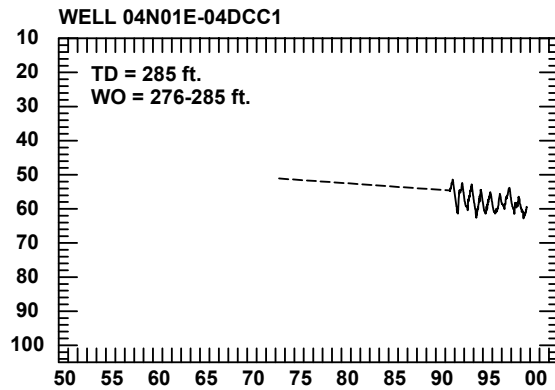
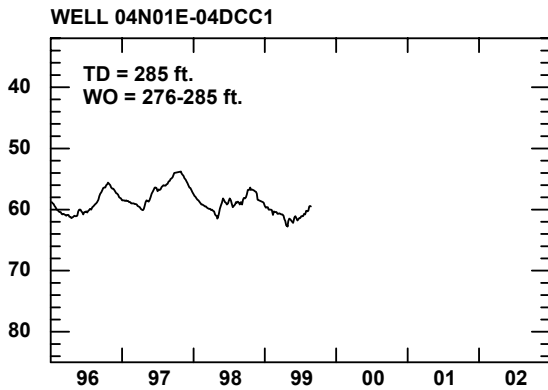

NORTH OF EAGLE. Suburban development since late 1980s to present. Formerly irrigated farmland. Slight declines continue.

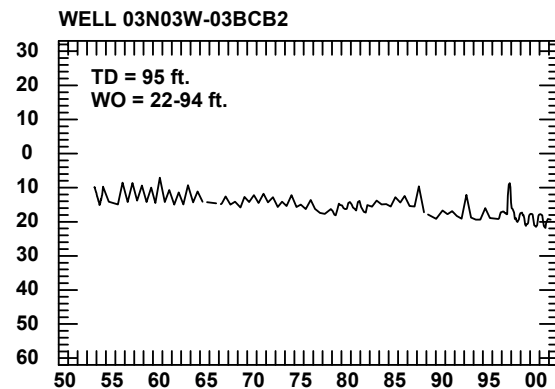
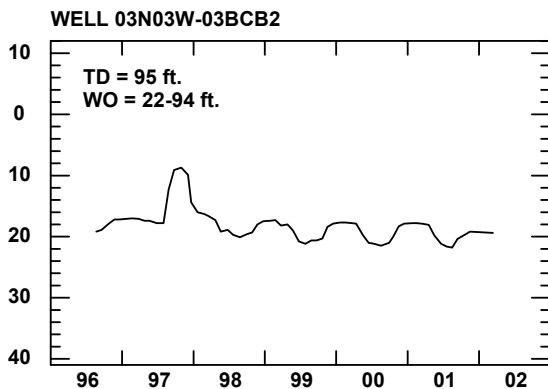

Field visit shows current high density housing construction surrounded by flood-irrigated lands and older residential tracts. Long-term decline probably resulting from gradual increase in housing throughout this area.

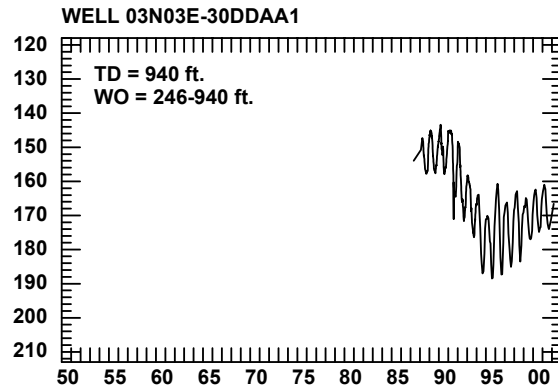
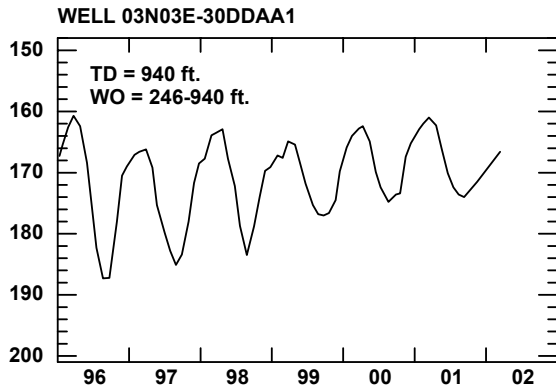

EAST BOISE TEST WELL. Water levels are indicative of the declining water levels and subsequent increasing trends since 1999 in the southeast Boise area surrounding the Micron facility.

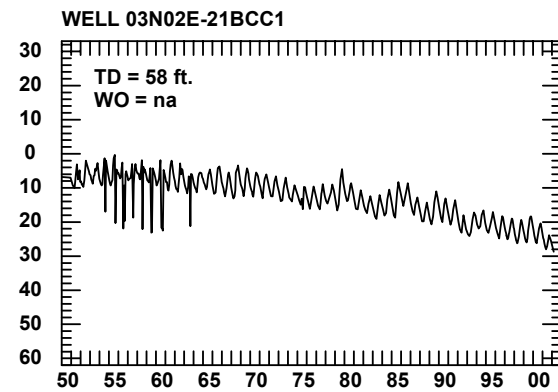
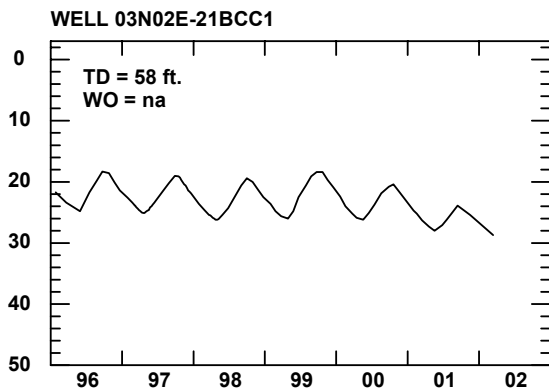

BOISE, NEAR HILLCREST GOLF COURSE. The golf course was built around 1962; the neighborhood looks to be 1945+ era. Water level increased until 1955, when a steady decline of 1-2' per year began and has continued. Also, New York Canal is within 1 mile south of the site but has been lined since approx 1907 (D. Dyke, pers. comm.). Decline may be result of nearby (?) residential well use.

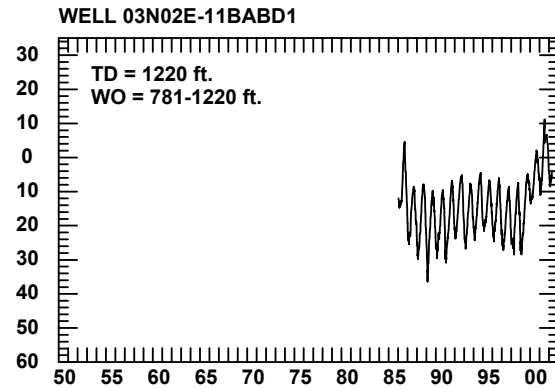
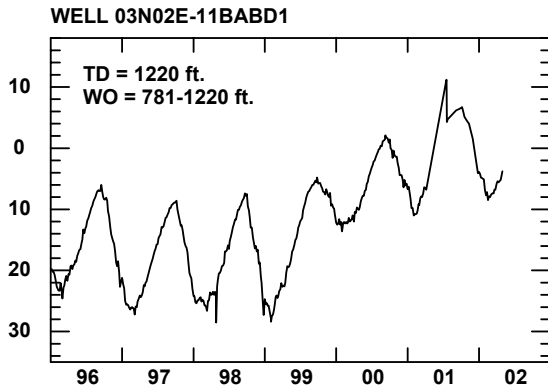

BLM GEOTHERMAL WELL. Declines in pressures correspond to other wells in the geothermal aquifer. Declines appear to have stabilized through the aquifer. Increasing water levels since 1999 may be influenced by the injection of spent geothermal water from the Boise City geothermal system. Injection began in 1999.

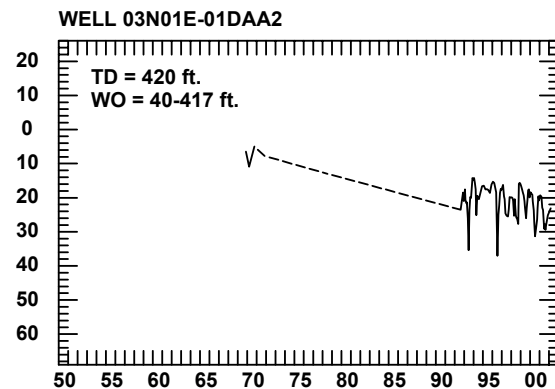
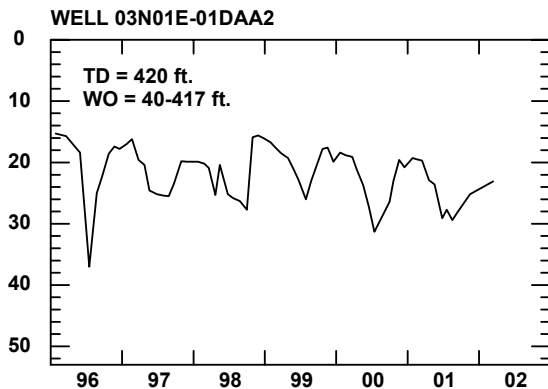

EAST OF MERIDIAN, NORTH OF FAIRVIEW. Reduction in flood irrigation combined with increased urbanization is most likely cause of water level decline.

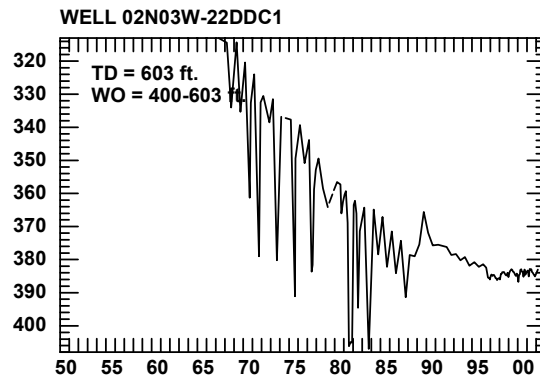
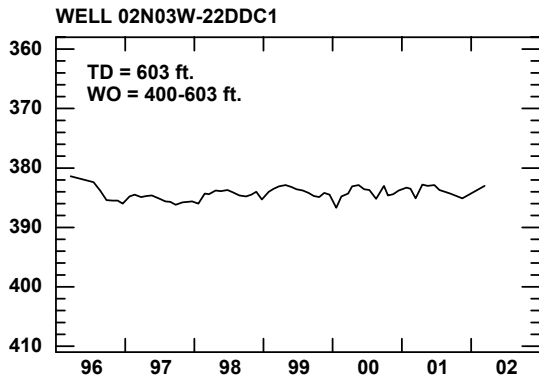

SOUTH OF LAKE LOWELL. Sprinkle irrigated farmland; mostly with ground water (per land use mapping). Fallow land to north and west, no flood irrigation available. Decline from mid-1960s to mid-1990s probably resulting from steady ground water over use coupled with low recharge rates. Water levels stabilized since mid-1990s.

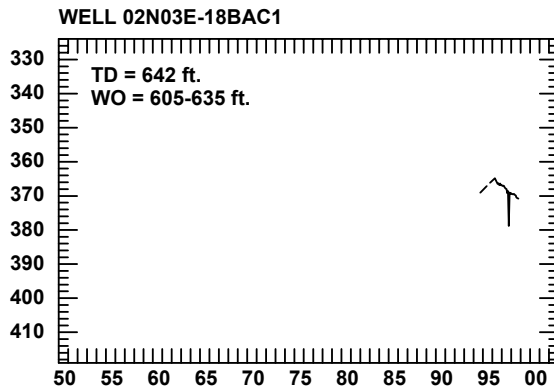
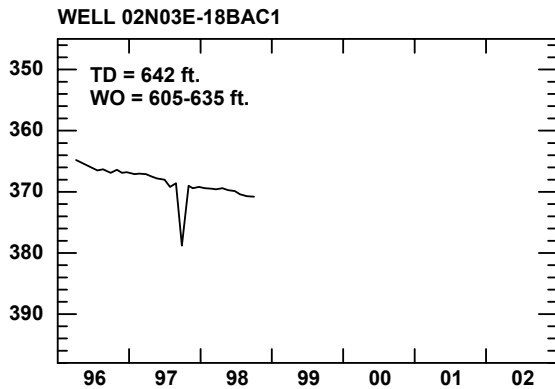

SOUTH OF BOISE, SOUTH OF FIVE MILE CREEK. Knox well, located on hill near Micron. Limited data, and no new data since 1998. Declines possibly resulting from increased water use in Micron vicinity or use at the well site itself.

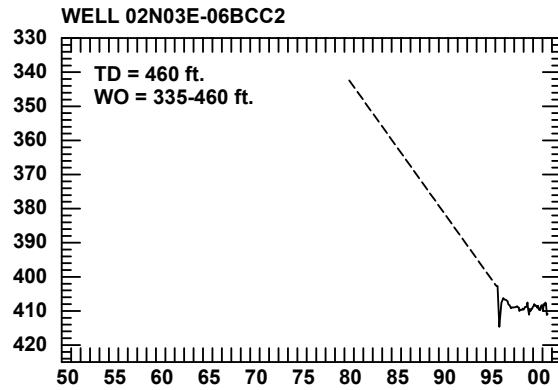
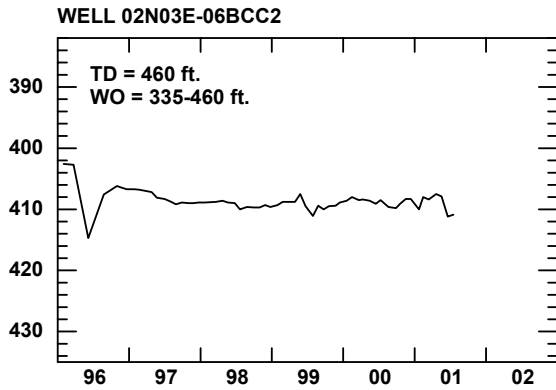

GOWEN ROAD & FEDERAL WAY, KOA well. Located near SE Boise GWMA. Major declines have been observed throughout this area. This decline probably resulted from major increase in water use in the Micron vicinity. Water levels have stabilized since 1996.

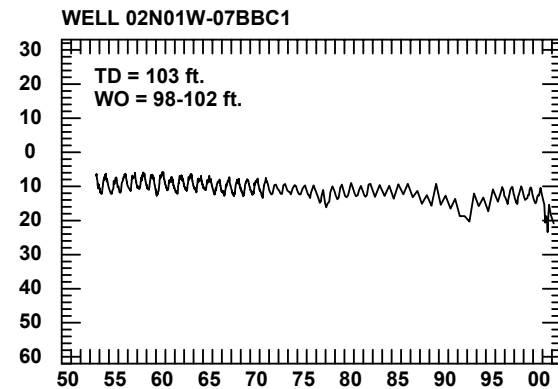
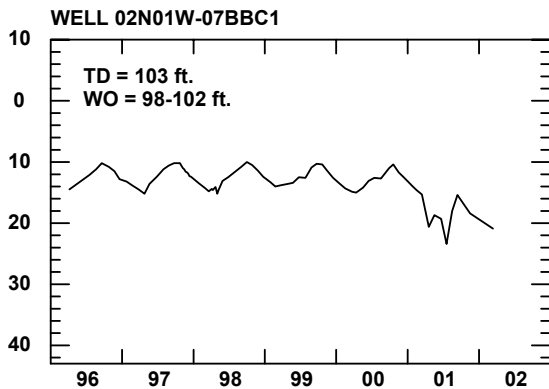

NORTHWEST OF KUNA, WEST OF ROBINSON ROAD. This section is mostly flood-irrigated farmland with houses along the perimeter. Age of houses range from pre-1940 to present. Gradual decline of water level probably result of gradual increase in residential construction. Sharp declines in 1990 and 2001, probably drought related.

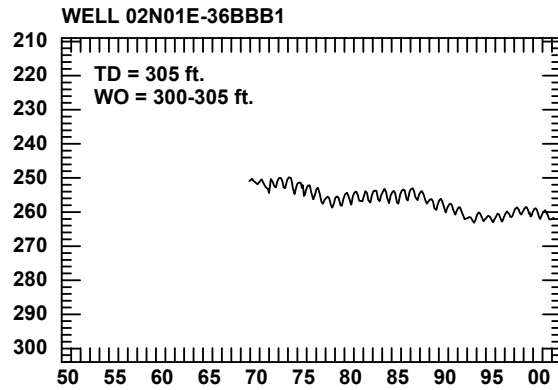
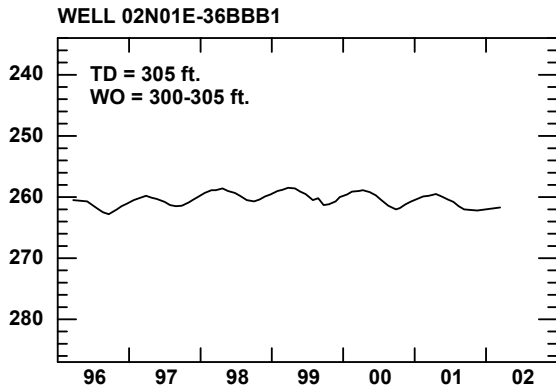

EAST OF KUNA 6 MILES, SOUTH OF NEW YORK CANAL. General long-term decline, punctuated by period of recovery that coincide with years of above normal precipitation.

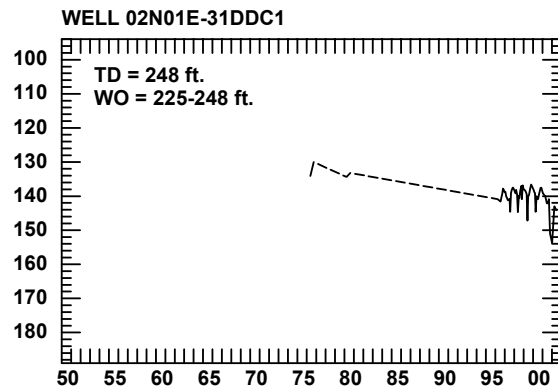
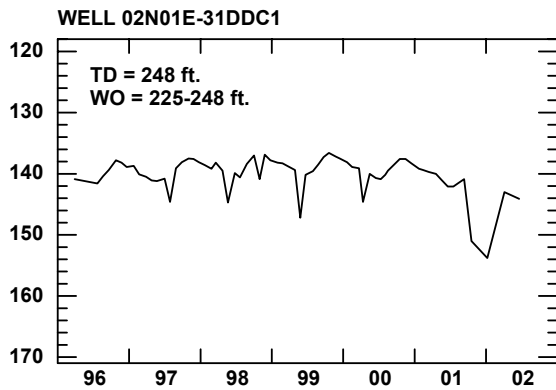

SOUTHEAST OF KUNA. Fairly stable from 1996 through 2000. Data are too limited to determine cause of declines prior to 1996.

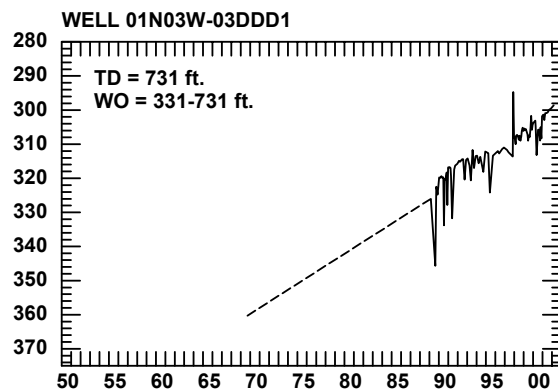
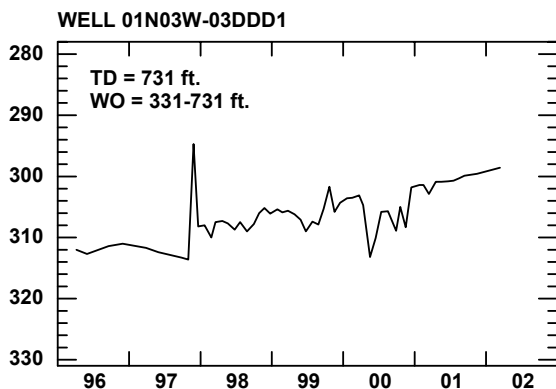

NEAR SNAKE RIVER, WEST OF MORA CANAL. Unclear reason for sharp increase in water level. Several injection wells (total depths approximately 100-150') are used for disposal of field runoff nearby.

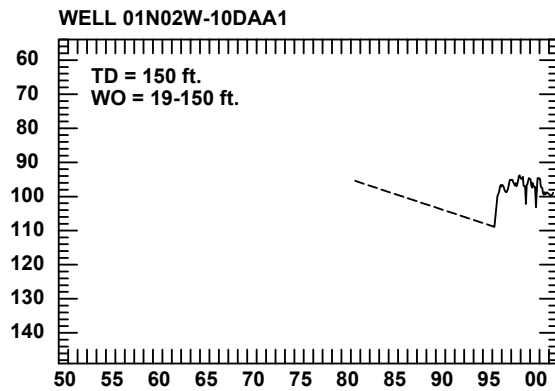
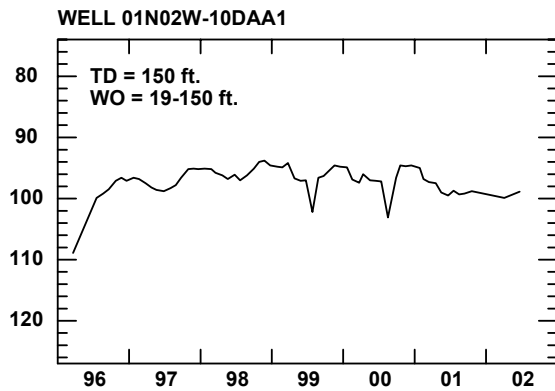

NORTH OF MELBA, NEXT TO MORA CANAL. Short record of data. Relative to 1980 USGS measurement, current water levels have not changed substantially. Continued increases may be due to above average precipitation during mid- to late-1990s. Recent levels appear to reflect drier-than-normal conditions.

Costs associated with this publication are available from the Idaho Department of Water Resources in accordance with Section 60-202, *Idaho Code*. IDWR-21000-20-03/2004.