

# METHODS AND TECHNIQUES FOR STUDYING AND CENSUSING RIVER OTTER POPULATIONS

Wayne E. Melquist  
Maurice G. Hornocker

IDAHO COOPERATIVE  
WILDLIFE RESEARCH UNIT



FOREST, WILDLIFE AND RANGE EXPERIMENT STATION



TECHNICAL REPORT 8

MARCH 1979



University of Idaho

Moscow, Idaho 83843

# **METHODS AND TECHNIQUES FOR STUDYING AND CENSUSING RIVER OTTER POPULATIONS**

by

**Wayne E. Melquist  
Maurice G. Hornocker**

March 1979



## ACKNOWLEDGMENTS

Financial support was provided by the U.S. Fish and Wildlife Service, the Idaho Department of Fish and Game, and the University of Idaho Research Council. We thank J. Antle, J. Johnston, R. Olson, B. Whitman, J. Whitman, and K. Wynn for field assistance. J. Hait generously provided housing and facilities. T. Dunstan assisted in developing telemetry techniques. G. Smith, DVM, and his staff provided professional assistance and took personal interest in the entire project. The YACC program, U.S. Fish and Wildlife Service, has provided employees, operating funds and equipment since March 1978.



The Idaho Cooperative Wildlife Research Unit is supported by the U.S. Fish and Wildlife Service, University of Idaho, and the Idaho Department of Fish and Game, and Wildlife Management Institute.



The material in this report has received internal processing through the Wildlife Resources program and is issued as a non-refereed publication of the Forest, Wildlife and Range Experiment Station, University of Idaho, Moscow.

Contribution No. 154

Forest, Wildlife and Range Experiment Station

University of Idaho

## Table of Contents

	Page
ACKNOWLEDGMENTS	
INTRODUCTION . . . . .	1
CAPTURE METHODS . . . . .	1
Leg-hold trap . . . . .	1
Foot snare . . . . .	2
Tomahawk trap . . . . .	2
Culvert trap . . . . .	3
Barrel trap . . . . .	3
Hancock trap . . . . .	3
Floating trap . . . . .	5
CARE AND HANDLING . . . . .	6
Drugging . . . . .	6
Handling . . . . .	6
TELEMETRY . . . . .	8
Collars . . . . .	8
Implants . . . . .	8
IMPLANT PROCEDURES . . . . .	9
POPULATION STRUCTURE . . . . .	11
CENSUS TECHNIQUES . . . . .	11
Capture data . . . . .	11
Visual observations . . . . .	13
Tracks, scats, and other sign . . . . .	13
RECOMMENDATIONS . . . . .	14
CONCLUSIONS . . . . .	15
LITERATURE CITED . . . . .	16
APPENDIX: AVAILABILITY OF MATERIALS AND EQUIPMENT . . . . .	17

# Methods and Techniques for Studying and Censusing River Otter Populations

## INTRODUCTION

On 11 April 1977, the Fund for Animals submitted a petition to the Secretary of the Interior to protect the river otter (*Lutra canadensis*) as an endangered species, pursuant to the Endangered Species Act of 1973. As a result, the Interior Department's U.S. Fish and Wildlife Service began a review to determine the status of the otter in the United States. At that time, only a meager amount of scientific data was available for use in assessing the otter's status. State agencies soon realized they knew little about otter density and distribution in their states. This prompted a new interest in otter research throughout the country, in turn creating a need for useful research techniques.

We have conducted research on river otter in west-central Idaho since June 1976. During this time, we have developed certain techniques that may be useful to researchers who wish to capture, handle, mark, instrument and census river otter.

Some of these techniques will be widely applicable, while others likely will need modification to conform to the area.

## CAPTURE METHODS

In other studies, a variety of methods have been employed to capture river otter without harming the animals. Most sets do not require bait since otter generally catch their own food. In Michigan, otter were obtained for pen studies by removing young from a den, live-trapping them using #4 jump-traps on spring poles, and through the use of wire landing nets (Harger 1961). Stephenson (pers. comm.) used #2 jump-traps successfully in Ontario, Canada. In Newfoundland, Canada, Hancock livetraps were effectively used to capture river otter (Northcott and Slade 1976), while the Bailey livetraps proved very ineffective. In Pennsylvania, Eveland (1978) tested the feasibility of foot snares, padded #3 Victor jump-traps, and #2 double longspring traps, as well as the Hancock livetraps. Three captures were made in the leg-hold traps, with a suspected 21 escapes. Although Eveland only experimented with these traps on a limited basis, he felt that foot snares, when properly modified, could provide a safe, effective, and easy-to-use trapping method for river otter. In this study, a variety of trap designs have been used to capture otter.

### Leg-hold Trap

We began in June 1976, using only leg-hold traps. After June 1977, these traps were used only in certain situations (e.g., where preferred traps could



not be used). When set in places where otter were known to be present the traps were usually kept under continuous surveillance. Nine captures were made in leg-hold traps, five in #2 coil-spring traps, four in #3 jump-traps. Two juvenile otter, captured in #3 traps, suffered broken hind legs and eventually died. A third juvenile otter caught twice in a #3 jump-trap suffered only some swelling in the toes. Very little injury occurred to otter captured in #2 traps. The disadvantage of leg-hold traps this size is that otter frequently escaped by pulling out. We experienced at least 35 escapes from #2 coil-spring traps.

Advantages: Small, light, easily transported, and can be set in a wide variety of locations.

Disadvantages: Non-target species may be caught and seriously injured. There is always the risk of serious injury to trapped otter, especially since they often violently fight the trap.

#### Foot Snare

One Aldrich foot snare was used on this study for a short period of time. It was sprung once by an otter that escaped. The potential for this capture technique is not really known.

Advantages: Like leg-hold traps, foot snares are small and can be set in places where larger traps cannot be placed. They are easily transported to less accessible areas.

Disadvantages: Non-target species may be caught and seriously injured. There is also the possibility of injury to a captured otter. Injury may be reduced if snares and leg-hold traps are used in conjunction with a spring pole. Further experimentation in this area is necessary.

#### Tomahawk Trap

Large two-door Tomahawk traps measuring 107 cm x 41 cm x 38 cm have been tested only recently. Thus far, one capture has been made, when a trap was placed over the entrance to a cavity in to which one of our instrumented otter had retreated. Two captures of juvenile otter approximately 3.6 kg each were made in small single-door Tomahawk traps measuring 51 cm x 20 cm x 20 cm. These traps, baited with fish, had been set for mink (*Mustela vison*).

Advantages: The large Tomahawk trap may be effective when placed in runways or tunnels leading to dens. Non-target species can be released unharmed. This trap can still be used during freezing weather.

Disadvantages: The trap is large and bulky, but light. It can be used only in certain places. Because it is easily sprung, non-target species can become a nuisance. The trap may not be strong enough to hold a large otter for any length of time.

### Culvert Trap

Four traps were made using 1.2 m sections of 30 cm diameter aluminum culvert in 1977. Spring-loaded doors were placed at each end. The trigger mechanism was similar to the kind used on conibear traps. These traps, though not extensively used, resulted in the capture of a yearling male otter.

Advantages: Trap can be set in shallow, running water without being sprung by the current. Small animals, such as muskrats (*Ondatra zibethica*) can pass through without springing the trap.

Disadvantages: The trap is large and bulky, but light. Otter were often reluctant to enter, choosing, instead, to go around the trap. Because of its size, the trap can only be used in certain locations.

### Barrel Trap

These traps were designed by personnel of the Idaho Cooperative Wildlife Research Unit for use on wolverine (*Gulo gulo*). They were made from barrel drums 91 cm and 74 cm long, with a diameter of 46 cm. A sliding door is triggered when the animal pulls on the bait suspended at the back of the trap. These traps were used extensively during the fall, winter, and spring of 1977-1978. Two captures were made in the barrel traps. Both otter were juveniles which had previously been trapped in Hancock traps.

Advantages: Barrel traps can be set at any time of the year, under any conditions.

Disadvantages: Traps are heavy and bulky. Most otter, especially older animals, are reluctant to enter them. The barrels proved to be far more effective on mink.

### Hancock Trap

The Hancock livetrap, originally designed for beaver (*Castor fiber*), is perhaps the most effective trap for capturing river otter. Since June 1977, Hancock livetrap have been the primary capture device used on otter for this study, with 21 captures resulting. Two adult-sized otter have been captured, simultaneously, in one Hancock trap. On one occasion, three juvenile otter weighing approximately 5 kg each were caught in one trap.

Several modifications are necessary to prevent the escape of otter from Hancock live traps (Fig. 1). Northcott and Slade (1976) describe two of these modifications, including the addition of a coil spring to the latches, and either wire or rope woven along the sides of the basket. The addition of a coil spring to each latch is not completely necessary if the trap is set as shown, because gravity will keep the latches in a locked position. When springs are not used, care must be taken to insure free movement of the latches at all times.

We have made two additional modifications, designed to prevent small



otter escaping. Each wire junction along the top of the back side is welded. The wire at the bottom of the back side is secured to an aluminum rod when the trap is constructed. Because wire cannot be welded to aluminum, we inserted a metal rod alongside of the aluminum rod and welded the wire to it. Both of these modifications prevent an otter from spreading the wire and escaping. On Vancouver Island an otter estimated to weigh about 12-13 kg, escaped by forcing its way between points A and B (Fig. 1) as the unmodified trap was lifted from the water. The placement of a metal rod welded to the wire, not only prevents wire spreading, but also adds support that might have prevented the otter from escaping. Finally, the traps are painted a flat brown to cover up the aluminum.

**Advantages:** Hancock traps may be set either entirely on land or with the basket side under water in places where otter climb out on land. Small, non-target animals are generally too light to spring the traps. When captured, they can usually be released unharmed. When traps are properly modified and set, escapes are fairly uncommon. Otter can be conveniently drugged in the trap.

**Disadvantages:** Size and weight limit the places where these traps may be set. They are largely inoperable during winter and other periods when frozen ground and snow cover prevail. Beaver may become a nuisance by frequently getting caught in the traps; we have caught 32 beaver in Hancock traps. On several occasions, beaver were in the traps when otter arrived at the site, thus precluding their capture. Otter may be injured if they are caught between the sides of the closing trap.

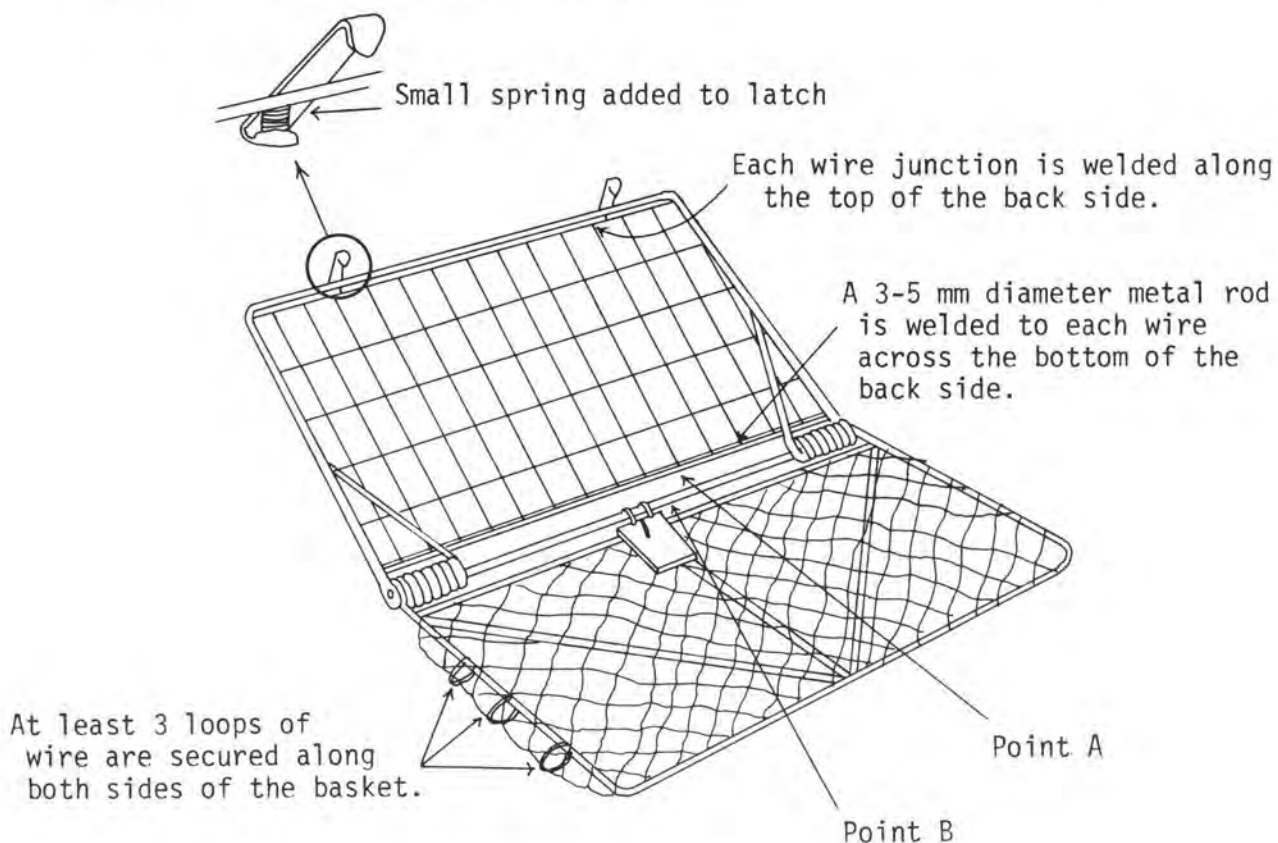

Figure 1. Modifications made to Hancock livetraps.



## Floating Trap

This trap may have great potential at fish hatcheries and areas where fish traps are operating. Fish depredation by otter at these facilities can create a major problem. In British Columbia, a floating trap was effectively used at a fish trapping facility to catch and remove problem otter (Stenson, pers. comm.).

The exact dimensions of this trap may vary, but the one which we constructed is 122 cm x 91 cm x 91 cm (Fig. 2). The frame was built of wood and aluminum to keep it light. Covered with chain-link fence material, the upper third of the trap front, where the animal enters, is left open. If small live fish are used for bait, chicken wire should be attached below the water line to prevent escape. The trigger mechanism includes a hinged frame in which chicken wire is loosely attached. The chicken wire has to be loosely attached. The chicken wire has to be loose enough to ensure that the otter is completely inside before the trap springs. A small rope attached to each corner of the hinged trigger frame extends up to pulleys on each side and continues toward the middle of the trap, where it then leads to the door. At the end of the rope a cotter pin passes through a hole in the frame and holds the plywood door open. The trap springs when an otter pushes down on either the hinged trigger frame or wire mesh, thus pulling the cotter pin from under the door.

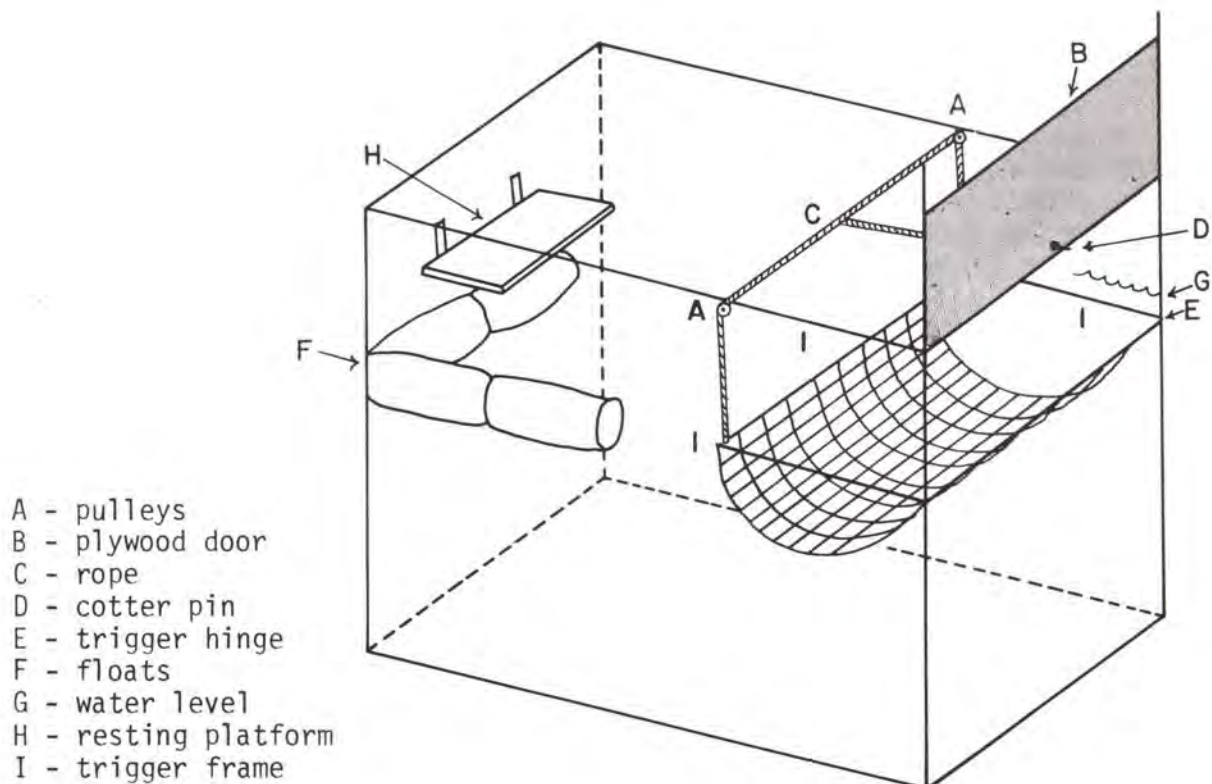

Figure 2. Floating trap designed for river otter.

Floats are placed around the trap, allowing slight submersion of the bottom of the entrance and trigger. Trapped animals may rest on a platform attached to the back of the trap, above the water line.

Advantages: This trap may be used in areas where conditions do not permit use of other traps -- frequently fluctuating water levels, rocky shorelines, and freezing conditions that still permit areas of open water.

Disadvantages: Perhaps the greatest disadvantage is trap size. It would be difficult to transport this trap to areas inaccessible by vehicle. Additionally, live fish must be available as bait.

### CARE AND HANDLING

Proper handling of otter is just as important as are effective capture techniques. Minimizing the stress experienced during capture and avoiding additional trauma and stress are important.

#### Drugging

Animals caught in leg-hold traps and Hancock livetraps are drugged with an intramuscular injection of ketamine hydrochloride at the capture site, placed in a transfer cage, and delivered to the holding pen. At the holding pen, they are provided a dark, quiet place for recovery. External stimuli should be minimized during recovery (also see Bigler and Hoff 1974; Ramsden et al. 1976). Animals captured in barrel, Tomahawk, and culvert traps are transferred in the trap to the holding pen without drugging.

We used ketamine hydrochloride as a drugging agent because it is easily administered by syringe, takes effect rapidly, and has a wide margin of safety. Ramsden et al. (1976) listed some of the advantages of this agent, including the fact that its effects are not cumulative as in barbiturates, so doses can frequently be repeated.

We administer the drug to otter, marten (*Martes americana*), mink, and beaver at a level of 22 mg/kg (10 mg/lb). Ramsden et al. (1976) describe different dosages for simple immobilization and a surgical plane of anesthesia. We have found the above dosage convenient when the animal is to be measured, tagged, weighed, and inspected, as well as when surgery is to be performed.

#### Handling

Our holding pen consists of an indoor section (2.2 m x 1.42 m x 2.0 m) connected by a 20 cm diameter culvert to an outdoor section (2.8 m x 2.0 m x 1.5 m). Animals may be allowed total use of the pen or confined to one section or the other by closing doors at either end of the culvert. This flexibility allows separate retention of animals if desired.

The 97 cm x 41 cm drugging box also serves as a nest box. The back, one side, bottom, and front are composed of wood (Fig. 3). The entrance,



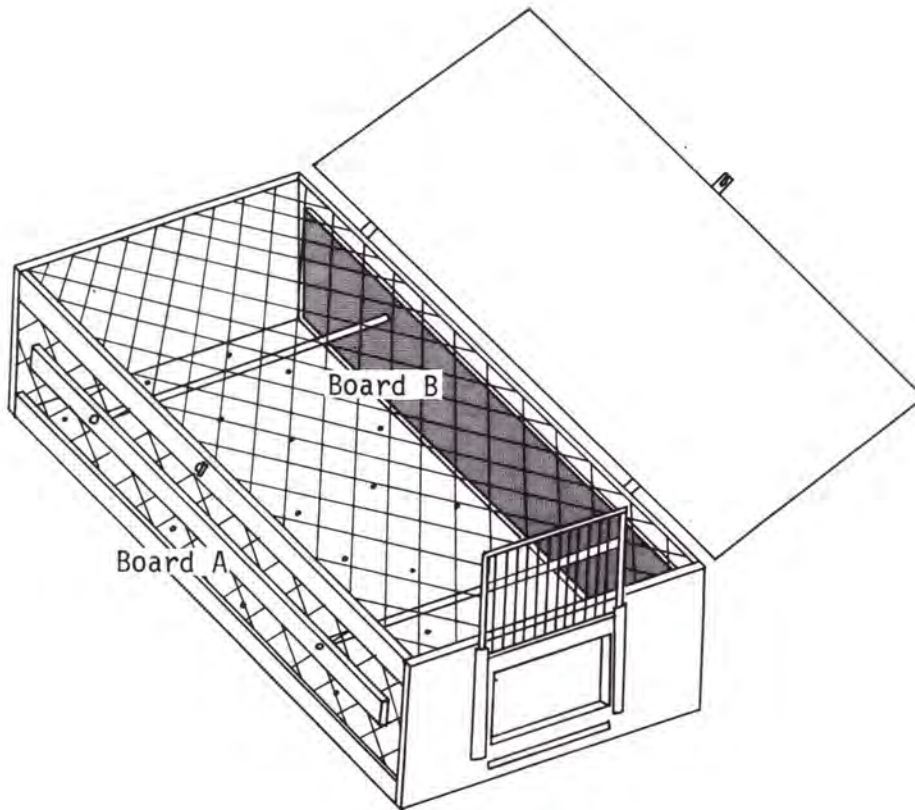

Figure 3. Drugging box for river otter.

at the front, has a sliding door. One side and the top are made of chain-link fence material. Also covering the top is a hinged plywood door that allows inspection of the contained animal. One side is wire so that the animal can be drugged when board A (Fig. 3) is pulled away from the box, thus compressing the animal against the wire and board B.

Otter have been held in these facilities for up to 65 days without any problems. Food, consisting mostly of fish, and water are provided to the animals daily. All otter kept for any length of time gained weight and looked healthy. Stenson (pers. comm.) has fed captive otter only fish and a vitamin supplement for well over a year without any apparent complications. Captured otter scheduled to receive a radio implant will usually be held for a minimum of 14 days.

When first released into the holding pen, otter are very frightened and seek shelter in a dark place. They usually do not eat during the first day in captivity. Each day they appear to become more and more accustomed to the surroundings. Otter, depending on the individual, will often take food from your hand and be active in your presence within just a few days. Too much contact with an animal could be detrimental, causing it to lose its fear of man and become more vulnerable when released.

## TELEMETRY

Radiotelemetry has allowed researchers an opportunity to collect data once impossible to obtain. For some time, radiotelemetry was limited to species with physical and behavioral features compatible to the present "state of the art". As package size decreased and range increased, telemetry became a feasible research tool for a greater number of species. Perhaps the most recent group of animals in which the use of telemetry became practical were those such as the otter, which are aquatic, semi-aquatic, or had physical features prohibiting the use of external transmitter packages.

### Collars

We began using external collars in 1976. From September 1976 until November 1977, 15 otter were instrumented. Collars were placed on juvenile, subadult, and adult males and females. The neck circumference of juveniles is smaller than the head, permitting the use of collars with moderate success. Subadults and adults have larger necks and thus present a problem. Several different collar designs were tested, including (in order) solid, expandable, and solid-lined-with-velcro for adults and expandable-with-velcro for juveniles.

Solid, smooth collars were kept on juveniles for more than 100 days before being slipped off. Although placed tightly on adults, smooth collars were readily removed by the animal. Smooth, expandable collars were slipped within a short period of time. Expandable collars incorporating velcro were retained with moderate success, but caused irritation. Solid collars lined with velcro were retained but caused neck irritation.

All of the otter appeared to accept the radio collar, although they frequently rubbed it against other objects. When an instrumented otter was part of a social group, unmarked members occasionally investigated the collar, but not excessively.

### Implants

Based on the continuous problems experienced with collars (either irritating the otter, slipping off, poor range, and /or radio failure), we decided to investigate the possibilities of implantable radio transmitters. Most of the work with radio implants involved small packages designed to collect physiological data on penned animals. Both subcutaneous and intraperitoneal implants had been successfully tested on other species. For otter, a subcutaneous implant was out of the question. We needed a package strong enough to give good range with a minimum life of 1 year. A transmitter fulfilling these requirements would be much too large to implant under the skin. Smith and Whitney (1977) suggested the feasibility of intraperitoneal transmitter implants for semi-aquatic mammals such as muskrat, beaver and otter.

Our first intraperitoneal implant was performed on a juvenile male otter on 17 December 1977 by Dr. G. Dale Smith, D.V.M. During 1978, radios



were implanted in nine additional otter. Initially, the incision was made ventrally, along the linea alba. Otter frequently rub and slide on their ventral surface. In two otter, we felt this rubbing, combined with the transmitter lying against the incision, caused breakage of the sutures. Consequently, we have made lateral incisions on the last five otter.

Nine of the ten transmitters implanted thus far weighed approximately 130 g each. They are somewhat cylindrical in shape with a length of 10.5 cm and a diameter of 4.1 cm. Estimated life of these implants is 12-14 months. Our best ground-to-ground range has been approximately 3.5 km. Range varies depending on the animal's activity and location, and is greatly increased from an airplane.

Recently a smaller implant, weighing 65 g with a length of 6.5 cm and a diameter of 2.8 cm, was surgically implanted in an otter. The estimated life of this transmitter is 17 months. Preliminary testing indicates that the range of the smaller transmitter is less than that of the larger ones. However, considering that it is less expensive, smaller, and has a longer life expectancy, its performance appears acceptable. Smaller transmitter implants are preferred for females likely will become pregnant.

The weights of otter implanted ranged from 4.08 kg to 8.62 kg. Transmitter weights ranged from 1.3% to 3.2% of the animal's weight. The smallest otter implanted was shot by a hunter 68 days after surgery. An inspection of the intraperitoneal cavity revealed no abnormalities or rejection of the implant. Our observations indicate that the wax-coated radio implants are biocompatible and do not inhibit otter in any way.

#### IMPLANT PROCEDURES

Based upon previous experience, we feel the following procedures should be employed in (1) preparing the transmitter for implant, (2) preparing the animal for surgery, (3) the actual surgery, and (4) post-operative care of the animal.

1. The animal is not fed for at least 12 hours prior to surgery.
2. Approximately 1 hour prior to surgery, the transmitter is washed in surgical soap and placed in benzalkonium chloride for sterilization.
3. The animal is drugged with an intramuscular injection of ketamine hydrochloride (10 mg/lb or 22 mg/kg).
4. A portion of the skin is then shaved clean where the incision will be made. Enough area should be shaved to provide approximately 1.0 cm of bare skin on all sides of the incision. The actual incision site is on a dorso-ventral axis, anterior to the

hind leg, posterior to the ribs, and slightly below the dorsal surface of the animal.

5. The animal is then transferred to the operating table where the incision site is washed with organic iodine. After placing a drape over the animal, it is ready for surgery.
6. Using a scalpel, an incision is made through the skin, just large enough to allow insertion of the radio. The underlying muscles are torn open, rather than cut, by separating the muscle fibers along the main axis of each muscle layer. Care must be taken not to injure a kidney, the diaphragm, or other internal organs.  
NOTE: Surgery is performed under as steril conditions as possible in an effort to reduce the possibility of infection.
7. The radio is then inserted into the intraperitoneal cavity and allowed to "float free".
8. Each tissue layer is sutured using biodegradable gut suture material. Monofilament teflon suture material for strength is used for final suturing of the skin.
9. After the operation, the animal is given an injection of antibiotics and then placed in a quiet, dark area for recovery.
10. The animal is given water, but not fed for at least 12 hours after surgery.
11. To minimize the possibility of a rupture due to excessive movement, the animal is confined in a small holding pen (approximately 100 cm x 45 cm x 30 cm) for about 7 days, especially at night. This time period may vary, depending on how active the animal is and how well the incision heals.
12. After about 7 days, the animal is drugged, weighed, and thoroughly inspected. If normal healing is apparent and there is no sign of a rupture (bulging appearance), the animal is then released into a large pen. The animal is allowed free movement within the large pen for an additional 2 or more days, after which time it is observed for possible rupturing of the muscle or tearing of the skin. If neither has occurred, and the animal appears healthy and is feeding properly, it is then released. The sutures in the skin may be removed prior to releasing the animal, but this is not necessary.



## POPULATION STRUCTURE

Otter populations are composed of breeding adults, nonbreeding adults, subadults, and juveniles (Table 1). Depending on the time of year, any one of these individuals may be found alone, or in association. To facilitate interpretation of otter sign, we listed possible group compositions for different periods of the year. To accommodate the wide variety of climates in which river otter are found, we then divided the year into breeding and nonbreeding periods. The breeding period extends from the time when an adult female comes into estrus, until she first leaves the natal den with her pups. The nonbreeding period would be the remainder of the year.

With the exception of the Class A association, all other classes may occur during the nonbreeding period. The presence of Class H through N associations (except Classes K and L) generally would not occur until approximately 3 months after the pups are weaned. Family groups may start to break up at this time. Although we have observed Class K and N associations, they are probably uncommon.

Adult male otter tend to be solitary, except during the breeding season when they accompany estrus females. On one occasion, during the fall, we observed what was believed to have been an adult male otter with a female and her two pups. He was only seen with this family group on this one occasion. Nonbreeding adults and subadults of either sex (Classes D, E, F, G, and L) may also be present in the area during the breeding period.

## CENSUS TECHNIQUES

Numerous techniques have been developed for censusing a variety of animals (Fitzner et al. 1977). Considering a certain margin of error, these techniques may provide data on population trends, relative abundance, density, species diversity, biomass estimates, movements, and perhaps more. Because of their habits, reliable census techniques for certain species, including river otter, are difficult to develop.

We have concluded that there is no simple method of censusing river otter. The presence of otter in an area can easily be determined by searching for tracks, scats, and other sign. Population estimates are obtained through a combination of capture data, visual observations of unmarked otter, tracks and other sign.

### Capture Data

Captured otter are ear-tagged with small metal fingerling tags. Color-coded tags could be used to identify individuals in the field, especially when radio-telemetry techniques are not employed. These tags are readily seen through binoculars and enable the observer to distinguish between marked and unmarked animals.

Table 1. Possible solitary and group associations in which otter may occur during breeding and nonbreeding periods.

Period of occurrence		Class	Composition
Breeding	Nonbreeding		
X		A	Breeding adult male and female
X	X	B	Adult female and her pup(s)
	X	C	Adult male, female, and her pup(s)
X	X	D	Adult male
X	X	E	Adult female
X	X	F	Subadult male
X	X	G	Subadult female
	X	H	Juvenile male
	X	I	Juvenile female
	X	J	Adult female, her pup(s), and one or more unrelated pups
	X	K	Adult female, her pup(s), and one or more unrelated subadults
X	X	L	Two or more subadults of either sex; related or unrelated
	X	M	Two or more juveniles of either sex; related or unrelated
	X	N	Subadult(s) and juvenile(s) or either sex; related or unrelated



## Visual Observations

Although otter may be active at any time during the day or night, visual sightings are most often made during crepuscular hours. Otter often spend a great deal of time in areas where food is seasonally abundant or concentrated (e.g., spawning grounds). These areas are ideal for making visual observations. Sightings of unmarked otter in areas where marked animals occur provide additional information about the otter population in a given area. Unfortunately, because visual sightings of otter may be few and far between, they alone would not be reliable for determining population density.

## Tracks, Scats, and Other Sign

Areas where otter emerge from the water are called "pulling out" places (Liers 1951) or "landings". In addition to footprints, Grinnell et al. (1937) describe at least four other important kinds of sign that may be left by otter. These include slides, rolling places, sign heaps, and droppings (feces or scats). With the exception of slides, these sign types may be found at otter landings.

The presence of otter slides is most likely exaggerated. We have yet to see a place where otter have repeatedly slid, either through the snow or in the mud. This does not mean that otter do not slide. By alternately loping and sliding through the snow, otter are able to rapidly cover great distances. In 1976, we observed where a family group had slid continuously through the snow for about 300 m down the side of a mountain.

Rolling places usually occur in grassy or sandy areas along stream banks and prominent points of land along ponds, lakes, and other large bodies of water. Vegetation at grassy sites may be conspicuously matted down for 1-3 m across. Rolling places occur where otter dry off, groom, rub themselves, or indulge in social interactions such as care-giving behavior. At these sites, otter may build sign heaps by twisting the grass or scraping it into small mounds where scent is then deposited from their anal glands. In addition, otter will often defecate at rolling places before departing from the area.

Otter frequently defecate on logs that project out into the water, on logjams, sandbars, rocks, or any object that sticks out of the water. In the winter, sign may be covered by frequent snowfalls. Furthermore, otter will occasionally tunnel into the snow and defecate, making discovery difficult. Because of the snow cover, most traditional landings are not used in the winter.

The number of scats in a specific area is not always a good indication of how many otter are present. A single otter may defecate several times in one place in a matter of hours. We followed the tracks of two otter traveling upstream on Lake Fork Creek just after a snowfall in April 1977. These two otter defecated at least eight times in a 2.4 km distance.

Presence of tracks can provide useful information when attempting to determine the population density and composition of otter in a selected area. Preferably, there should be sandbars, mudflats, and areas of exposed soil where tracks would be visible. The value of this information depends on how well tracks show up in the substrate. Areas where the substrate is dominated by rocks and gravel would reveal few tracks. Winter surveys, when snow covers the ground, would be more desirable in these areas.

The absence of tracks in an area searched may not necessarily indicate that it is not occupied by otter. We have often failed to find fresh sign in consistently used areas even when our instrumented otter are in the vicinity. Conversely, one otter can leave an abundance of tracks and other sign when occupying a small area.

In west-central Idaho, tracks indicate that juvenile otter probably start traveling with the female in late June. At this time, it is easy to distinguish the tracks of juveniles from older otter. This becomes progressively difficult as the pups continue to grow. By October, tracks of juvenile otter are nearly the same size as those of older animals; delineating one from the other with any degree of confidence is almost impossible.

#### RECOMMENDATIONS

The following suggestions are offered to biologists who are faced with the task of censusing an area for otter.

Otter often travel to mountain lakes, up feeder creeks, to ponds and reservoirs, or concentrate in a small section of their home range. Consequently, they may be absent from a substantial portion of their range for extensive periods. Because of this, as much of the area in question as possible should be checked for sign. This is especially important when searching for fresh activity. If this is not feasible, selected sites should be periodically checked in an effort to detect otter that move into, or through, these areas.

Otter population densities vary throughout the country. Prey abundance, weather conditions, human activities, competitive interactions, and den site availability influence the total number of otter inhabiting a specific area. Population structure, as well as density, probably will vary in areas where otter trapping is permitted. Based on our studies of approximately 60 straightline kilometers of rivers and lakes (12% lakes) in west-central Idaho, the following data may be used as a general basis for estimating the density and structure of otter populations. These figures were arrived at by dividing the total estimated population into the size of the study area.

We estimate there is approximately one otter for every 2-3 km of waterway. This is straightline distance; the actual distance in a meandering straightline distance; the actual distance in a meandering stream might be



a great deal more. Tributaries are not included in this measurement, although they may be part of the animals' range.

Based on social structure, there would be one family group (adult female plus two or three pups) and one to three subadults and/or nonbreeding adults for every 15 km of waterway. In addition, at least one breeding adult male would occupy approximately 20-30 km. This does not mean that only one family group would occupy a specific 15 km of waterway. We have found more than one family group plus subadult otter occupying an area where salmon were spawning. Simultaneously, otter were absent from large sections of the study area.

### CONCLUSIONS

Research techniques for river otter have only recently been developed. Technical advancement in radiotelemetry and an increased interest in the species have made it feasible to conduct field research on certain aspects of otter ecology that were once not possible. As a result, several research projects on river otter have recently been initiated. The need for reliable research techniques has thus become apparent in an effort to reduce time and cost of such projects. As we progress in our knowledge of the otter, these techniques will no doubt be modified and new ones added.

#### LITERATURE CITED

- Bigler, W. J., and G. L. Hoff. 1974. Anesthesia of raccoons with ketamine hydrochloride. *J. Wildl. Manage.* 38:364-366.
- Eveland, T. E. 1978. The status, distribution and identification of suitable habitat of river otters in Pennsylvania. Unpubl. M.S. Thesis. East Stroudsburg State College, Pennsylvania. 54 p.
- Fitzner, R. E., L. E. Rogers, and D. W. Uresk. 1977. Techniques useful for determining raptor prey-species abundance. *Raptor Res.* 11(3):67-71.
- Grinnell, J., J. S. Dixon, and J. M. Linsdale. 1937. *Furbearing mammals of California*. Vol. 1. Univ. Calif. Press, Berkeley. 375 p.
- Harger, E. M. 1961. Panned studies on river otter. Michigan Project W-70-R-11. Unpubl. 4 p.
- Liers, E. E. 1951. Notes on the river otter (*Lutra canadensis*). *J. Mammal.* 32(1):1-9.
- Northcott, T. H., and D. Slade. 1976. A livetrapping technique for river otters. *J. Wildl. Manage.* 40(1):163-164.
- Ramsden, R. O., P. F. Coppin, and D. H. Johnston. 1976. Clinical observations on the use of ketamine hydrochloride in wild carnivores. *J. Wildl. Diseases* 12:221-225.
- Smith, H. R., and G. D. Whitney. 1977. Intraperitoneal transmitter implants--their biological feasibility for studying small mammals. Pages 109-117 in F. M. Long (ed.). *First International Conference on Wildlife Biotelemetry*. International Conf. on Wildl. Biotelemetry, Laramie, Wyoming.