



University of Idaho
College of Agriculture

Cooperative Extension Service
Agricultural Experiment Station

LIBRARY

FEB 26 1981

UNIVERSITY OF IDAHO
Current Information Series No. 520

Reprinted September 1980



Installation of Wood Stoves in Fireplaces

Thomas J. Karsky, Extension Farm Safety Specialist

Fireplaces are inefficient wood heaters. They use 4 to 10 times as much wood to generate the same amount of heat as a modern airtight stove. Most of the heat generated in a fireplace goes directly up the chimney. There are many ways to improve the efficiency of a fireplace (see University of Idaho Current Information Series No. 494, *Fireplace Adapters and Efficiency Boosters*). Adding a stove to a fireplace is perhaps the best way to get the most heat output.

Installing a stove in or in front of a fireplace and using the chimney can save the trouble and expense of installing a new chimney. Before you consider adding a stove to an existing fireplace chimney, first check the chimney to make sure it is sound and suitable for a wood stove. If your chimney does not have a flue liner, or if the flue is too large for the stove, consider installing a stove pipe inside the fireplace chimney. An oversized chimney can cause excessive cooling of the flue gases because of its large surface area. This cooling can result in low flue gas velocity, condensation, creosote buildup and low draft. Adding a smaller flue or liner can correct these problems. For information on chimneys and on installing a stove pipe liner in a chimney, see CIS No. 479, *Chimneys*.

Stoves can be added to a fireplace in several ways. Free-standing stoves can be installed so that the stove pipe enters into the fireplace chimney above the damper, through the damper or into the firebox below the damper. Properly designed stoves can also be inserted into the fireplace opening.

Stove Pipe Entering the Fireplace Chimney Above the Damper

Fig. 1 shows a stove installation with the stove pipe entering the chimney at a point above the fireplace damper. This installation requires cutting a hole through the masonry above the fireplace throat. CIS No. 479, *Chimneys*, discusses how to install the stove pipe to the masonry chimney wall. Make sure that the damper is tightly sealed or provide a seal so that gases do not enter the room through the fireplace. This can be done with sheet steel or fibrous insulation, such as rock wool. This type of installation may result in higher energy efficiency and better draft than installing the stove pipe through the damper or just into the firebox. This installation can be easier to inspect for creosote and easier to clean than the others.

Stove Pipe Entering the Fireplace Chimney Through the Damper

A stove can be installed so that the stove pipe enters the fireplace chimney through the fireplace damper, with the damper either opened or removed (Fig. 2). This installation often can be made without additional masonry work. If your fireplace chimney does not have a liner, you should run the stove pipe up to the top of the chimney and seal the area between the liner and the chimney wall at the top and at the bottom near the damper. Because of chimney design, some fireplaces may have to be altered to make a connection so that the stove pipe goes straight up the chimney.

3

322

520

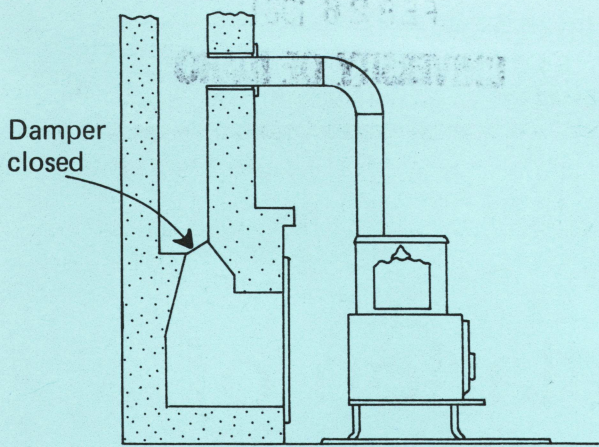

Fig. 1. Stove pipe entering chimney above the fireplace damper.

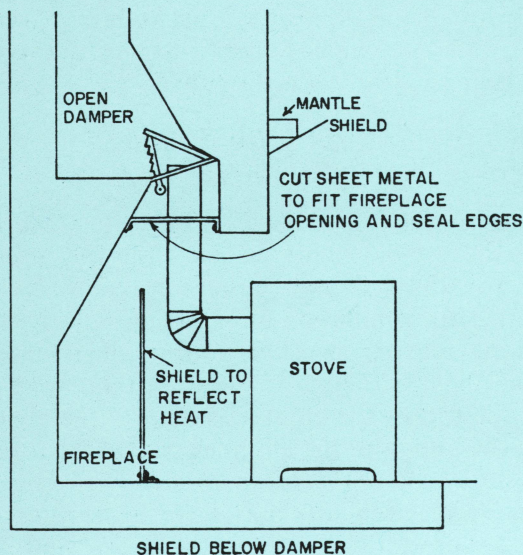
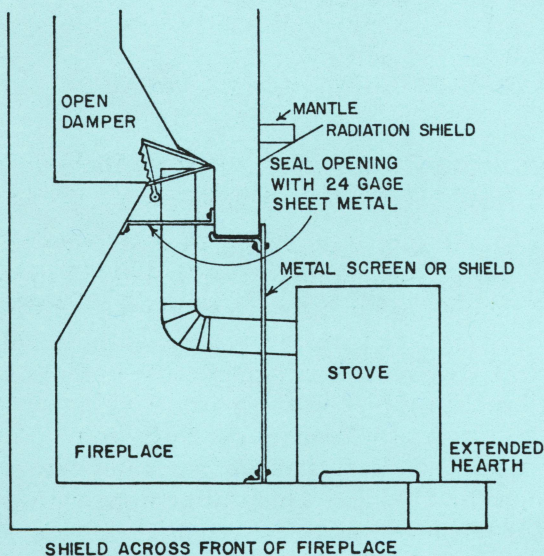

Fig. 2. Stove pipe entering chimney through damper.

Since masonry tends to absorb heat produced by the stove, you should place a reflective metal shield between the stove and the inside masonry to reflect the heat back into the room. This shield can be located either in the firebox or at the fireplace opening. Seal off the chimney with sheet steel or fibrous insulation (rock wool, fiberglass).

Stove Pipe Entering into the Firebox

Installing the stove with the stove pipe entering the fireplace box is the easiest installation (Fig. 3). This can be done by placing a shield of metal or asbestos millboard across the fireplace opening and cutting a hole to insert the stove pipe. **This type of installation is the least satisfactory and is potentially dangerous because the cooler environment in the fireplace opening can result in more creosote accumulation and less draft.** If slow burning fires prevail, liquid creosote may flow out beneath the cover panel into the house. Shelton (1) reports solid creosote building up 2 or 3 inches thick inside the fireplace. If this were to ignite, a serious fire could result. By extending the pipe into the damper you can reduce the creosote and draft problem.

Additional Installation Considerations

Because the wood stove needs floor protection, the hearth may need to be extended. Proper clearance from combustibles are also needed. Wood mantles and trim may need protection. For these and other installation requirements, see CIS No. 485, Wood Stove Installation and Safety.

When installing a stove to a prefabricated metal fireplace, make sure the chimney is the insulated or solid pack type. Stoves should not be added to prefabricated fireplaces with thermo-siphon type chimneys (triple wall chimneys which

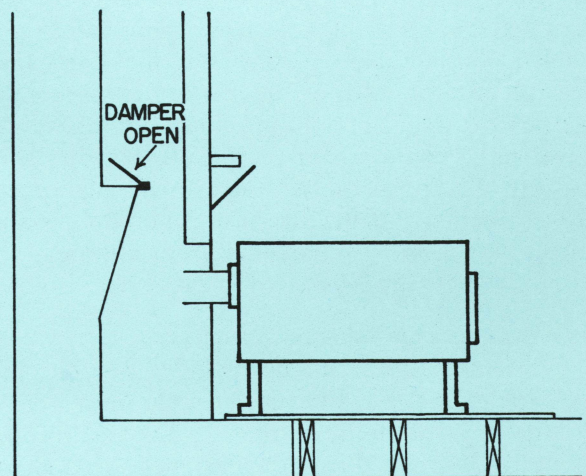

Fig. 3. Stove pipe entering the fireplace opening.

allow air movement to cool down the interior wall). Since airtight stoves have cooler exhaust gases than fireplaces, this air movement may cool the interior surface too much and cause creosote formation.

Fireplace Stove Inserts

Many stoves are designed to be placed directly into the fireplace opening (Fig. 4). The installation can be simple or may require some work depending on the stoves. Make sure that this type of stove has a good connection to the chimney flue. Otherwise creosote may build up. If the flue does not have a flue lining, consider installing a pipe in the chimney if possible. Since the exhaust gases of stoves are cooler than those of fireplaces and since the flue may be larger than required by the stove, creosote will tend to form. Install the insert so that it can be removed readily for chimney cleaning. Inserts should not be installed in fireplaces with thermosiphon chimneys because of the cooling effect mentioned earlier.

Using fireplace inserts in zero-clearance fireplaces is not an approved installation. Zero-clearance fireplaces are approved as a fireplace unit but have not been sufficiently tested to be approved for use with another appliance. One problem is that inserts concentrate the heat within the fireplace. Air movement in the zero-clearance fireplace may not

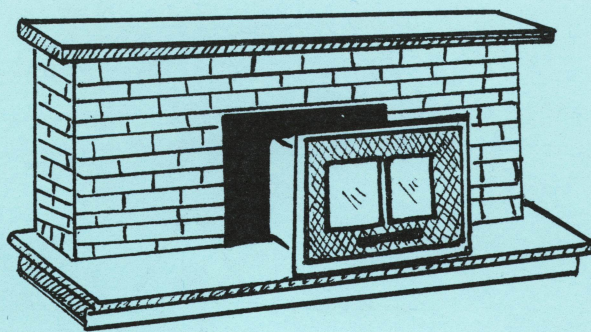

Fig. 4. Fireplace insert.

be sufficient to carry away the additional heat generated in the air jacket of the unit. This additional heat can present possible fire danger to a nearby wall. Another problem is that the cover plate over the fireplace opening may block openings for cooling air needed for circulation through the fireplace and chimney.

References

Wood Heat Safety, by J. W. Shelton, \$8.95. 1979. Garden Way Publications, Charlotte, VT 05445.

Link a Wood Stove to Your Fireplace, by Mary Twitchell, \$1.00. 1977. Garden Way Bulletin, A-12, Garden Way Publications, Charlotte, VT 05445.



SERVING THE STATE

Teaching . . . Research . . . Service . . . this is the three-fold charge of the College of Agriculture at your state Land-Grant institution, the University of Idaho. To fulfill this charge, the College extends its faculty and resources to all parts of the state.

Service . . . The Cooperative Extension Service has offices in 42 of Idaho's 44 counties under the leadership of men and women specially trained to work with agriculture, home economics and youth. The educational programs of these College of Agriculture faculty members are supported cooperatively by county, state and federal funding.

Research . . . Agricultural Research scientists are located at the campus in Moscow, at Research and Extension Centers near Aberdeen, Caldwell, Parma, Tetonian and Twin Falls and at the U. S. Sheep Experiment Station, Dubois and the USDA/ARS Soil and Water Laboratory at Kimberly. Their work includes research on every major agricultural program in Idaho and on economic activities that apply to the state as a whole.

Teaching . . . Centers of College of Agriculture teaching are the University classrooms and laboratories where agriculture students can earn bachelor of science degrees in any of 20 major fields, or work for master's and Ph.D. degrees in their specialties. And beyond these are the variety of workshops and training sessions developed throughout the state for adults and youth by College of Agriculture faculty.

Issued in furtherance of cooperative extension work in agriculture and home economics, Acts of May 8 and June 30, 1914, in cooperation with the U. S. Department of Agriculture, James L. Graves, Director of Cooperative Extension Service, University of Idaho, Moscow, Idaho 83843. We offer our programs and facilities to all people without regard to race, creed, color, sex or national origin.