

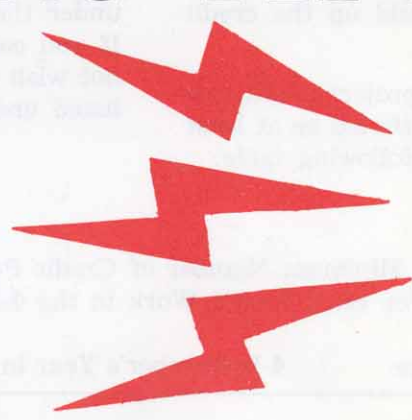

ELECTRICITY

for the 4-H scientist



Safety
Uses
Economy

DIVISION I
4-H ELECTRIC



UNIVERSITY OF IDAHO

College of Agriculture



GETTING ACQUAINTED WITH ELECTRICITY

Electricity serves you best when you understand how it works and use it properly. As a 4-H member, you should know about electricity and help to show others the way to obtain its tremendous work-saving benefits as well as how to use it with safety.

A good way to think of electricity is to compare it with water. It acts a lot like water. However, it is made of tiny parts of atoms called electrons. When there are more than the normal number of electrons in anything, it is said to be negatively charged; when there is a shortage of electrons, it is positively charged. As water flows downhill, "seeking its level," electrons flow from negative to positive, seeking to "balance" the charge.

Electrical Conductors

Even if you're never going to repair a lamp or make a chick brooder, you should know about conductors and insulators. This is because you happen to be a fairly good conductor of electricity. Electricity will pass easily through you to other conductors - the ground, for instance. When this happens you may get a shock, burn, or serious injury. But it doesn't ever have to happen, if you learn to understand your friend, electricity.

Silver, copper, iron, aluminum and many other metals are very good conductors. Water, acids, and salts are too. Electricity passes over or through them very easily. Like water pipes, the larger the conductor, the more electricity it can carry. When conductors are too small for the amount of electrons trying to move over them, they get hot, melt, may start fires. That's why wire size is important.

Electrical Insulators

Insulators are the opposite of conductors. Electricity has trouble passing through some materials. Rubber, most plastics, dry wood, oils and glass are some of the good insulators. It's the amount and kind of insulation that counts. If it has enough force, electricity can pass through just about anything - even jump gaps!

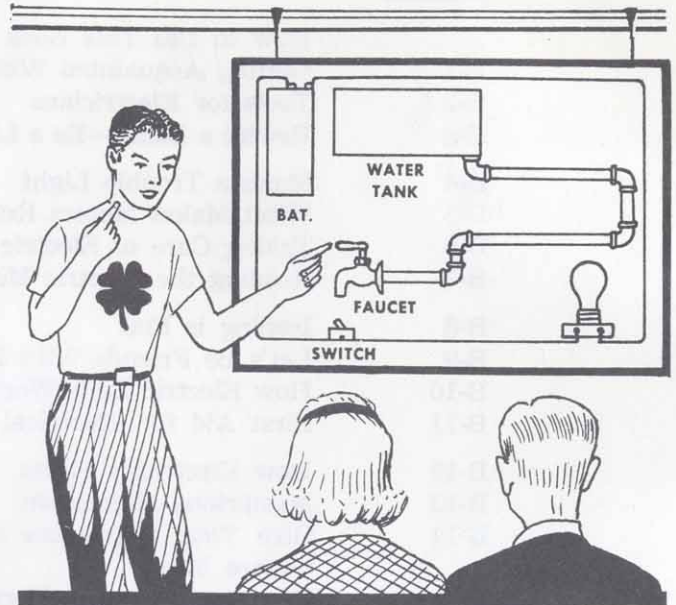

Electricity, like water, flows along the easiest paths. It is always trying to get to the ground. The earth attracts it. It stays on the wires unless a person, a wet branch, or some other conductor gives it a path to the ground. Do not touch any wire which might be carrying electricity.

Play It Safe

If you should touch a "hot" wire accidentally and are standing on a dry piece of wood, the conducting pathway to the ground is not good and the electricity may keep running along its wire. But do not touch some other conductor with another part of your body. This would complete a circuit through your body and would be very dangerous. Always make sure there is plenty of good insulation material or plenty of distance between you and anything which might be carrying electricity.

Remember, too, insulation is of little use when it is wet. Dew, mist, rain, condensation, a damp floor can change the whole picture. If you understand electricity and how it acts, you'll be safe enough, because you won't take chances or expose yourself to injury.

Electrical Terms

Alternating Current - Usually referred to as "AC," alternating current is current which reverses its direction of flow at regular intervals, 60 times a second.

Direct Current - "DC" current flows only in one direction. Battery current is DC.

Ampere - Amperes are units by which the rate of flow of electrical current (electrons) is measured. An ampere is 6.3 billion electrons passing one point in a circuit, in one second. This compares with the way the flow of water is measured in gallons per second.

Volts - A volt is a unit to measure the tendency of electrons to move when they are shoved. Voltage is the amount of "push" behind the electrons. It's like water pressure in a pipe. Home power lines carry 115 volts (110 to 120 volts). For appliances such as electric stoves, washers and driers, a second 115-volt line should be added, giving 230 volts (220 to 240 volts).

Watts - Watts equal volts times amperes. Light bulbs, electric irons and other appliances are usually marked with the voltage they require and the number of watts.

Kilowatts - Your electric bill usually reads in kilowatt hours. A kilowatt is 1000 watts. A kilowatt hour equals 1000 watts used for 1 hour. One kilowatt equals about 1-1/3 horsepower. A kilowatt is usually indicated by "kw" and a kilowatt hour by "kwh."

Circuits - A closed circuit is one in which the electricity is flowing, lighting a light, running a motor, or some other appliance. The circuit runs all the way from the place the electricity is being generated to your home, through the appliance or light bulb, and back to the generator.

Circuits are opened and closed by switches. When the circuit is opened, the electricity stops at the switch. Before working on a switch, socket, fuse, or any part of the wiring be sure to open the main switch. The main switch is usually at the fuse box or near it. Appliances should be disconnected when you work on them. Everyone in the family should know where the main switch is so it can be pulled in case of accidents, fire, flood, or windstorm damage.

Fuses and Circuit Breakers - These are the safety valves of your electrical system. The different electrical circuits in your home are meant to carry only certain amounts of electricity. Some carry only 15 amps, others can carry 20 or more. They are marked to show capacity.

When a fuse burns out or a circuit breaker opens, look for an overload of lights and appliances on the circuit before you try to replace the fuse or close the circuit breaker. Without these safeguards, the overloaded electric line will heat up and may start a fire. Even if no fire starts, electricity will be wasted and the homeowner will be paying for electricity that's doing no good.

Remember: If you ever have to replace a fuse, pull the main switch first. Keep a flashlight handy in your house. It seems that fuses usually blow at night, and it doesn't pay to stumble or fumble around electric wires in the dark.

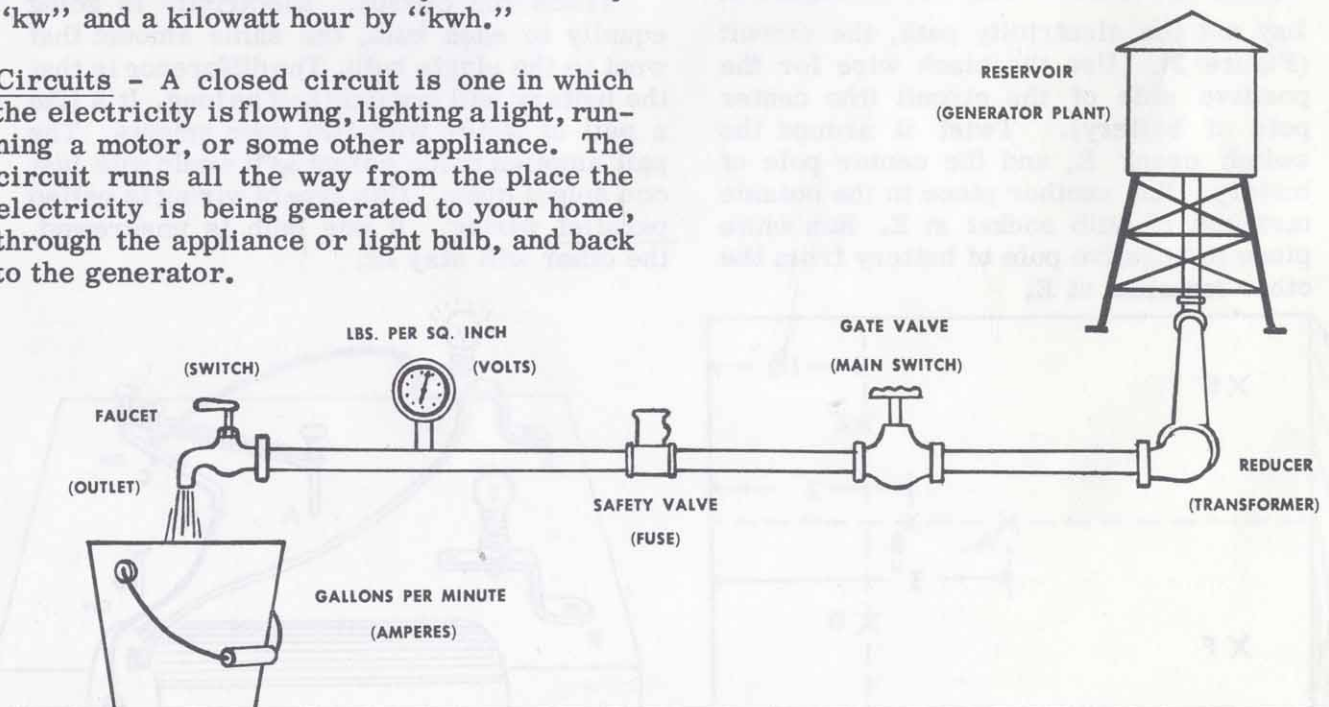

WHAT TO DO: Make A Circuit Board

So that you can show others how electricity travels from here to there, and how it behaves under different conditions, make an electric circuit board.

Materials Needed:

- Piece of $\frac{3}{4}$ " board about 4" x 6"
- 1- $\frac{1}{2}$ -volt No. 6 dry cell battery
- Two pieces of bell wire, each 24" long, one black, one white
- Two 10-penny box nails (3")
- Three 3-penny box nails (1")
- Two small screws or carpet tacks
- Two 2-inch rubber bands
- Two miniature sockets with solder terminals
- Two 1- $\frac{1}{2}$ -volt flashlight bulbs

Tools Needed:

Ruler, pencils, hammer, pliers or vise.

Making the Board:

1. Lay out the board with a pencil and ruler as indicated in Figure 1.
2. Bend the three-inch nail as shown in Figure 2, using pliers, vise and hammer.
3. Pound the one-inch nails into the board for a half-inch at points A, C, and D. Use the three-inch nail to make a hole a half-inch deep at B. Put the crank nail in this hole and pound in a little farther. Attach the lamp socket brackets at E and F. Stretch the rubber band as in Figure 3.
4. Lay out the electricity path, the circuit (Figure 3). Use the black wire for the positive side of the circuit (the center pole of battery). Twist it around the switch crank B, and the center pole of battery. Run another piece to the outside terminal of bulb socket at E. Run white piece to negative pole of battery from the other terminal at E.

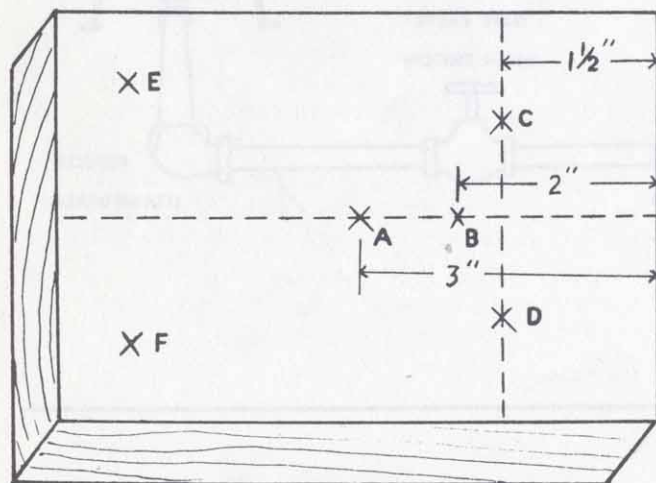

Figure 1 (Circuit Board)

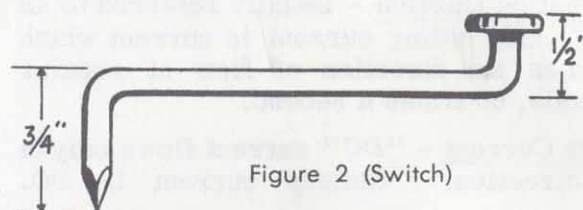

Figure 2 (Switch)

5. Close the switch. The rubber band should hold the switch nail tightly against nail at C. Does the bulb light? _____

If it doesn't, check the connections.

Now you have a circuit - a closed circuit when the electricity runs all the way from the positive pole to the negative pole. The black wire is the hot side, the live wire, because it carries the full load of the battery up to the bulb.

Remember, battery current is direct current, DC. In the case of alternating current, AC, such as most homes and buildings use, the electricity flows in first one direction and then the other.

Parallel Wiring

To make this circuit hookup, attach another white wire to the negative pole of battery and a terminal of the second flashlight bulb. Run a black wire from the other terminal to the switch terminal at C (Figure 4). Close switch. Both bulbs will light.

Trace the circuit. Electricity is going equally to each bulb, the same amount that went to the single bulb. The difference is that the battery will last only half as long. It's like a pail of water with two open spigots. The pail empties twice as fast as it would with just one spigot open. This type of wiring is called parallel wiring. If one bulb is unscrewed, the other will stay lit.

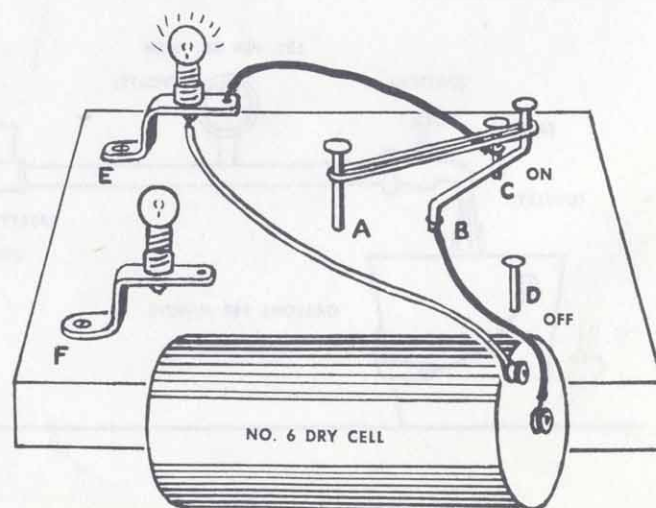
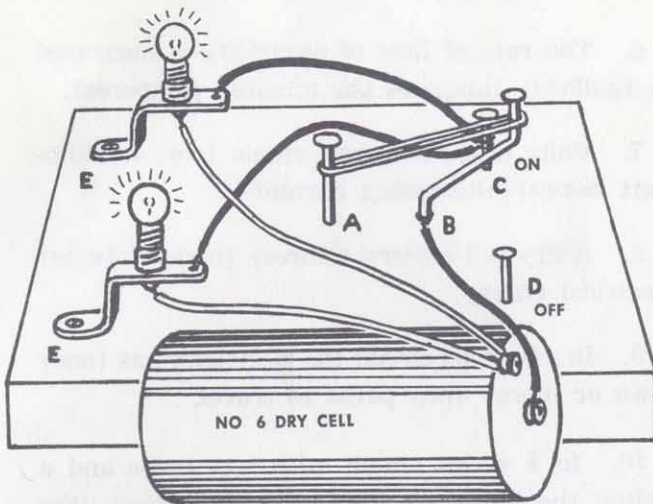

Figure 3 (Closed Circuit)

Figure 4 (Parallel Wiring)



Series Wiring

To do this, run the negative wire to one terminal of the second bulb and attach a wire from the other terminal to a terminal of the first bulb. The other terminal connects with the switch at C (Figure 5). This is series wiring. If one bulb is unscrewed, the other will fail to light because the circuit is broken for both. Anything that breaks the circuit has the effect of opening the switch.

Show there is a circuit through the bulb by screwing and unscrewing it. Also, "jump" the socket by running the wire from C to the other terminal of the bulb at E while it is unscrewed. Bulb at F will light. Trace this circuit.

Figure 5 (Series Wiring)

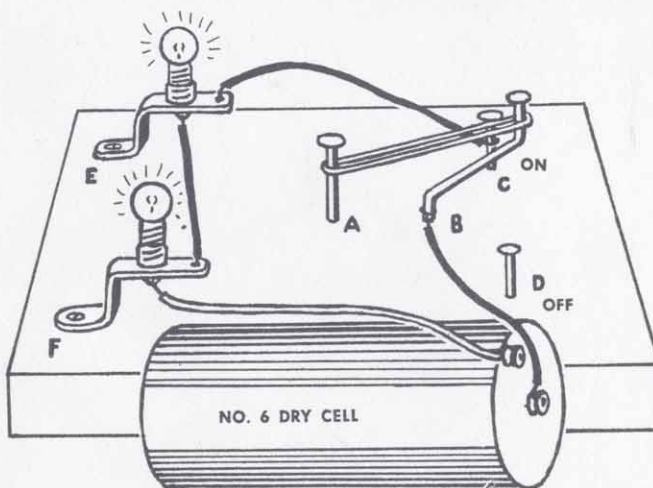

SUGGESTED DEMONSTRATIONS

Using the Circuit Board, you can give many demonstrations of the way electricity flows, works and behaves.

Water And Electricity

To help others understand electricity better, draw a water system on an electric circuit board paralleling the circuit. For the battery show a water tank, pipes instead of wires, faucets instead of switches. Somewhere on the board paste a comparison of electrical terms with terms used in describing water, such as the following:

Wire equals Pipe

Volts equal Pressure

Amperes equal Rate of Flow - gallons per second

Watts equal Pressure times Rate of Flow

Switch equals Faucet

Current equals Flowing Water

Show how to figure the wattage that a circuit protected by a 15 ampere fuse can handle. Do it with actual things or cut-out pictures of light bulbs, irons, toasters, coffee-makers, etc.

You know that Amperes times Volts equal Watts. If the voltage is 115, a 15 amp circuit can handle 115 volts times 15 amps, or 1725 watts.

The name plates on electric motors indicate the amperage at full load. You can convert this to watts, of course, by multiplying amperage by the line voltage. Motors require an additional amount of electricity when they start. You need to allow for this fact, so fuses will not blow or circuits trip when a motor is turned on. You will learn more about this when you study electric motors.

For More Information

Your leader has many other sources of information about electricity and demonstrations you can perform. Ask him. Also, libraries have many books about electricity and its history, which are very interesting and useful. Maybe you can find an electrician, someone from your power supplier, or an equipment dealer who will talk to your club on electricity or electrical safety.

What Did You Learn?

(Underline the correct answers then discuss in the group.)

1. In a water pipe system water flows. In an electrical circuit (electrons) (atoms) (charges) flow.
2. Electricity or electrons flow (easier) (harder) (about the same) in a conductor than in an insulator.
3. Rubber is a good (conductor) (insulator) (ground).
4. The most common material used as an electrical conductor is (glass) (silver) (copper).
5. The unit of electrical pressure or push is the (ampere) (volt) (watt).
6. The rate of flow of electricity is measured in (gallons) (amperes per minute) (amperes).
7. Volts times amperes equals (watts) (kilowatt hours) (alternating current).
8. A dry cell battery (stores) (makes) (uses) electrical energy.
9. In a parallel circuit the electricity has (one) (two or more) (no) paths to travel.
10. In a series circuit with two bulbs and a switch the bulbs are (brighter) (dimmer) (the same) as when they were in the parallel circuit.

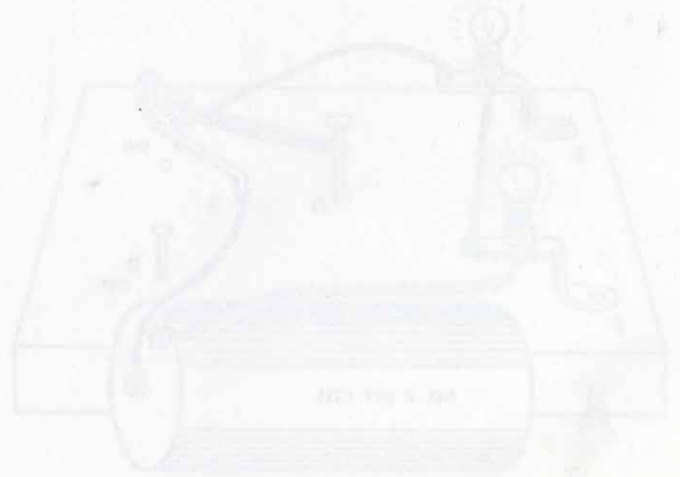



TOOLS FOR ELECTRICIANS

Who goeth a borrowing
Goeth a sorrowing
Few lend (but fools)
Their working tools

Tusser 1524-1580

Whenever a job comes up, it saves time and trouble when you have the right tools and they are all where you can find them. Electrical work takes some special tools and some everyday tools.

If you have ever watched a good electrician at work, you've seen how neatly he stores his tools in a box so every one of them is handy. When a lineman climbs a pole, he has his regular tools in a holster on his belt. Special tools are kept in a box in racks in the repair truck, all ready for instant use. Wouldn't you like to have electrician's tools all handy, ready for use, and know how to use them properly?



Pliers

A pair of electrician's pliers should be part of your kit. Wrap the handles with

Basic Tools for Electrical Work

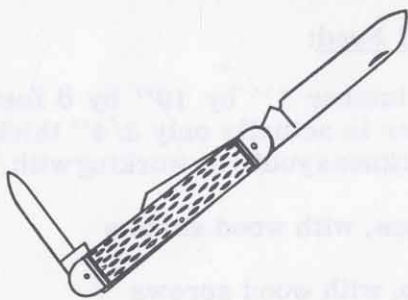

Knife

A good knife with a sharp blade is one of the most useful tools. A camper's or electrician's type knife is probably best because it has other useful parts besides the cutting blades - a screwdriver or punch, for instance. Of course, you'll never use the cutting blades as a screwdriver. This knife should be kept clean, dry, sharp, and free from rust. Put a little oil on the joints from time to time. Remember, "Never whittle toward you and you'll never cut yourself."

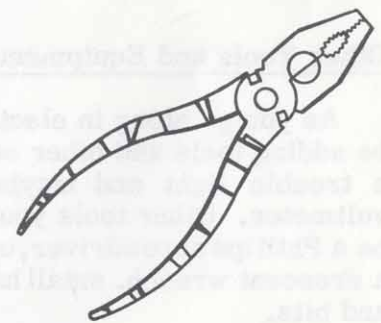
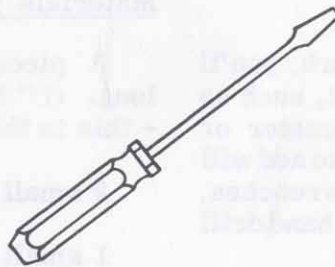

plastic insulating tape. Even though you're not going to work on "hot" electric lines, it pays to play safe. Later on, as you learn more about electricity, you'll want a pair of needle-nose pliers for the fine work.

Screwdrivers

You'll want a screwdriver which has true corners. A 4 to 6 inch plastic handled screwdriver with a narrow blade is best. You'll probably need more than one size to fit the various size screws you'll be turning.

Screwdrivers are easily damaged if you try to use them as chisels and pry bars, or use them in screw slots which are too large for the blade.

You can be hurt by the screwdriver if you try to screw or unscrew things you are holding in your hand. Keep your free hand away from the end of the screwdriver. Place the work on a bench or where it can be handled easily.

Soldering Iron

A good 100 to 250-watt electric soldering iron will be useful. Later on you may want to buy a soldering gun, but unless you are doing a lot of soldering it won't be necessary. A supply of resin-core electrician's solder will be needed. Acid-core solder reacts with copper and in time causes a bad splice.

Tape

Once it was necessary to use two types of tape on splices - rubber tape with friction tape over it. Now there is a plastic tape on the market which takes the place of both and has good insulating quality. It is called electrical tape, or plastic tape, and resists water, oils (which would damage rubber tape), and acids. You'll need a lot of tape in your electrical work, so keep a roll on hand.

Other Tools and Equipment

As you go along in electrical work, you'll be adding tools and other equipment, such as a trouble light and maybe an ammeter or voltmeter. Other tools you'll want to add will be a Phillips screwdriver, open end wrenches, a crescent wrench, small hack saw, hand drill and bits.

You'll also be using some regular carpenter's tools such as hammers, saws, and so on. Unless you use them frequently, you don't need to keep them in your electrical kit.

It's a good idea to start acquiring a supply of electrical parts - lengths of wire, fuses, switches, sockets, plugs, and other items that will come in handy. There are parts you can salvage from old lamps, motors, and other equipment. Such a collection can be a real treasure chest when you need a part in a

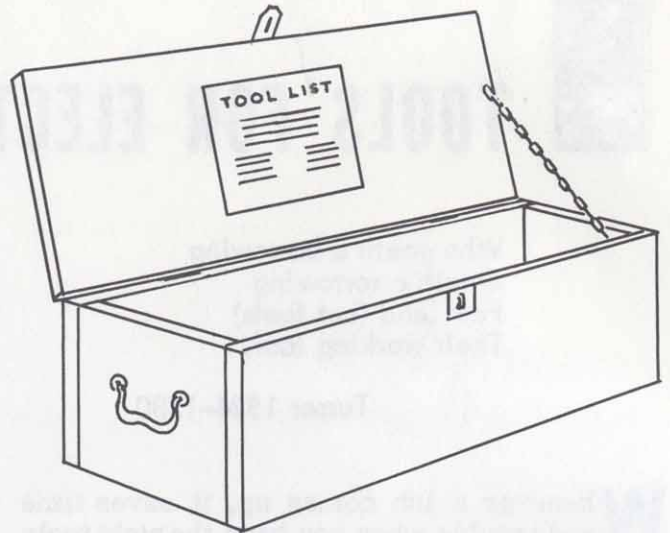

Figure 1. Completed tool chest.

hurry. But be sure to throw away all faulty parts.

WHAT TO DO: Build a Tool Chest

To keep your tools always ready for use, a tool chest will be very handy. It's the 4-H way to work. You'll be surprised how much easier it makes a job when you have your tools, various parts and repair equipment all in one place. You can make the chest (Figure 1) with a saw, plane, screwdriver, pencil, ruler or carpenter's square, and hammer.

Materials You'll Need:

A piece of lumber 1" by 10" by 8 feet long. (1" lumber is actually only 3/4" thick - this is the thickness you'll be working with.)

2 small hinges, with wood screws

1 small hasp, with wood screws

2 small handles with wood screws, or one large handle

1 small chain, 10" to 12" long

Some No. 6 penny finishing nails or wood screws about the same length

Making The Chest:

1. Cut your lumber into the following pieces:

- 1 piece 10" x 18" for top
- 1 piece 8-1/2" x 16-1/2" for bottom
- 2 pieces 6" x 8-1/2" for two ends
- 2 pieces 6" x 18" for front and back

2. Lay out pieces as shown in Figure 2.

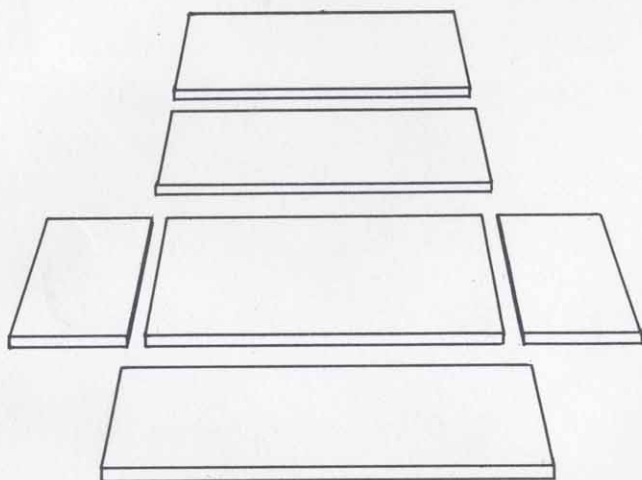

Figure 2.

Then, set up the two end pieces and nail to bottom section. Refer back to Figure 1 as you go along to see that box is shaping up as shown. Nail the front and back sections to the ends along the bottom. Wood screws can be used instead of nails.

3. Lay the top in place and attached hinges to the back side, about two inches in from each end.

4. Attach one part of hasp to the top, and the other part to front board in center. Fasten the handles to each end.

5. Attach chain to the top and front so the top will stay open when chain is fully extended.

Now you can invent your own improvements for your chest. You can paint it, put your name on it, and your club emblem and name if you wish. You can put a rack on the inside of the cover to hold your work sheets and other booklets and materials. You can install special slots or straps to hold each tool in its place along the sides of the box. Maybe you will want to put some partitions in the box to separate various electrical equipment such as wires, fuses, switches, and plugs.

A Working Kit

An accessory which you may want to add to your tool chest is an apron or holster to wear when you are moving around on the job. An apron can be made of a size of cloth about 18 by 20 inches. It should be folded up from the bottom, and sewn to fit the number and size of tools you have. Figure 3 shows such an apron.

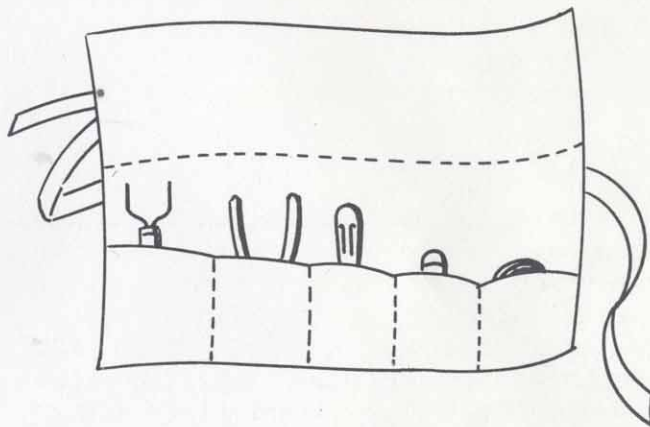

Figure 3. Apron.

You can make a lineman's holster in the same way, using plastic or soft leather. Merely make belt loops by cutting on the dotted lines. A snap fastener will hold the flap over the tools so they won't fall out.

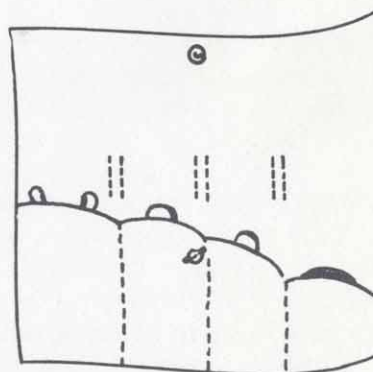
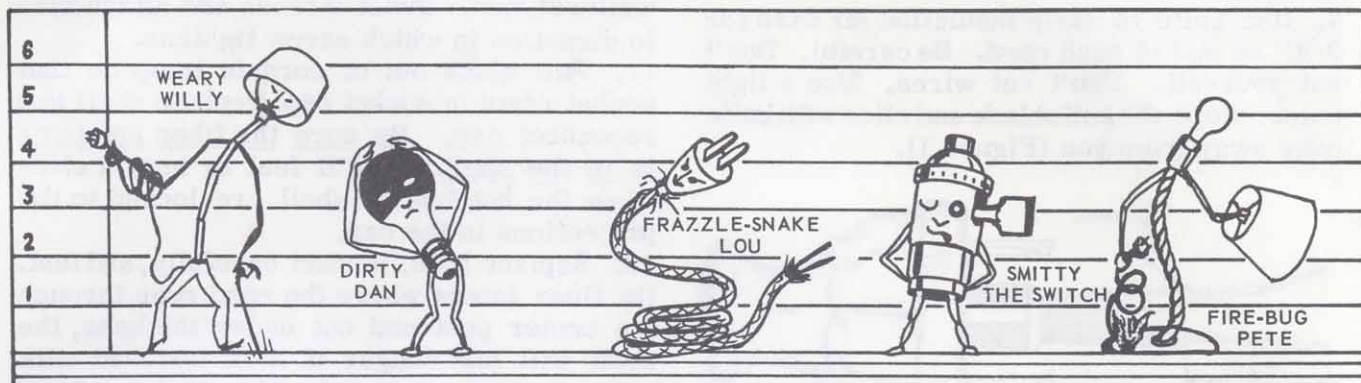

Figure 4. Lineman's Holster



REWIRE A LAMP - BE A LAMP DETECTIVE



The Line-Up of Lamp Suspects

One of the duties of a law officer is to prevent crime. It's that way with the lamp detective. You can become one. In the average home there are lamps about to commit the crime of shocking people, starting fires, and stealing electricity. Some are refusing to do their job well and some are no-goods, sitting in closets or attics, doing nothing. You can put these lamps to working again safely and well. Become the lamp expert in your family.

What's In A Lamp?

A lamp gives light for comfortable and convenient use in the home. It consists normally of a stand, switch, cord, lampshade holder, and shade. Some lamps have diffusing bowls which reduce glare and shadows.

The most common fault found in an old lamp is in the cord, but sometimes the switch or the wiring in the lamp is bad. Look over all the lamps in your home and find the ones needing to be fixed.

WHAT TO DO - Rewire A Lamp

Somewhere around your house you can probably find a lamp that is no longer used or needs repairing. You can make it useful again and at the same time learn how to wire a lamp.

Materials Needed:

Tools: Pocket knife, small or medium screwdriver, and pliers (electrician type is best).

New Lamp Cord: For each lamp to be rewired, you'll need 6 feet of cord plus the length of wire within the lamp stand. Lamp cord wire comes in two sizes, No. 18 and No. 16 AWG (American Wire Gauge). No. 18 is smaller than No. 16, but is adequate for most lamps. Cords are made with surface coverings of several different materials: braided cotton, rayon or silk, and molded rubber or plastic. Braided cord is decorative, but rubber or plastic is easier to work with and is usually more desirable.

Switch: If the switch is bad, get a new one. Socket switches are made with push-through, turn-knob, or pull-chain controls. The pull-chain type is seldom used on modern table or floor lamps. Your lamp may have a separate push-switch in the base. In this case, get the same kind for replacement. Some switches are "3-circuit" switches for use with high, medium, and low-light bulbs.

Plug: Plugs are made of various materials, mostly hard rubber or molded plastic. Some have a shank or handle for better grasping. This type is more desirable. The plug on the old cord may be good, and if so, may be used on the new cord.

How To Do It:

1. If the plug on the old cord is good and you plan to use it, remove it from the old cord.
2. Measure and cut a new lamp cord equal to the length of the cord within the lamp, plus 6 feet.

3. Pass one end of the new cord through the center of the plug. Strip 2 inches of the fabric insulation off cord, or in case of a rubber cord, split cord back two inches. Be sure no bare wire shows in long split section (Figure 1).

4. Use knife to strip insulation off wire for $3/4''$ on end of each cord. Be careful. Don't cut yourself. Don't cut wires. Use a light touch, slope the knifeblade and slice with knife edge away from you (Figure 1).

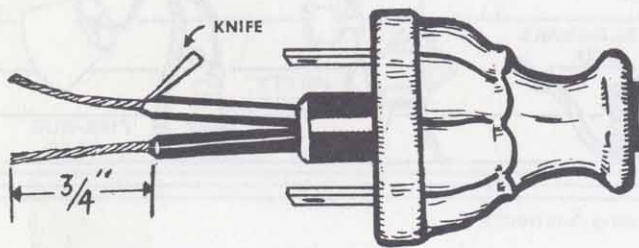

Figure 1 (Ready to Wire Plug)

5. Twist exposed strands of each wire tightly to make a good conductor, and place each conductor around its proper terminal in the direction in which the screw tightens (Figure 2).

6. Tighten screws on terminal posts. Pull cord until slack is out. Lay aside until ready to attach to lamp.

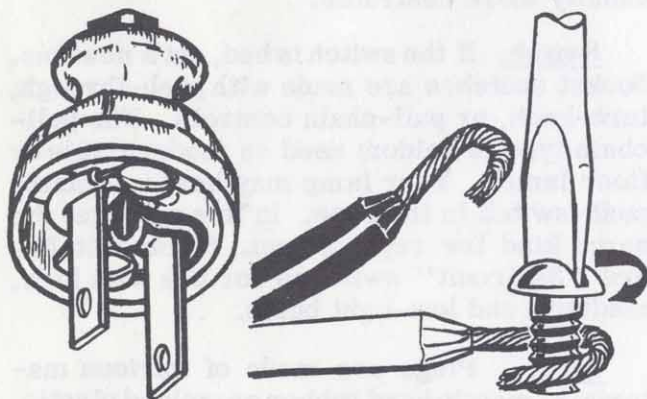

Figure 2 (Attaching Cord to Plug)

7. Remove lamp shade, shade-holder, bulb, and diffusing bowl, if there is one.

8. Separate the metal shell of socket from its cap by pressing on shell at place marked "press," and pull socket from cap.

9. Pull on socket body to get some slack in lamp cord. Loosen screws and detach cord. Pull cord out through base of lamp. You can splice new cord to the old one and use the latter to "string" the new wire.

10. Pass the new cord up through the lamp base and socket cap, tie a simple half-hitch knot in the cord to prevent strain on the terminals, and attach wires to the terminals on the socket (Figure 3). If there is likely to be any strain on cord, use an Underwriters' knot. Twist strands and attach wire in direction in which screw tightens.

11. Pull slack out of cord in lamp so that socket rests in socket cap, replace shell and reconnect cap. Be sure the fiber insulator is in the shell. You'll feel or hear a click when the notches in shell are locked to the projections in the cap.

12. Replace bulb, inspect carefully, and test. (In floor lamps where the cord runs through the center post and out under the base, the cord will last longer if it is fastened with tape so it doesn't rub edge of lamp base when lamp is moved.)

13. If the lamp has a porcelain socket, simply disconnect the wires at the terminals, remove the old wire and connect the new one.

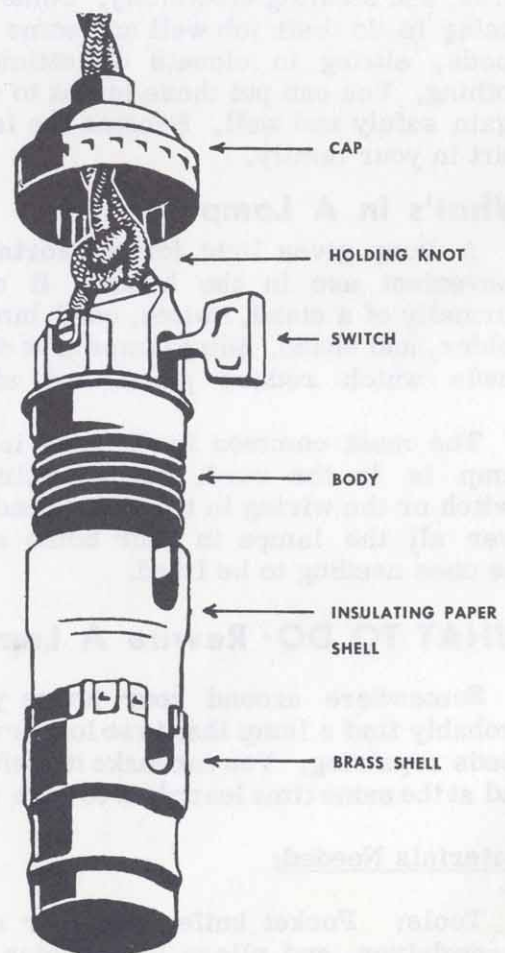

Figure 3 (Socket and Switch Assembly)

What Did You Learn?

Underline correct answers then discuss in the group. (There may be more than one correct answer.)

1. The part of the lamp that usually wears out first is (the socket) (the cord) (the plug).
2. Lamps that waste electricity are those which have (bad wiring) (frayed cords) (dirty shades or bulb).
3. To unplug a lamp you should grasp (cord) (plug) firmly and pull.
4. Wire in lamp cord usually comes in sizes 16 or 18. Size 16 is the smaller (true) (false).
5. In fastening wire around a terminal post it should go around in a (clockwise) (counter-clockwise) direction.
6. When the switch on a lamp is turned off, the electricity only goes as far as (the wall plug) (the switch).
7. An Underwriters' knot should be used (only when there is room for it in the plug) (whenever there is likely to be strain on the cord, even if you have to replace the plug with a larger one).



SUGGESTED DEMONSTRATIONS

Show how to inspect a lamp and its cord. You might tie tags on the cord and lamp at points of danger or failure - at the plug, wear points next to lamp base, bad sockets.

Demonstrate the process of repairing a lamp cord, socket and plug.

Make a board display of the parts of the lamp socket showing cord attached.

Make a display of the types of lamp cords and plugs in common use.

Using two lamps, one with clean bulb and shade, the other dusty, show how the former gives more light.

For More Information

Lamps have an interesting history. Look it up in your local library. Ask someone from your power supplier or electric dealer to talk to the club about the different kinds of lamps. Your leader has or can get additional information on lamps, if you wish.





MAKE A TROUBLE LIGHT

A handy piece of equipment in the home and on the farm is a heavy-duty extension cord with a shielded light and a side outlet on it. When you want to work on the car or tractor in the yard at night, the trouble light is better than a flashlight. You can use it both for light and as an extension cord. It is safer than matches or a lantern, especially around the garage or barn.

It is easy to make a trouble light, and it gives you good practice in electrical work. Of course you can buy one, but you wouldn't have the fun of making it nor would it suit your needs. Trouble lights are not for permanent use - they're for emergency use and to provide light or electricity in places where they are seldom needed. When you find a trouble light being used as permanent wiring, that's the place to install an outlet.

What Size Cord?

Choose the right kind of cord. What length will be best for your various uses? A cord too long may be bothersome to use and store. What will be the heaviest load you are likely to put on the cord, in amperes? Check appliances you may want to connect to it. No. 16 wire can carry 10 amperes safely for a distance of 50 feet, while No. 18 can carry only up to 7 amperes for a distance of 40 feet. You'll want a "hard service" cord, called S, ST, or SO-type cord by electricians. Junior hard service cords, known as SJ, SJT, or SJO, are fine for lighter duty.

Cord, Plug and Guard

A rubber-handled socket should be used for safety and to withstand hard knocks. It should have a switch on it, preferably a push switch in a recess in the handle.

The connector or attachment plug should be of rubber or solid plastic and have a metal cord grip fastened to it. This grip will hold the cord firmly and prevent strain on the terminal connections.



Finished Trouble Light

Get a good lamp guard. If the wire is too light, it may bend and break the bulb when hit or dropped. For the lamp itself, get a rough service lamp. An ordinary lamp won't last long with rough usage.

How to Make the Trouble Light

Tools Needed:

Your 4-H electrician's kit or screwdriver, knife and soldering iron

Materials Needed:

1. About 20 feet of 2-wire, No. 16 heavy duty (hard service)
2. A rubber-handled socket with switch and a side outlet
3. A shielded lamp guard

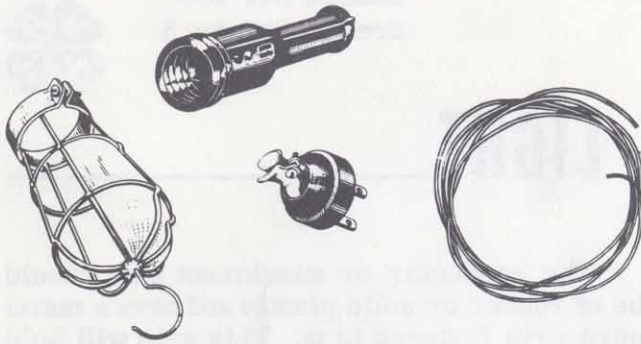

Materials Needed

4. A good connector plug cap, preferably with a clamp-type grip for the cord
5. A rough service lamp bulb
6. Solder and flux

Steps to Take:

1. Remove about 2 inches of the outer covering of cord at one end.
2. Separate the wires and cut away the filler material.
3. Remove $\frac{3}{4}$ inch of the conductor insulation from the end of each wire and tightly twist the strands together to form a firm conductor. Be careful not to cut any of the fine wires. Ends may be soldered.
4. Slide the plug in position on the cord.
5. If there is no cord grip, tie the underwriters' knot (Figure 1). If there isn't room enough, make an "S" loop by passing the wires around the prongs before fastening them to the terminal screws as explained in the next step.
6. Loop the bare part of the wire around the screw in the direction the screw is turned to tighten (clockwise direction). This will prevent the wires from being forced out from under the head of the screw as it is tightened. Now repeat with the second wire, wrapping it around the other prong of the plug.

Connecting the socket.

1. Separate the parts of rubber-handled socket (Figure 2).
2. Prepare the other end of the cord as in steps 1, 2, and 3 above.
3. Insert the cord through the rubber handle and socket guard.
4. Tie the holding knot (underwriters' knot) as explained in Step 5.
5. Connect wires to terminal screws and assemble the rubber-handled socket.
6. Screw in the rough service lamp and test your cord.
7. Put the shielded lamp guard on the socket and tighten the holding clamp until it is firmly in place. You are now ready to use or demonstrate your trouble light.
8. After you've made your trouble light, decide on a good place to keep it where it will be handy for use. Loop it carefully and hang it over a wooden dowel rather than a nail. It will last longer.

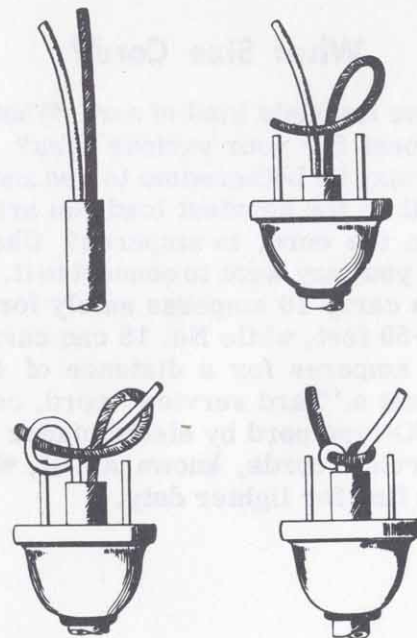

Figure 1

Tying An Underwriter's Knot



Figure 2

Disassembled Light

What Did You Learn?
(Underline correct answer)

1. A Junior Hard Service Cord is known as an (SO-Type) (SJO-Type) cord.
2. You disconnect a cord by (jerking it from the socket) (grasping plug and pulling it out).
3. Brass sockets are unsafe because (they break too easily) (the exposed metal can cause short circuits).

4. Rubber-covered cord is safer for emergency cords than fabric because (it will stretch) (it will insulate and protect the wires inside).
5. In a trouble light (any kind of bulb will do) (a rough service bulb is best).

Ideas for Demonstrations and Exhibits

1. Show how to make your trouble light and a method of storing it.
2. Show a safe trouble light, and an unsafe trouble light with danger points marked.
3. Show cutaway pieces of different types of cord.

For More Information

Ask your power supplier, county highway engineer, police official or leader to tell you about various types of portable emergency lights and their uses.





WHAT MAKES MOTORS RUN

What makes an electric motor run? Can you make an electric motor that will run? Certainly you can, and by doing so you'll learn why it runs. It won't be mysterious any more and you'll be ahead of all the millions of people who use motors every day and never know why or how the motor converts electrical energy into useful power.

Motors Are Magnets

You know how one end of a compass needle always points to North. No matter how you turn the compass, the same end of the needle always swings to the North. The earth itself and that small compass are both magnets (Figure 1). Each has a North pole and a South pole. Around the poles of each there are magnetic fields, invisible lines of force that attract and repel.

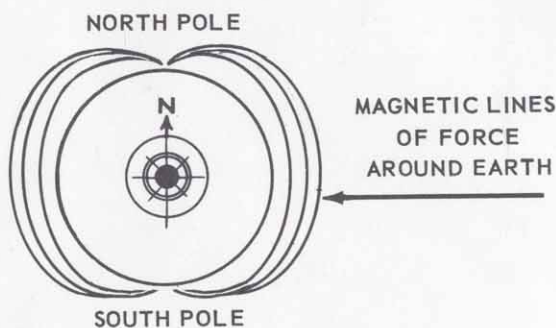

Figure 1. The same end of the compass needle always points to the earth's magnetic North Pole.

The N poles repel each other and so do the S poles. The N and S poles attract each other. In other words, opposite poles attract; poles that are alike repel each other.

Lay 2 bar magnets on a table side-by-side. If both N poles are at one end, they'll



repel each other and almost flip around until there's a N pole lying next to a S pole (Figure 2).

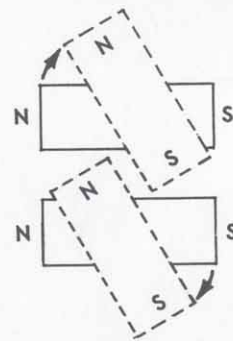

Figure 2. Small bar magnets laid side by side move so that the North pole of one is near the South pole of the other.

Now suppose we place one of the bar magnets on the table. The other, we'll fix on a pivot so it can spin around. This one we'll move so its N pole almost touches the fixed magnet's N pole. As soon as we release it, the movable magnet will spin around so its S pole will be near the N pole of the

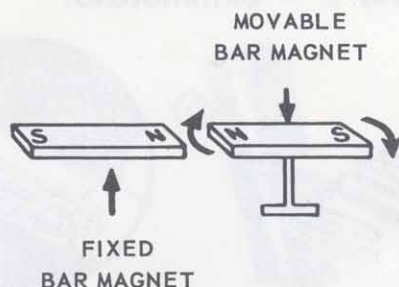

Figure 3. A movable bar magnet pivots so its South pole is near the North pole of a stationary magnet.

stationary magnet. That's an electric motor - almost.

It's not quite a motor because the rotating magnet will just move as far as it has to in order to get the opposite poles together. You might be able to cause the movable bar magnet to make turn after turn. You could do this by turning the fixed magnet quickly end for end. This wouldn't be very practical as a motor.

We Can Improve It

If we could change the pole on one end of the rotating magnet just as soon as it reaches the attracting pole, it could make a complete circle. In doing that, the pole at the near end of the rotating magnet would be repelled by the stationary magnet and pushed away. As soon as the opposite end of the rotating magnet would come into the magnetic field, it would be drawn to the stationary magnet. In order to keep the "motor" running, we would have to constantly change the poles at each end on every half revolution.

We Need An Electromagnet

We can't reverse the poles on simple bar magnets, but we can on electromagnets. We can make one by wrapping a wire several times around an iron core to form a coil. This magnet will also have a N and a S pole when connected to electrical current. The big difference is that the poles can be changed instantly by reversing the current in the wire.

Switching Poles Automatically

The rotating electromagnet will have to be connected to the 2 wires through which we pass the current. Since it's rotating on a center shaft, we can't have a solid connection. Instead we have to extend the wires from the coil out along the shaft and let the electric contact be made with brushes which touch the wires along the shaft.

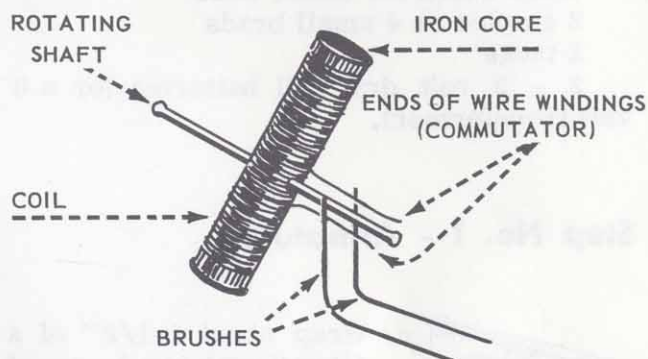

Figure 4. A rotating electromagnet changes poles as contacts are made first one way, then the other.

This is a simple way to reverse the current in the coil of the electromagnet.

Increasing Efficiency

Instead of using only one pole of a stationary magnet, we can use both. This is done by shaping the stationary magnet around the path of the rotating electromagnet. This way we have the benefit of both the attracting and repelling forces from both poles. The effect is doubled.

We can also wrap wires around this circular iron and make an electromagnet of it. But when we wire this magnet we use no brushes because we want the current to flow in one direction only.

The stationary electromagnet is called the field. The rotating electromagnet is the armature.

WHAT TO DO: Make A Motor

Tools Needed:

Pocket knife, hammer, vise (or 2 pairs of pliers).

Materials Needed:

- 1 roll of No. 24 enameled wire
- 1 roll of electrician's tape
- 3 - 4" (20-penny) nails
- 4 - 2-1/2" (8-penny) nails
- 4 - 3" brads (10 penny)
- Wood board for motor base
- 2 staples or 4 small brads
- 2 tacks
- 2 - 3 volt dry cell batteries (or a 6 volt transformer).

Step No. 1 - Armature

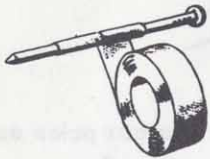

Wrap about 1-1/2" of a 4" nail with two layers of tape. This will be the shaft.

The iron core will be made of two pairs of 2-1/2" nails. Wrap tape around each pair with heads and points alternated.

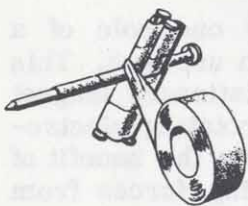
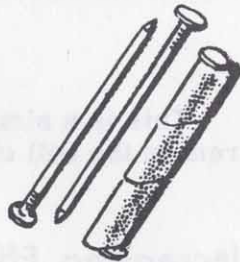

Center both pairs on each side of the shaft. Place them about 1" from the head of the shaft nail. Wrap them together with two layers of tape from tip to tip.

Start at the shaft and wind No. 24 enameled wire to one end and back. Then do the same on the other end. Always wind in the same direction. Leave 6" of spare wire at start and finish.

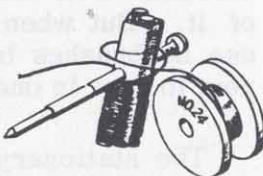

Step No. 2 - Commutator

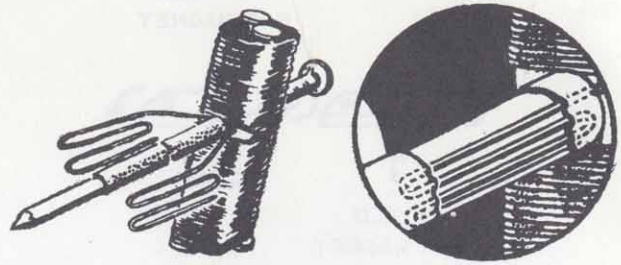

Scrape all insulation off the ends of the wire. Bend the bare ends back and forth as shown. Lay them flat over the taped shaft - one on each side of the shaft.

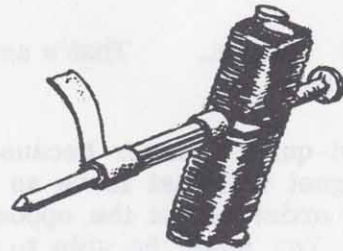

Hold the commutator down with narrow strips of tape. Wrap tightly near the core and at the opposite end.

Step No. 3 - Field

Make the core by bending two 4" nails in the middle at right angles. Space the heads about 3" apart to form a horseshoe. Wrap together with two layers of tape.

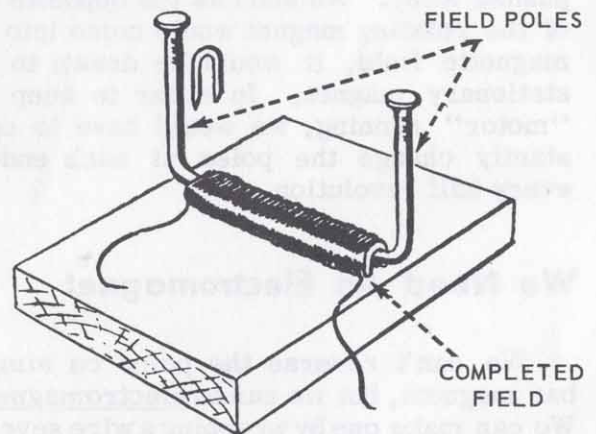
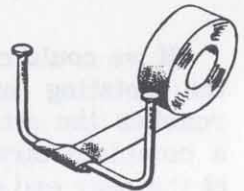

Wind about 400 turns of wire around the center. Leave 4" of spare wire at start and finish. Attach to wood base with staples at each end of the wire. Small brads, bent over, will do just as well.

Step No. 4 - Armature Supports and Brushes

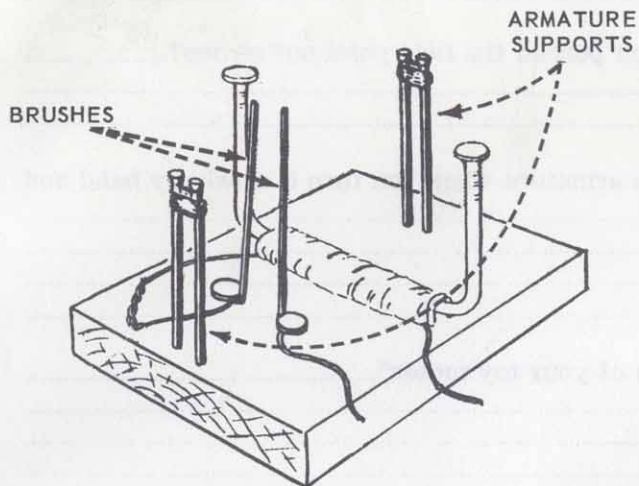

Scrape the insulation from the ends of two 6'' pieces of wire. Tack them to the base and bend them as shown to make brushes.

Drive two pairs of 3'' brads into the base about 3-1/4'' apart and in a line midway between the field poles. Wrap wire around the supports to form armature bearings.

Scrape insulation off ends of wire from the field. Connect one end to a brush wire.

Assemble As Shown

Adjust the position of commutator and tension of brushes against it for best operation.

Take the armature off the motor and connect the commutator wires to a dry cell battery. Test the polarity of each end of the armature with a compass. Switch the connections on the commutator and test again. See how the compass needle changes direction?

With the armature still off, connect the field coil directly to the dry cell. Test the polarity of each end of the field with the compass. How can you reverse the polarity? Try it. It's easy.

Reassemble the motor again and start it. Push the field poles slightly out of alignment with the turning armature. What happens to the motor's speed? Can you tell why?

This time, push the field poles completely out of the way. Test the polarity of the armature as you slowly turn it by hand. Do you see what happens and why it does?

Try to reverse the direction of rotation of your motor by reversing the connections at the battery. What happens? Can you explain why?

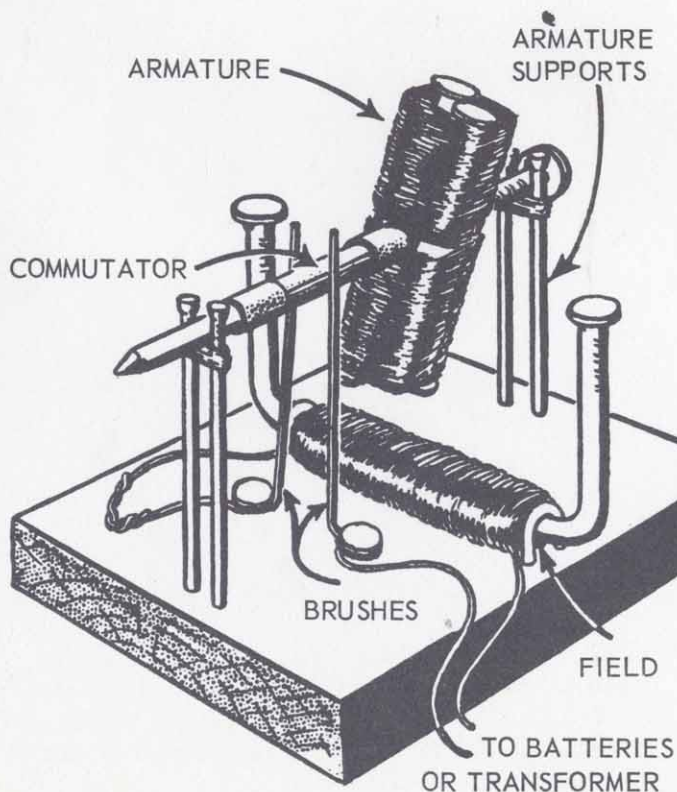

Demonstrations You Can Give

Make a display board showing the parts of the toy motor and explain how each part works compared with the parts of a commercial motor.

For Further Information

There are several other types of toy motors you can build. Your club leader or power supplier can help you find information about them.

1. Did your toy motor run?
2. Did your motor speed up or slow down when you pushed the field poles out of line?.....
Why?.....
.....
3. What happens to the magnetic polarity of the armature when you turn it slowly by hand and check it with a compass?.....
.....
.....
4. How can you reverse the direction of rotation of your toy motor?.....
.....
.....

Is there another way too?..... What is it?

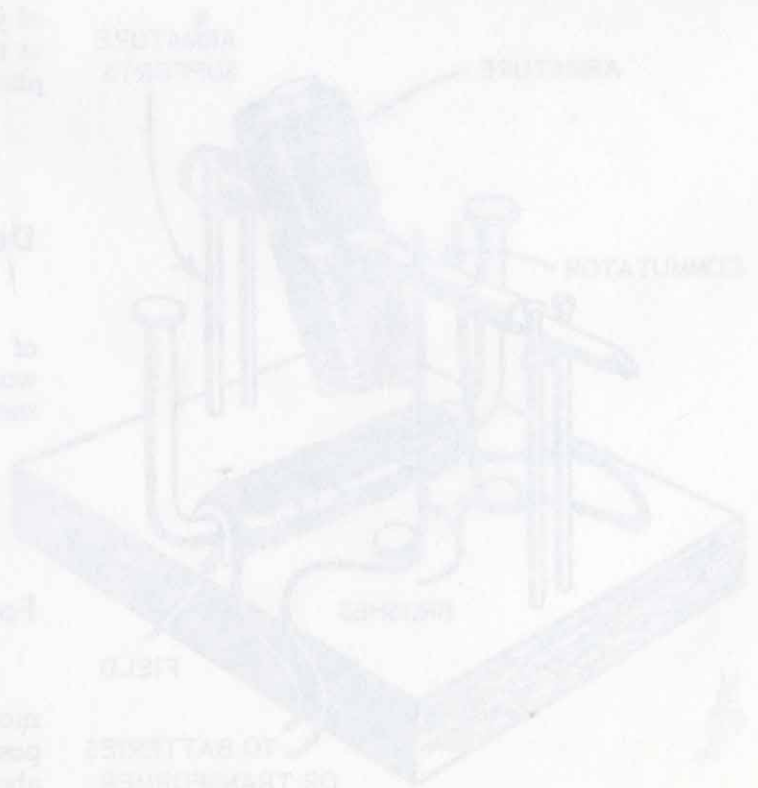

Align with the compass. What happens to the needle's north? Can you tell why?

This time, push the field poles completely out of the way. Test the polarity of the armature as you slowly turn it by hand. Do you see what happens and why it does?

To reverse the direction of rotation of your motor, reverse the connections to the motor. What happens? Can you explain why?

Explanations for Can Give

Make a display board showing the parts of the toy motor and explain how each part works connected with the parts of a commercial motor.

For further information

There are several other types of toy motors you can build. You can learn or guess further on help wanted information about them.



LESSON NO. B-6
Credit Points 3



TAKING CARE OF ELECTRIC MOTORS

Through the magic of electric motors, much of our work is done faster and better at lower cost than we could do it without the help of the electric motor. People who use motors and treat them properly have much more time for other work and for leisure time activities. A 1/4-horsepower motor running quietly and steadily hour after hour will do the work of one man, and operate all day for about 5 cents without tiring. On many jobs it will work without "supervision", turning on and off automatically, as required. It does this on water pumps, in heating and cooling units, and on fans and similar appliances.

All that a motor needs to do its work is electricity and a little care. Let's see what you can do to give proper care to motors in your home and on your farm.

You'll Need

A light oil (SAE 10) for motors of less than one horsepower and a slightly heavier oil (SAE 20) for larger motors. See if you need grease for cups which may be on large motors. If so, be sure you use ball-bearing grease and not ordinary cup grease. Cotton waste or clean rags will be needed for wip-

MOTOR			
STYLE			
SERIAL	FRAME		
THERMAL PROTECTION	TYPE		<input type="checkbox"/>
OIL YEARLY AFTER 2 YEARS FOR NORMAL OPERATION; OIL TWICE A YEAR FOR FREQUENT OPERATION.			
HP	PH	TYPE	
RPM	SERVICE FACTOR		
CYCLES	CODE		
VOLTS			
AMP	S.F. AMP		
DEG C	HOURS		
HOUSING			
NP70750-B		MADE IN U.S.A.	

Some motors have instructions for oiling on the nameplate.



ing off the motors, and a tire pump or vacuum cleaner for blowing out the dust or dirt.

WHAT TO DO

1. First, make a list of all the electric motors that work for your home. You may wish to make a separate list for your farm buildings. You'll probably be surprised at how many there are. Don't forget the sewing machine, the refrigerator, the freezer, the vacuum cleaner and other small but important motors. Don't touch any motor that is running. Disconnect them before you touch them.

2. Make a motor service chart with columns headed: Use, Location, Horsepower, Volts, Amperes, Service Required, Date Serviced and What was Done. (See sample) Then list all the motors that require any servicing. Some will have the instructions on the motor or appliance; the instruction booklet that came with the motor or appliance will also tell what servicing is required.

Step 1. Plan the job. Start with the motors in the home. Then you can care for the motors on the farm.

Step 2. Be sure that any motor on which you are going to work is disconnected. Then wipe the outside case clean with a cloth. If the motor has openings in the end, use a vacuum cleaner to suck out dust, dirt or chaff. A tire pump may also be used to blow out this dirt. If you use compressed air, be sure the pressure is not high as it may damage wiring inside the motor. Dust-proof motors should be used in dusty or dirty places.

Step 3.

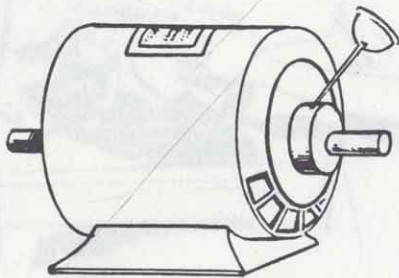

If there are oil holes, oil according to the manufacturer's instructions.

If there are no instructions, remember a little oil goes a long way as far as motors are concerned. Motors of less than one horsepower require only 3 or 4 drops (not squirts) of oil every 3 or 4 months if the motor is used frequently. Too much oil can damage the motor. It spoils the insulation.

If there are no oil holes or grease cups on the motor, it is probably lubricated by means of grease sealed in the bearings at the factory, or it may use greaseless bearings, and does not need to be oiled or greased periodically. Indicate on your chart all motors which need periodic care and see that it is given according to schedule.

Wipe away any excess oil or grease. Be sure oil holes are capped or covered.

Step 4. Reconnect motor and run for a moment.

Step 5. Record on the chart the date you serviced the motor and what was done.

What Did You Learn?

How many motors are there in your home?
_____ On the farm? _____

How many motors need regular oiling or grease? _____

How many are less than one-horsepower? _____

SAE Oil _____ is used to oil motors up to 1/2 horsepower. How much oil? _____

SAE Oil _____ is used for larger motors.

Demonstrations You Can Give

1. Show how to clean a small motor.
2. Explain proper lubrication of motors.
3. Using the chart prepared in this work sheet, give a talk about the motors that work for you - the job each one does, which ones need oil or grease, which need no attention, and why, etc.
4. Use a homemade toy motor to explain "what makes motors run."
5. Show proper way to replace worn cord on a small motor.

For Further Information

Ask your county Extension agent or 4-H leader for more literature on motors. They can help you obtain a film or a speaker such as a power supplier, a local electric dealer, or electrical contractor to discuss motors.

Also visit your public library and see a science teacher for more information on motors.



READING THE ELECTRIC METER

There is no question but what electricity is one of the lowest cost services in the home and on the farm. A few pennies worth of electricity will provide the power to run machines that take the place of a man or of several men working all day. However, we all like to know what things cost.

Sometime you may have to decide between different methods - man, horse, gasoline engine or electric motor power. Then you'll want to know how to figure the cost of electricity, as well as the cost of the original equipment. First of all, you should know how to read an electric meter.

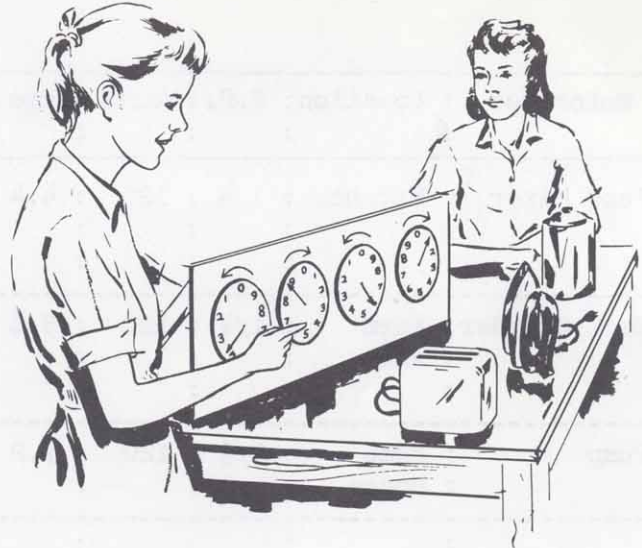

Reading a Meter

Electric meters read in kilowatt hours, just as a water meter reads in gallons and a gas meter in cubic feet. A kilowatt hour is the electrical energy consumed by 1000 watts of electricity used for one hour. Ten 100-watt light bulbs burning for one hour would use one kilowatt-hour -- one kwh.

kwh; the third, to 1000 kwh; the fourth, to 10,000 kwh. After that, the meter starts over again. To take a reading you must read all four dials of the meter, from right to left.

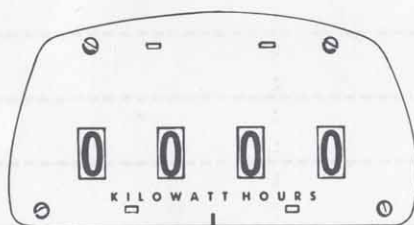

Figure 1. Some meters give the reading directly, like the mileage total on a speedometer.

Some meters are read directly, as shown in Figure 1. The more common type has four dials which are read from right to left - just the opposite from the way things are usually read. The hand on the extreme right turns clockwise, the next hand turns counterclockwise, the next clockwise; the last hand on the left turns counterclockwise.

The first dial on the right can register up to 10 kilowatt-hours; the second up to 100

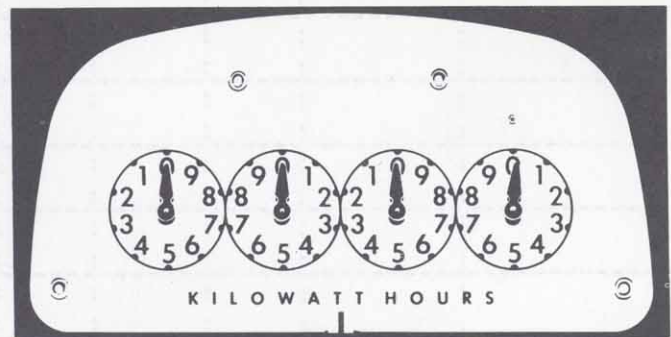

Figure 2. Meter dials are read from right to left.

To read each dial, you use the number last passed by the dial hand. This may not be nearest the hand. For instance, if the pointer has passed 6 and is almost on 7, you read it as 6. Write down the figures in the same order you read the dial, from right to left. Practice reading the meters shown in Figure 3 on the following page.

What's Your Electric Bill?

Meters aren't set back each month when the meter reader comes around. The differ-

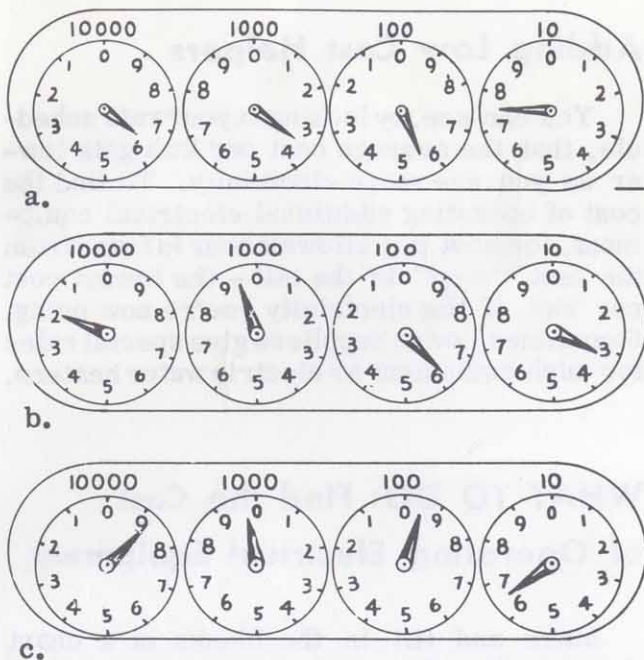

Figure 3. See if you can read the above correctly. The answers are shown in a box on the next page.

ence in the readings from one month to the next shows how many kilowatt-hours have been used. If you know your electric rates, you can figure your bill by yourself. Your power supplier will furnish you with a rate schedule on request.

It will be interesting to you to find out how much it costs to operate the various electric appliances in your home. A sample rate schedule is shown in Figure 4.

Demand Charge	
\$2.10 per kilowatt.	
In lieu of a demand charge, customers without demand meters pay one cent per kwhr in addition to the net energy charge (See Rate 6).	
Net Energy Charge	Kwhrs
4.45¢ per kwhr for the first	50
3.25¢ per kwhr for the next	450
2.65¢ per kwhr for the next	2000
2.25¢ per kwhr for all over	2500
The gross energy charge is 10% more than the sum of the net energy charge and the fuel adjustment.	
Minimum Charge: \$1.00 net (\$1.10 gross) month.	
Minimum Charge	net

Figure 4. Sample rate schedule. Note that as the use of electricity increases, the average cost per kwh is reduced.

Estimating Operating Costs

To find the cost of operating any single appliance, three steps are necessary:

1. Learn the wattage of the appliance.
2. Estimate how many hours the appliance is used.
3. Find its operating cost.

To Find Wattage:

Watts, you know, are the measure of electrical power. They are the product of voltage (pressure) times amperes (rate of flow). Volts times Amps equals Watts. The nameplate on the appliance will give the voltage required for proper operation as well as either amperage or watts. If it gives wattage, you have the information you want. Otherwise you must multiply volts times amps to get the wattage. When voltage is given as 110-120, use 120 as your voltage. 120 volts is nominal today.

How Much Will You Use?

Now that you know the wattage of the appliance, multiply this figure by number of hours the equipment operates in one day. Divide this by 1000 to get the kwh. Now multiply the result by the number of days the appliance is used each month. This tells you the number of kwh used by the appliance during the month.

Example No. 1

Yard Light: 300-watt lamp

Amount of use: 3 hours per night.

Multiply lamp wattage times hours of use per night to get watt-hours per night.

$$300 \text{ times } 3 = 900 \text{ watt-hours per night.}$$

Divide watt-hours by 1000 to get kwh per night.

$$900 \text{ divided by } 1000 = .9 \text{ kwh per night.}$$

Multiply kwh per night times 30 to get kwh per month.

$$.9 \text{ times } 30 = 27 \text{ kwh per month.}$$

If the yard light is used 3 hours per night, it consumes 27 kwh per month.

Example No. 2

Coffee Maker: 120 volts, 550 watts (from nameplate)

Amount of use: 1/2 hour per day.

Multiply wattage of coffee maker times hours of use per day to get watt-hours per day.

550 times 1/2 hour = 275 watt-hours per day.

Divide watt-hours by 1000 to get kwh per day.

275 divided by 1000 = .275 kwh per day.

Multiply kwh per day times 30 to get kwh per month.

.275 times 30 = 7.250 kwh per month.

If the coffee maker is used 1/2 hour daily, it consumes 7.25 kwh per month.

Calculate Operating Cost Per Month

Now that you know the number of kilowatt hours an appliance uses, go to your rate schedule and your electric bill to see what the average kwh costs. Find the average cost of 1 kwh by dividing the amount of your bill by the total number of kwh used in a month.

Example: 410 kwh used.

\$14.35 total monthly bill

Average cost per kwh equals \$14.35 divided by 410 kwh - 3-1/2 cents per kwh.

Therefore, the cost of operating the coffee maker for a month would be 3-1/2 cents times 7.25 kwh - 25.4 or 25 cents. Cost of operating the yard light would have been 94.5 or 95 cents a month.

(a) 6357 (b) 1963 (c) 8996

Correct answers to the meter readings shown on the preceding page.

Adding Low Cost Helpers

You can see, by looking at your rate schedule, that the average cost per kwh gets lower as you use more electricity. To find the cost of operating additional electrical equipment, the cost per kilowatt hour is found from the last "step" in the bill - the lowest cost per kwh of the electricity you're now using. Sometimes power suppliers give special rates for such equipment as electric water heaters.

WHAT TO DO: Find the Cost of Operating Electrical Equipment

Make and fill in the blanks of a chart showing the electrical equipment you have and the operating costs per month.

Make a chart for the home (refer to chart one). Show the probable operating cost of equipment you might add to what you now have.

Demonstrations You Can Give

Show how to read a meter, making one with plywood or cardboard. Dials can be painted on the main board. Arrows can be attached so they will revolve to give different readings.

Show how to find the wattage of various types of equipment.

Show how to figure the cost of the average kwh in a home.

For Further Information

Your leader can get additional material for you or you may want to have someone from your power supplier talk to your club, telling about meters, how they work and how they are regularly checked for accuracy.



IRONING IS FUN

WITH THE MODERN HAND IRON

When you are getting ready to go to school or to a party, it probably gives you a good feeling to put on a clean, freshly-ironed skirt, blouse or dress. But did you ever think about the electric iron that helps so much to give you that well-dressed feeling? When you were younger, you may have had a play iron and pretended to iron your doll's dresses. Now you are old enough to learn about real irons - the different kinds of irons, how the iron heats, the kind of cord needed, the type of outlet necessary, how to use safety rules when you iron, and even how to help with the ironing.

Important Things to Know

There are many different irons, but the two kinds most important for you to know about now are the regular dry iron and the combination steam-and-dry iron.

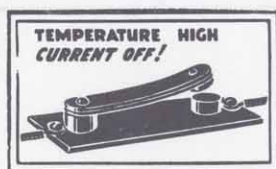
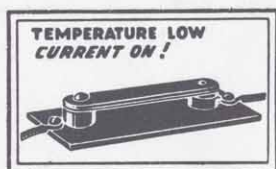

The thermostat keeps the iron at an even temperature.

It isn't weight alone that makes an iron do its job, but the heat of the iron. The heat is given off in the sole plate. The automatic iron has what is called a thermostatic control which holds the temperature of the iron at the heat you want. Some clothes need to be ironed with a very hot iron, while others need only to be pressed lightly with a cool iron. The thermostat keeps the iron at an even temperature after you set it for the heat you want. The thermostat is the heart of the iron.

Take a look at the iron used in your home. It isn't heavy to lift, and has a handle that fits your hand easily. It looks graceful and has a smooth bottom, called



the sole plate. And it may have a narrow, pointed tip which is helpful in ironing pleats, corners and gathers.

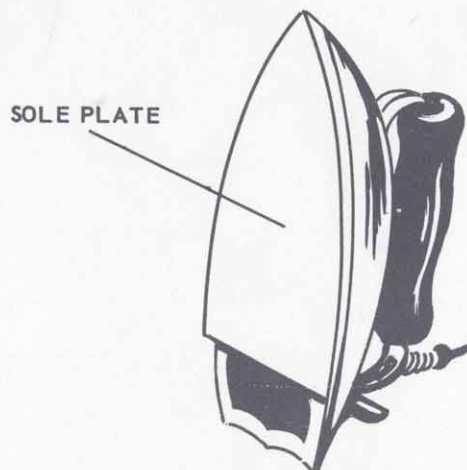

Your iron has a smooth bottom called the sole plate.

The Iron and Safety

If you are going to learn to do some ironing yourself, the most important thing for you to remember is SAFETY. You should read all about the iron first in the instructions which came with it.

Never use an iron carelessly. Remember the safety rules:

1. An iron should never be left even for a few minutes without being disconnected. Turn off by removing the plug from the outlet, or by turning the control lever to "off."

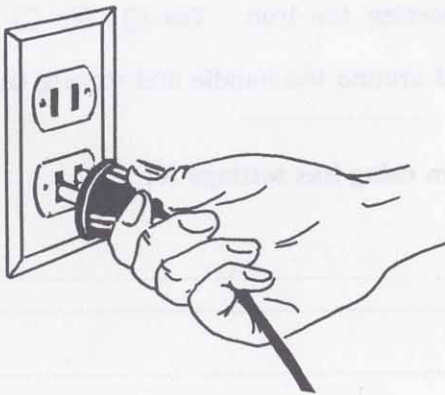

Take hold of the plug - not the cord - when you disconnect it from the outlet.

2. Let the iron cool before putting it away.
3. Wrap the cord carefully around the iron after it is cold.
4. Always stand the iron where it will not fall off on a child or pet or your own toes.

WHAT TO DO: Learn About Your Iron

Materials Needed: An automatic iron, some old play clothes, towels, napkins or handkerchiefs, and an ironing board.

Steps to Take:

1. Watch an experienced person iron.
2. Ask questions about what clothes need to be sprinkled.
3. Study the thermostat settings on the dial or indicator.



Most irons have a dial to set for the proper heat for different fabrics.

4. Ask about the kind of fabric each piece of clothing is - cotton, linen, silk, nylon, etc. - and why the iron should be at high heat for some, cooler for others.
5. Set the thermostat for the amount of heat needed, and with an older person watching you, iron some handkerchiefs, napkins, bath towels, and a pair of play shorts or blue jeans.
6. During a month iron some of these articles for your family, keeping a record of how many you do and what they were.
7. Take care of your iron. Be responsible for storing it.

Date	No. Articles Ironed	Type of Article	Stored Iron Properly (check)

IRONING IS FUN

IRONING IS FUN

1. I (use) (do not use) an adjustable ironing Board at home. If I do, I adjust it to the height that just clears my knees easily as I sit in a comfortable chair. Yes No
2. There are three kinds of irons usually used—dry iron, steam iron or a combination steam or dry iron. I use a iron.
3. I (have) (do not have) the instruction book. (If you do, read about the iron.) I know the iron's parts by their correct names. They are
4. I disconnect the iron if I leave it even for only a minute. This is a safety measure as fires have been known to start from irons left connected. Yes No
5. I take hold of the plug—not the cord—when disconnecting the iron. Yes No
6. I wait until the iron is cold before wrapping the cord around the handle and storing the iron because
7. Most irons have a thermostatic control. The iron I am using has settings for
8. The purpose of the thermostat is
9. These fabrics need high temperature.
 These fabrics need medium temperature.
 These fabrics need low temperature.
10. These fabrics need sprinkling.
11. The heat and smoothness of the sole plate smoothes the wrinkles. Pushing down on the handle or moving the iron rapidly only makes ironing hard work. I will iron slowly and steadily arranging and moving the garment with the left hand while guiding the iron with the right hand. (Or the other way for the left handed.) Yes No
12. I have watched an experienced person iron. Yes No
13. I have practiced on handkerchiefs, napkins and pillow cases.

Booked Iron Property	Date of Purchase	Make	Date

14. Here is my record of ironing for one month.

Month

Your Name

Date I have ironed:

--	--

Demonstrations You Can Give

1. Show a dry iron and a steam-and-dry iron. Tell the difference between them and when each is to be used.

2. Display garments that look nice because they have been ironed properly, and those that have been ironed improperly. Explain about the heat, thermostat, type of iron and why results differ.

3. Give a talk on ironing safety.

For More Information

At a club meeting ask a parent to give a demonstration of ironing different articles. Some power suppliers or dealers have people who will demonstrate the proper way to iron, and how to care for irons.



LET'S BE FRIENDS WITH ELECTRICITY

Plan a Hazard Hunt

Electricity can be your important lifelong friend and helper, so you will want to know all you can about it and how to treat it properly. However, careless and improper use of electricity can do a lot of harm. Used properly, and treated with respect, electricity can do wonderful things to help you every day in many ways.

For safe and proper use of electricity, all wiring, fittings, insulation, cords and plugs must be in good condition. You can be a detective and track down defects in any such type of electrical equipment that you may be using in your home or on your farm.

When you find anything that is wrong, and know where it is, and know what to do about it, you can very likely correct the condition yourself, such as replacing a worn extension cord with a new one. If you find defects in permanent wiring, or some places where wires are bare or terminals are needed, you should tell your parents about them.

SAFETY FIRST, remember, should always be on your mind when working with anything electrical.

WHAT TO DO:

1. Have A Hazard Hunt

Go on a Hazard Hunt to see how many electrical hazards you can find. Look for defects such as broken insulation, worn cords, splices that are not properly soldered and taped, loose connections, or switches that aren't working properly.

There are many ways to have a Hazard Hunt. Choose the method that will be the most fun. Use the Hazard Hunt Guide in this outline to check your home, and other buildings. Maybe you'll want to have a friend help check your home, then you help him check

his. Or, why not give each member of your family a Hazard Hunt Guide and have a contest? Parents may want to team up against you and other younger members of your family to see which team can find the most electrical hazards in some set time--say 30 minutes.

Have a Hazard Hunt Committee in your club check all member's homes and buildings and report its findings at the next club meeting.

To Make It More Fun

1. Put a hazard tag, like the one shown, (Figure 1) by each hazard that is found. Leave it until the hazard is corrected. Have another contest to see which member of the family corrects the most hazards.



Figure 1

2. Report on your Hazard Hunt at the next club meeting. Tell about the Hazards found, and what you have done or plan to do about them.
3. Suggest that the entire club have an Electric Hazard Hunt at your club meeting places or any community building. This could be part of one meeting.

4. Have a contest between two teams in the club to see which team can get the most homes in your community checked by the Hazard Hunt Guide. Losers could give a party for the winners.

2. Get Others Interested

Promote a community Electric Hazard Hunt. Enlist the support of power suppliers, electric supply and equipment dealers, schools, newspapers, radio and television stations.

What To Look For

Make a complete tour of your home and other buildings and see how many hazards you can locate. When you find a hazard, put a tag near it to mark it.

SAFETY TIPS

Put hazard tags near the hazard but not directly on broken or frayed wires, insulators, fittings, or other wiring equipment. Do not touch them either. Badly-frayed wires should be disconnected immediately from the power supply. In this way, you will not expose yourself to shock by accidentally touching an exposed live wire that may be carrying current.

4-H Electric Hazard Hunt Guide

Wiring and Protective Devices

1. Cable or conduit splices not in boxes _____
2. Cable or conduit not securely clamped in boxes _____
3. Conduit or armored cable not properly grounded _____
4. Cracked or broken insulators (Figure 2) _____
5. Wire not completely covered with insulation _____
6. Worn insulation on wire _____

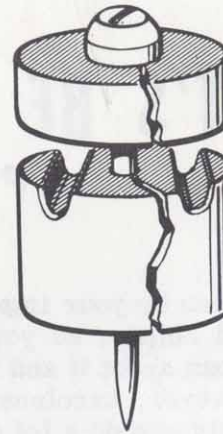

Figure 2

7. Old unused wiring not yet removed _____
8. Outlets, junction and switch boxes not securely fastened and covers not in place _____
9. Switches not working properly (sparks fly as switch is flipped) (Figure 3) _____
10. Fuses not of proper ampere rating for circuit _____
11. Extension cord used in place of permanent wiring _____
12. Pull chain socket without an insulating link in the chain _____
13. Pull chain socket near plumbing fixtures or where hands may be wet or one may stand in water _____

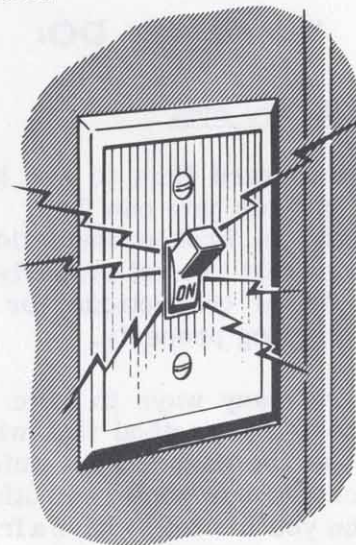

Figure 3

- 14. No moisture-proof cords for outside weather conditions or heavy rubber cords for motors and motor driven appliances _____

Lighting

- 1. Fixtures in farm buildings installed so that they might be easily damaged _____
- 2. Lights in haymows and other dusty locations not protected by dustproof globes _____
- 3. Outside sockets not water-proof _____
- 4. Heat lamps not properly supported by non-current carrying wire, chains, or brackets (Figure 4) _____
- 5. Light bulbs not frosted, shaded, or placed so that light is diffused to prevent glare _____

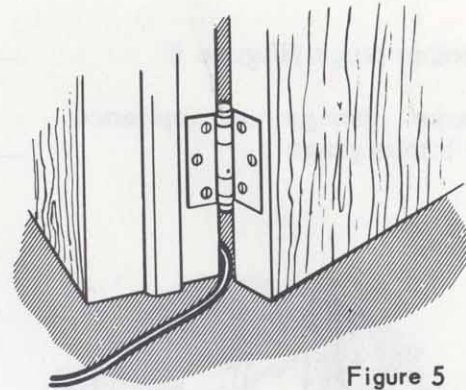

Figure 5

- 4. Extension cords or lamp cords should use underwriters' knot (Figure 6) _____

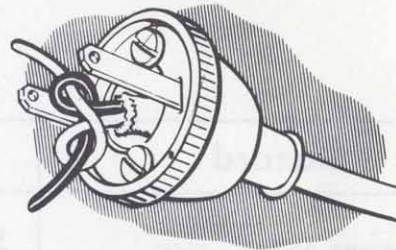

Figure 6

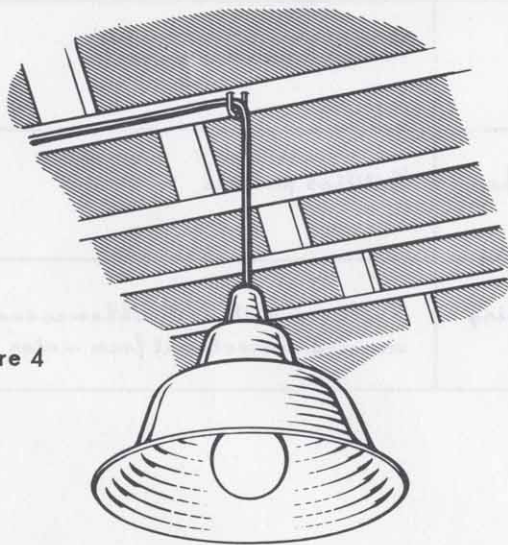

Figure 4

- 5. Plug connections fuzzy (Figure 7) _____

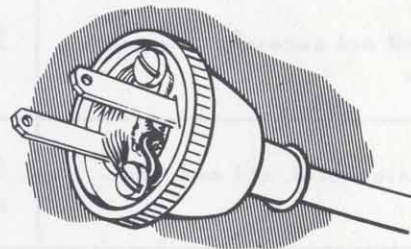

Figure 7

Auxiliary Wiring

- 1. Outlets overloaded--in other words, "octopus wiring" _____
- 2. Extension cords placed under rugs _____
- 3. Extension cords run through doorways (Figure 5) _____

- 6. Extension cords run over heaters or radiators _____
- 7. Extension cords, or appliance or lamp cords, worn or frayed _____
- 8. Heating appliances without regular asbestos covered wire _____
- 9. Open sockets or outlets where a baby or small child might stick a finger or metal toy _____

- 10. Broken plugs (Figure 8)
- 11. Loose prongs on appliance or lamps plugs

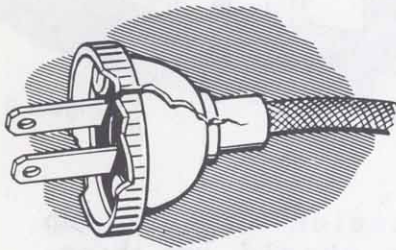

Figure 8

How Many Hazards Did You Find?

Make a chart listing the hazards, their locations and what you did about them. Make your own chart and list what you find.

Demonstrations You Can Give

Show and tell others how to have a Hazard Hunt.

For Further Information

Check with your leader, then ask your power supplier or a local electrician to tell you about safe electrical wiring, connections and fixtures.

Hazard	Location	What I Did
Loose prong on lamp plug	Living Room	Replaced with new plug
Cracked insulator on service wire in house	Back of house	Notified power supplier
Conduit not securely clamped to box	Basement by fuse box	Notified parents
Extension cord, old and worn	Basement, by washing machine	Replaced with new rubber-covered one and protected it from water



HOW ELECTRIC BELLS WORK—FOR YOU

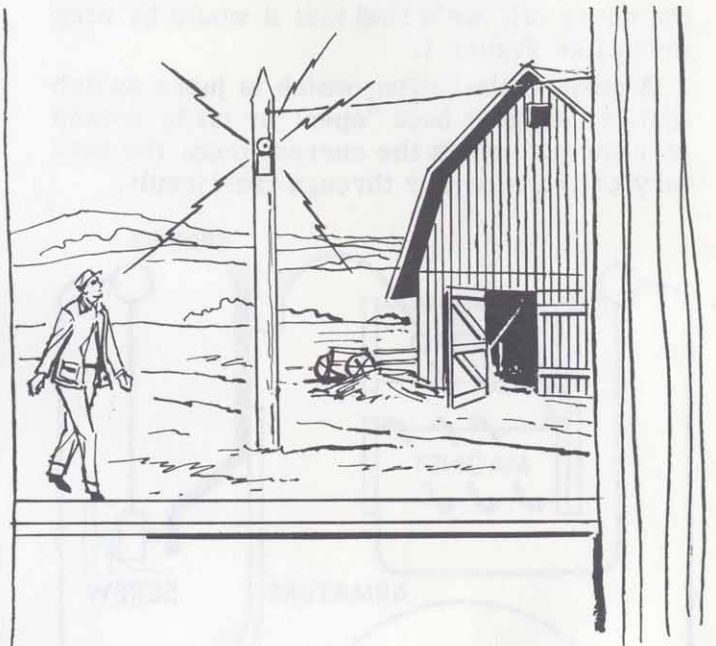

WHEN was the last time you wanted to get a simple message like "You're wanted on the telephone," "There's someone here to see you," or "There's a car in the driveway," to someone around your place? Did you have to walk or run some distance and perhaps shout, too, to be heard by the other person? Perhaps you had to stop some other work, or interrupt your favorite kind of fun, to do this bit of messenger work.

If the nature of the message is like one of those mentioned, and the number of people in hearing is not too great, then perhaps you can use bells or buzzers or both to do some of your messenger work for you. Even though a bell or a buzzer can't talk, it can convey a message.

What to Do

1. Learn how bells and buzzers work, and learn about the many different kinds.
2. Plan and install a bell system for your home or farm.

Bells and Buzzers Can Tell a Lot

Electric bells and buzzers use the same basic principle as the telegraph system, invented by Samuel Morse in 1840. Although

not as important today as it was before radio, telephone, and teletype became common, the telegraph is still in use.

Bells and buzzers, however, are very common and have many uses. They are most often seen in the form of doorbells, and rare is the new home that does not have one or more. Service stations have bell systems to let the operator know that a car is waiting at the gas pumps. A clock signal reminds the homemaker when the cooking time is completed. Children are called to and released from school classes by means of bells and buzzers.

Also, various alarms employing bells and buzzers warn us when it's time to get up, or even that the place is on fire, or that a burglar is trying to break in!

Let's find out how bells and buzzers work, what different kinds there are, the different ways you can control them, and how you can put them to work for you.

You'll find that buzzers and bells can help you with your 4-H projects, and with the proper controls, can be your eyes and voice in a dozen places at once.



Give your appliances and lights a square meal



Shrinking TV picture



Too much fuse blowing

Watch for
these signs
of starvation



Heating appliances slow



Lights dimming

Would you say that having enough to eat was pretty important in the home that you know?

The "food" for your appliances and lights is electricity, and like you they must be "fed" enough.

What to Do

1. List the appliances and lights in your home.
2. See if any of them are "starving" for the electricity they need.
3. Learn how the electricity gets to where it's used.
4. Make a chart of the electrical circuits in your home.

5. Make sure that each circuit is protected with the right fuse or circuit breaker.

Count Your Electrical Blessings

Many people in much of the rest of the world wish that they could trade places with us, because we have so many electrical appliances in our homes.

Of course, we have not always had as many appliances as there are today. When electricity first came along, people used it only for lights. Then, they began to add flatirons, washing machines, refrigerators, coffee percolators, and radios.

Then more and more electrical things were made for people to use and enjoy. Now we have dozens and dozens of uses for electricity in our homes.

How many different uses for electricity are there in your home today? Ask your parents how many there were when your home was built or first wired. How many were common when your parents began to keep house?

Some Homes Are Behind Times

Many older homes were built before electricity was available, and were wired later. And like them, some older homes that were wired as they were built had only enough wiring for lights and a few other appliances, because those were the only uses that were known at that time.



But people kept on living in these homes, and kept adding to the uses they made of electricity without adding to their wiring.

What has this meant? Well, if electricity were like cars and trucks, you could say that some people are trying to put turnpike traffic through a back-country dirt road!

Watch for Signs of Starvation

Of course, as your state has done with its highways, some people have expanded and modernized their wiring. But many others have not yet seen this need, or if they have, they may have to do it again.

Here's why:

Your power supplier delivers current to you at the right voltage or electrical pressure. If the wires in your house are large enough, they will pass this full voltage on to the appliances.

But if your wiring is too small, the electricity arrives at the appliances so weak that they can't work properly, and much of what you pay for is wasted.

Here are some things you can watch for in your own home. They will tell you whether your appliances are getting enough electrical "food" or not.

1. A shrinking TV picture--If it draws in from the sides of the screen, fades, loses contrast, or if the sound becomes distorted, you may have low voltage.

2. Too much fuse blowing or circuit breaker tripping.

3. Heating appliances are slow to do their jobs.

4. Lights dimming, when motors or other appliances are turned on.

There Should Be Enough Ways to Get "Appliance-Food" Around

If appliances in your home show these starvation signs, then you may not have enough ways for the electricity to get to where it's used.

There are three kinds of these electrical highways or circuits, and your home should have enough of each:





1. General purpose circuits--These serve lights all over the house, and convenience outlets everywhere except in the kitchen, laundry, and dining areas.

A rule-of-thumb is: There should be at least one general purpose circuit for each 500 sq. ft. of floor space.

2. Small appliance circuits--These are not used for lights, but instead they supply convenience outlets in the kitchen, laundry, and dining areas where portable appliances are most used.

Every home should have at least two small-appliance circuits.

3. Individual or special-purpose circuits--One of these is needed for each: electric range, dishwasher, water heater, freezer, automatic washer, clothes dryer, air conditioner, pump, and house heating equipment.

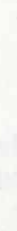
Actual Size					
Gauge Size	14	12	10	8	6
Fuse or Breaker	15	20	30	40	55
Max. Watts at 115 V.	1725	2300	3450	4600	6325
Max. Watts at 230 V.	3450	4600	6900	9200	12750

Wire sizes commonly used in homes

Each Circuit Big Enough

The capacity of each circuit is limited by the size of its wires. The chart above shows you the actual sizes of wires commonly used in permanent home wiring, and what each will carry. Notice that each size is given a number, and the smaller the number, the bigger the wire.

Also notice that a given size of wire will carry twice as many watts at 230 volts as it will at 115 volts. (Watts are figured by multiplying amps times volts.)

General purpose circuits usually are either Number 14 or Number 12 wire, at 115 volts. What is the capacity of each, in watts? (Number 12 wire is recommended for all new general purpose circuits.)

Small appliance circuits are required to be at least Number 12 wire.

Individual circuits are always sized according to the appliance they serve. Find the size wire that should be used for a 10,000-watt, 230-volt range; a 1500-watt, 115-volt dishwasher; a 4500-watt, 230-volt clothes dryer.

Only One Fuse Size Right

A fuse in an electrical circuit is like an alert traffic policeman--stopping everything if there's danger. A circuit breaker serves the same purpose, and the right size is installed when the wiring is done.

A policeman uses his brain to tell him when to blow his whistle, but a fuse depends on the size of the little fusible (meltable) metal link that you see under the glass.

If too great an electrical load is added to a circuit, this link will melt and prevent a dangerous overload. If you put in a fuse with too heavy a link, it will not melt in time, and the wiring and equipment may be damaged.

Therefore the right size of fuse is very important, and is something that you should check in your own home.

See the chart above for the right fuse for each size wire.

Make a Circuit Chart

At one or more places in your home there is a box or panel containing the fuses or breakers for the various circuits. Attached to the inside of the door of each such panel should be a chart something like this:

No.	Description	Fuse size
1	Range	40
2	Kitchen Outlets	20
3	Dining Room Outlets	20
4	Living Room Outlets	15

Notice that in our chart we have made columns for a description of what each circuit serves, its number or position in the panel, and the proper size fuse for it.

Because most such charts leave out this last very important bit of information, you should make a complete new chart, like the one shown. Provide as many lines as there are fuse positions. Paste or tape it to the inside of the panel door.

Then, ask permission of your parents to disconnect all the circuits by unscrewing the fuses or flipping the circuit breakers. Do not touch anything but the fuse rim. Then reconnect them, one at a time, to find out what each circuit serves. Turn on as many lights as you can, to help you in your detective work. Use a test lamp at those outlets that do not have a light connected to them. Write two or three words describing each circuit on the proper line on your chart.

On a separate sheet, keep track of the appliances and lights that are on each circuit, and add up the watts. (If the nameplate of any appliance gives "amperes", "amps", or "A" instead of watts, just remember that amps times volts equals watts.) This will tell you if any of them are overloaded. Show this sheet to your parents.

Check the Wire Sizes

Disconnect the main switch, and determine the size of the wires in each circuit. Don't include the insulation in your measurement.

BE CAREFUL!

Even though you have disconnected the main switch, the wires coming into it are still "live." So, do not touch any wires. Instead, hold the wire size chart near them so that you can tell which gauge each one is.

Write in the proper size fuse for each circuit on your chart.

Replace Any Wrong-Size Fuses

Do the fuse sizes you have written on your chart agree with the ones that are in place in the panel?

Get the right size fuses and replace any that are wrong. Make sure that you have a reserve supply of the right sizes, and that they are handy for future use.

Talk it Over With Your Parents

Do you think that your home has enough of the proper size circuits? If not, talk it

over with your parents. They may want to ask an electrician to go over the wiring and make the necessary changes.

What Did You Learn?

(Underline the right answer.)

1. A (television set, radio) is very sensitive to changes in voltage.
2. Dimming lights mean (static in the wires, an electrical overload).
3. Wires that become warm from overload make it (more expensive, cheaper) to operate the equipment.
4. A home of 2,000 sq. ft. should have at least (three, four) general purpose circuits.
5. One solution to low voltage symptoms is (heavier fuses, more circuits).
6. Full capacity for a Number 14 wire circuit at 115 volts is (1725 watts, 3000 watts).
7. A room air conditioner should be on (a general purpose, an individual) circuit.
8. The purpose of a fuse is to (let you disconnect the circuit, automatically prevent overloading the circuit).
9. The right size fuse is determined by (wire size, the store where you buy it).
10. A circuit chart should give (circuit description and fuse size, the maker's name).

Demonstrations You Can Give

Ask your leader to help you plan a demonstration. You can show how lights dim when too many other appliances are connected, how a fuse protects against overloading, and the danger of using too large a fuse.

For More Information

Ask your Extension agent, power supplier, or electrician for additional help.



YOU CAN MEASURE ELECTRICITY



Instruments that can detect or measure the flow of electricity have helped to make possible the wonders of electricity as we know them today.

Scientists in laboratories must have measuring devices for experiments leading to new uses of electricity. Power suppliers must have instruments that tell what the generating equipment is doing and to measure the amount of electricity being sold to users. Factories need instruments that keep tab on electrical equipment to make sure electricity is being used efficiently.

In fact, almost anywhere you find electric power at work you'll find electrical instruments--even in your home. The one you know best measures the amount of electricity used. Another, in the family car, shows whether the generator is charging the battery or if the battery is discharging.

What to Do

1. Make a simple kind of direct-current meter that will show you that there's a mag-

netic field around a wire carrying an electric current and that will detect a very tiny current.

2. Make a more refined D. C. instrument (galvanoscope) and measure the voltage of different sizes of dry batteries, and show how an electric current can be induced.

Tools and Materials You'll Need:

Pair of pliers, knife, small hammer
30 feet of No. 24 bell or magnet wire
Compass
Two coins — a penny and a dime
Fine sandpaper
Blotting paper
Plastic or cellophane tape
Wooden blocks (See Figure 4)
Glue
2 small nails
One #905 dry cell, a penlight battery, and two regular flashlight batteries
Table salt
Drinking glass
2 paper clips
Two machine bolts

How They Work

Like many electrical things, most electrical instruments depend on the action of magnetism created by an electric current. There is a magnetic field or lines of force around any wire carrying an electric current. If this field is controlled and made to react on a sensitive device, like an easily moved pointer, we have an electrical instrument.

Detect a Magnetic Field

First, let's prove that there is a magnetic field around any wire carrying an electric current. Take a piece of wire about two feet long and scrape off about an inch of insulation from each end. Connect one end to a battery terminal. Make a loop of wire that crosses the face of your compass, north to south. Now touch the other end of the wire to the other battery terminal.

→ → (DO NOT attempt to substitute alternating current, as from a model railroad transformer because its alternating current will cause the compass needle to swing rapidly from one side to the other.)

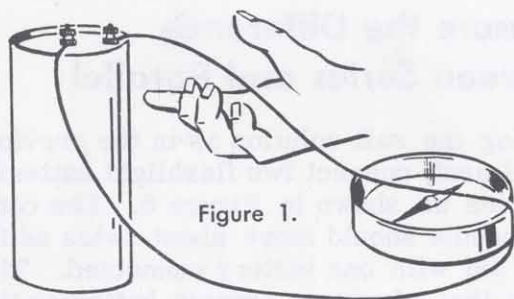

Figure 1.

Put your right hand beneath the wire so that your fingers point the way the needle deflects, and your thumb will point in the direction that the current is flowing.

What happens? Your compass needle should move to one side because it is very sensitive to magnetic influences. This proved that the wire created a magnetic field or lines of force when we passed electricity through it. (Figure 1)

Detect a Tiny Current

How sensitive is your simple electric meter? Take about five feet of wire and

wrap it around your compass as in Figure 2, keeping the turns bunched together as much as you can. Leave about six inches at both ends of the wire extended for leads. Scrape the insulation off the last inch of both. Rotate the coil and compass until the needle and coil are parallel, both pointing north and south.



Figure 2

Take a copper penny and a dime, and clean off any corrosion or film on the coin faces with a bit of fine sandpaper. Now take a piece of blotting paper about the size of the penny and dip it into strong salt water. Place the damp blotting paper between the penny and the dime. Place one of your compass coil leads against the dime, and the other against the penny as shown in Figure 3. Be sure you have good metal-to-metal contact between the wires and the coins.

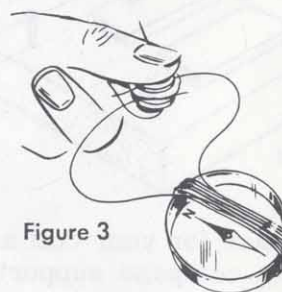

Figure 3

At the instant that you squeeze the leads against the coins, watch what is happening to the compass needle. It should move for an instant from the north position each time you press the leads against the two coins.

Obviously, the little coin battery you have just made produces a very weak electrical current. Even so, your instrument should be able to detect it.

Make a Simple Galvanoscope

Now let's make a meter that is a little more practical to use. Broadly speaking, a galvanoscope is an instrument that detects the presence of electric currents. It sounds complicated but it is really quite simple. It is named in honor of an Italian professor named Galvani who made important early experiments with electricity.

A refinement of the galvanoscope is today's galvanometer. Other related instruments are the voltmeter and ammeter. These are very important instruments to the electrical engineer.

Using a glass or anything three to four inches in diameter, wind about 20 turns of wire in a "bunched" coil as in Figure 4. Wrap the coil at several points with cellophane or plastic tape to keep it from unwinding.

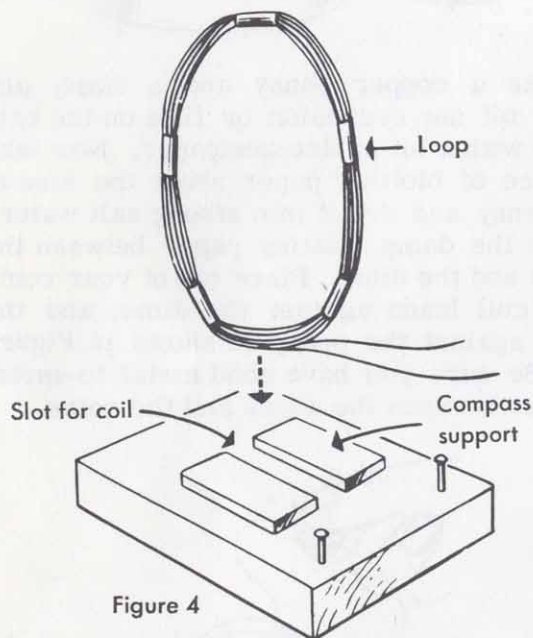

Figure 4

Make a wood base for your coil as shown in Figure 4. The compass support blocks can be thin wood slats. Do not attach them with steel nails or tacks. Use glue instead. Hold the coil in the slot between the blocks with glue or melted wax or use copper staples. Place the compass on the supports and rotate the base so that the compass needle and coil are parallel, pointing north and south.

Measure the Voltage of Batteries

Do you know what difference the size of dry cell battery makes in the voltage it supplies? Your meter can tell you.

To test the voltage of batteries we must be able to control our galvanoscope. To do this, connect a glass of strong salt water in series with the battery as shown in Figure 5. Make sure the wire ends immersed in the salt water are scraped free of enamel.

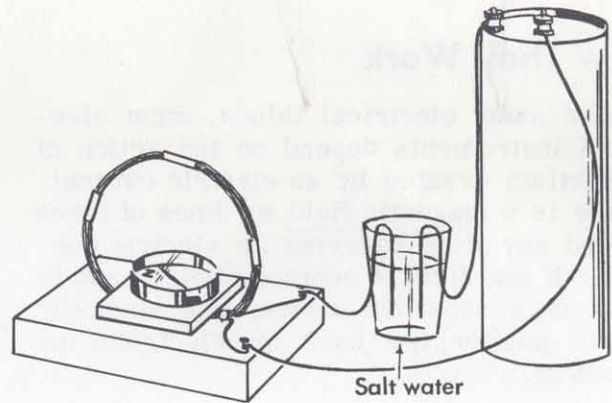

Figure 5

With one of the batteries connected, move the wires in the salt water first closer, then farther apart (keeping them parallel to each other) while watching your compass needle. When the needle stays 15 to 20 degrees off north, lock the wires in the salt solution in place with paper clips.

Now disconnect the battery you have been using and connect a smaller battery. If both batteries are fresh, the compass needle should return to almost the same spot. This proves that both batteries regardless of size put out the very same voltage. The larger ones, however, are designed to last longer.

Measure the Difference between Series and Parallel

Using the salt solution as in the previous experiment, connect two flashlight batteries in series as shown in Figure 6. The compass needle should move about twice as far as it did with one battery connected. This shows that when you connect batteries this way you double their voltage.

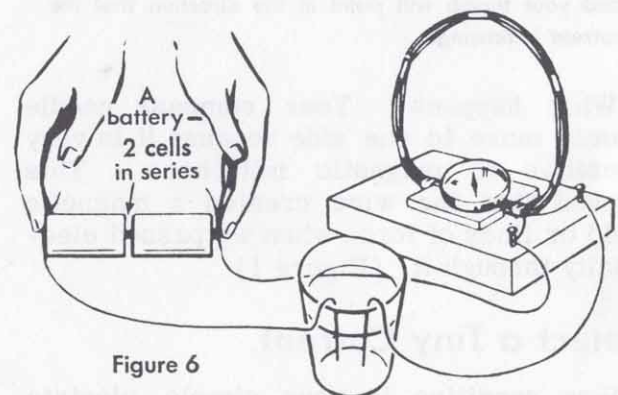

Figure 6

Now place your batteries side by side and connect the two top terminals and the two bases as shown in Figure 7. The compass needle should move only as much as it did for one battery. This is called a parallel connection. You can see that this arrangement does not double the voltage, even though you used two batteries.

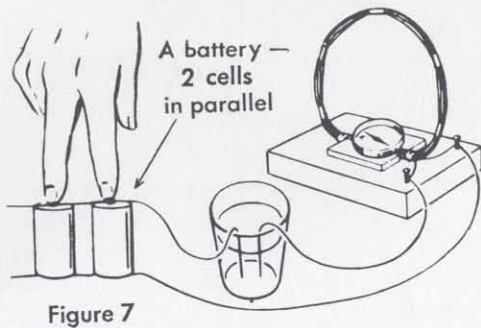

Figure 7

While you have this hook-up, try reversing the position of the leads connected to your batteries. Notice that reversing the direction of current flow in the coil causes the compass needle to swing in the opposite direction.

Test for Induced Current

Make a simple coil by winding about 50 turns of wire around a machine bolt core. The bolt should be $1/4$ to $1/2$ " in diameter and about two inches long. Connect the coil to your galvanoscope as shown in Figure 8. Pass the coil back and forth close to the end of a permanent magnet.

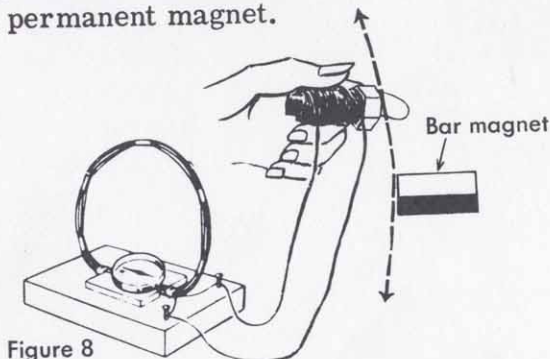

Figure 8

Notice a slight deflection of the compass needle with each pass. You have shown that electricity can be induced in a wire coil by moving it through a magnetic field. Currents generated in this way are called induced currents.

Now make another coil and core just like the first one and arrange them and a con-

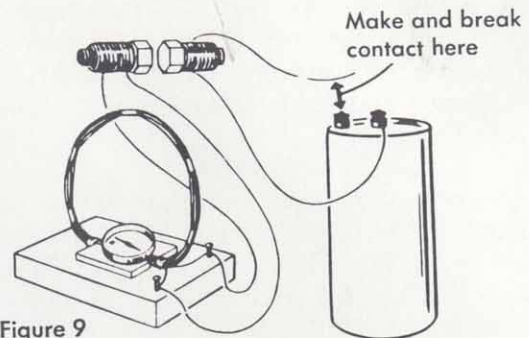

Figure 9

nection as shown in Figure 9. If you make and break the current to the second coil, you will build up and collapse a magnetic field around the first coil and again induce a current in it. You will see the compass needle swing back and forth again.

These last two experiments give you a crude idea of how an electric generator works, producing electric current by induction as a coil-wound rotor revolves within a magnetic field.

What Did You Learn?

What does every current-carrying wire have around it? How does this help us to measure electricity? How sensitive are electrical instruments? What is the difference in voltage between (a) a large and a small dry cell? (b) batteries connected in series and in parallel? (c) your original connection and the reverse of it? What similarity does the test for induced current show between movement through a magnetic field and the making and breaking of a direct current?

Demonstrations You Can Give

Show others how your galvanoscope can detect: whether a battery is producing current, which way the current is flowing, and whether a current is strong or weak. Demonstrate how a current can be generated using magnetism.

For More Information

Ask your power supplier representative to show you some of the instruments used by his organization, and to give you a brief explanation of how they work. Ask him or an electrician to give you a demonstration of a split-core ammeter.

Why They Buzz or Ring - - Electromagnetism

If we were to look at an electric bell with the cover off, we'd find that it would be very much like Figure 1.

A push on the button, which is just a switch that is normally held "open" or off by means of a spring, sends the current from the battery or transformer through the circuit.

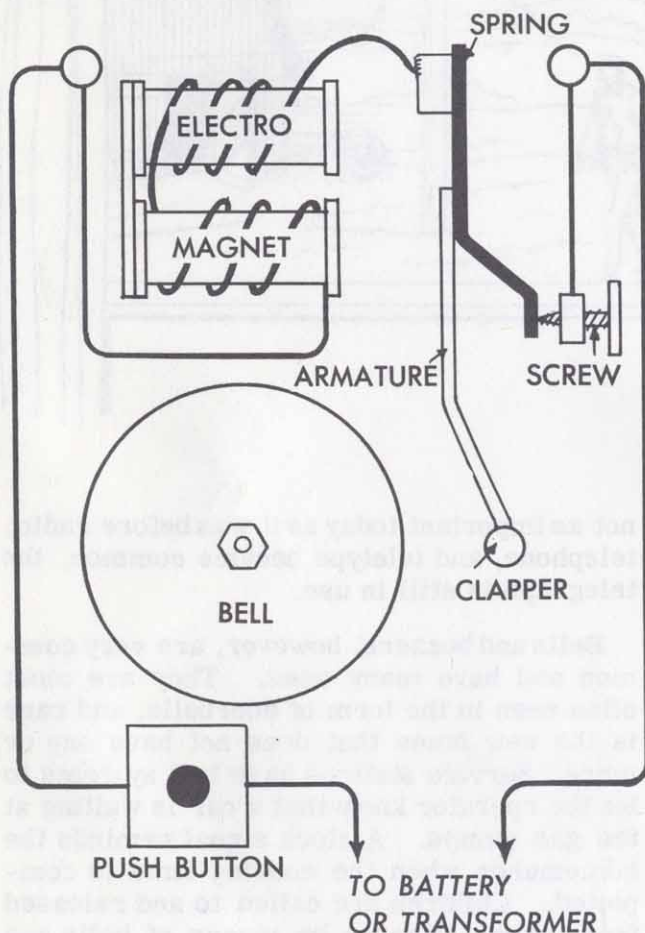

Figure 1

You will see that the current passes first through two small coils of wire, and each coil has at its center a piece of soft iron called the core. When the current is on, the core becomes magnetized and attracts another piece of iron called the armature with its clapper attached.

This action rings the bell, but it also breaks the current by pulling the spring away from the screw on its return to the power supply.

With the power off, the electromagnet lets the spring return the armature to its normal position, contact is made again, and the cycle starts all over again--just as long as you continue to push on the button.

Buzzers work exactly the same way, except that they do not have a bell and depend instead on the vibration of the armature for a noise that's not as loud or as musical.

Gongs or chimes, that strike only once when the button is pushed, are made by connecting the armature with the screw by means of a flexible wire.

A Special Kind of Electricity

Most buzzers and bells work on a much lower voltage than you normally find in the wires in your house. Some are made to work at 6 volts, others at 10 volts, and still others at slightly higher voltages.

You can get these low voltages by using one or more batteries, or by using a transformer connected to your house current. Most bells and buzzers are now powered through transformers.

How to Control Them

The push button is the most common means of control. You can use one button to control several bells, or several buttons to control one bell, or have several buttons control several bells. Because low voltage is used, adding extra buttons is simple, inexpensive, and safe.

Buzzers and bells can also be controlled by: clocks, as in the interval timer on an electric range or in a school class bell system; temperature detectors, as in a fire alarm or freezer alarm; door and window trips, as in a one-man repair shop or in a burglar alarm; and treadles, as in the driveway of a service station.

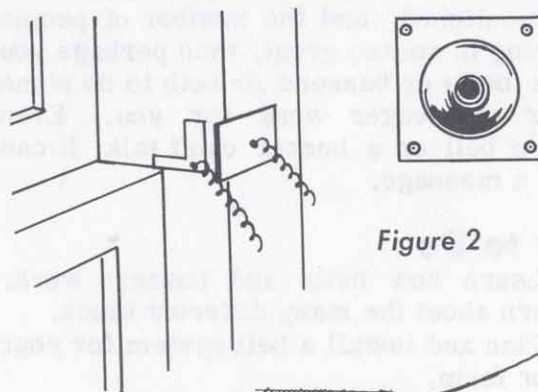

Figure 2

Pick the Right Bell or Buzzer

Some of the many different types of bells, and various ways of controlling them are suggested in the table below. Just remember

that no matter what the job or conditions, you can probably find a bell or buzzer and controls that suit your need.

SOME TYPICAL JOBS FOR BELLS & BUZZERS

Job	Type of bell or buzzer	Number and location of bells and buzzers	Type of control	Number and location of controls
Summon others to the telephone	In the house— small to medium buzzers In outbuildings— medium to large bells Outdoors large weatherproof bell All transformer-powered	Enough to cover all usual work locations	Push-buttons	One at the telephone and each extension phone
Notify club member that car is at his produce stand	Medium to large bell— transformer-powered	One may be enough— if mounted on the back of the stand	Hose-diaphragm	One—in the driveway (Complete driveway units, including control, are available, ready to plug in)
Warn of power failure to incubator or brooder	Battery-powered buzzer, medium size	One near the poultryman's bedroom	Relay, held open as long as power is on, closed by spring if interruption occurs	One, at main switch of hatchery or brooder house
Warn of dangerously warm temperature in freezer	Battery-powered buzzer, medium size	One, in or near the kitchen	Temperature detector (sensitive thermostat)	One, with bulb inside freezer

How to Plan Your System

To save your time and steps when the telephone rings for someone else in your family who is some distance away, you can install a simple bell or buzzer system to summon that person.

First, you must plan what you are going to do. On a large sheet of paper, draw to scale (roughly) a plan of your house and grounds, including those places where phones are located. It will help if you rule off your paper in 1/8" or 1/4" squares and let each square equal one foot. Show the location of poles supporting your wiring.

Next, pick out those areas where you or others would likely be when someone else would answer the phone and want to call you to it.

After you have thought about this, and

talked it over with members of your family, show locations on your plan where you think you would like to have buzzers or bells, and show a button beside each telephone. (Generally, you should have a bell or buzzer near each phone, also.)

Figure 3 shows diagrams of various types of systems, and will help you determine the number of wires you will have to install to connect the buttons and bells that you have planned.

Inside, you will connect your transformer and the various buttons and bells with ordinary indoor bell wire. Outdoors, however, you should use weatherproof 2-wire or 3-wire telephone twist.

Show on your plan the distances that must be traversed by each type of wire, and show the number of conductors in each. Don't overlook the vertical distances (one floor to another).

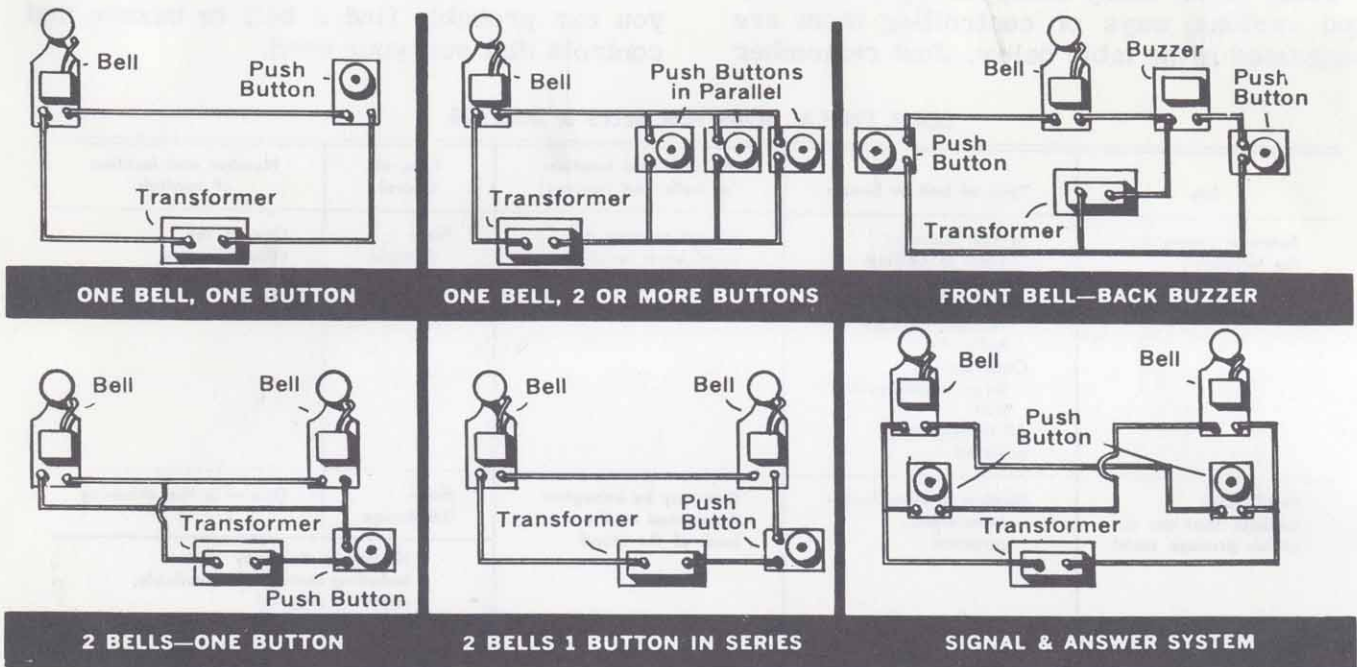

Figure 3

Materials You'll Need

Because no two situations are just alike, it will be necessary for you to make your own list of materials.

As a guide, however, here is a list of typical materials, with the quantities left blank, for you to fill in as your own requirements and measurements dictate.

- _____ 10-volt transformer
- _____ Door buzzers
- _____ Doorbells
- _____ Weatherproof outdoor type bells
- _____ ft. indoor bell wire
- _____ ft. 2-wire weatherproof telephone twist
- _____ ft. 3-wire weatherproof telephone twist
- _____ lbs. staples (insulated)
- _____ entrance insulators (for attaching weatherproof to buildings and poles)

Because your transformer must be wired into your regular house current, you should have some help on this from an electrician or other qualified person. Also, you should get that person to review your plans and materials list before you place an order.

Install According to Your Plan

With the aid of an electrician or other qualified person, install your transformer, and test it.

You may then go ahead and complete your signal system, checking carefully with your plan, and making sure that your installations are both electrically and mechanically secure.

Test your system in all possible ways that it might be used.

Demonstrations You Can Give

Build a demonstration board incorporating a farm or home layout, with pushbuttons or other controls and bells and buzzers appropriately located. Show and tell how the system would save time and energy.

Show and tell how some of these work, and their value: power-off alarm, freezer alarm, fire alarm, driveway alarm.

For More Information

Ask your power supplier or your nearest electrical supply house for catalogs or literature on various types of signal systems, or ask a dealer to show you equipment he has in stock.



FIRST AID FOR ELECTRICAL INJURIES



What would you do if you saw someone who had been hurt by electricity?

Did you know that you could save his life, if you had taken the time to learn and practice a few simple rules of electrical first aid?

First aid training equips you to know what to do and what not to do for the injured until medical help can be obtained. While the main benefits are for you and your family, no one can call himself a good citizen if he fails to help a stranger who has been hurt.

The information given here is only for electrical injuries. Perhaps what you learn will inspire you to take a complete course in first aid.

What to Do

Learn how to prevent electrical accidents, and what to do if an electrical accident occurs.

1. Make an electrical hazard hunt in your home or on your farm. Point out to your

parents everything that should be repaired or replaced for safety's sake.

2. Read the first aid suggestions that follow. Learn them.

3. Get to know the six steps that are outlined for mouth-to-mouth rescue breathing. Practice them on your brother, sister, or parents. Teach the entire family how to do it.

Electricity Can Kill

In this day of hundreds of uses of electricity, you should know about electrical dangers. Electrocutation can occur from either low voltage (household type) or high voltage currents. Sometimes household voltages are more hazardous because people underestimate the dangers involved.

A fraction of an ampere passing through your heart muscles can be fatal. Your body offers some resistance to the flow of electricity to ground. If you are standing on wet ground or in water, or if your skin is damp, this resistance is greatly reduced.

Wire cables within walls and cords on appliances are all insulated with a shock proof covering. Continued use, age, or damage may expose a bare wire and create a hazard. The point of exposure need be only a fraction of an inch. Cords are often used and abused. Exposed wires and signs of wear are danger signals.

Always be wary of overhead wires. People have been injured or killed when kite strings, model plane control lines, irrigation pipe, and water well equipment have come in contact with the power supplier's or their own overhead wiring.

Prevent Accidents

Underwriters' Laboratories (UL) have taken steps to see that minimum safety standards are met in the manufacture of electrical equipment. Look for the UL label when you buy cords or appliances. Never place cords under carpets or furniture, or drape them over a nail. Replace or repair worn cords without delay.



Be especially careful when operating electric devices in the bathroom. Keep in mind the dangers of a wet floor, grounded metal pipes, and wet skin. Turning on an AC radio while you are taking a bath is asking for real trouble.

There may be shorts in electric devices. Keep your hands dry when using them, and do not touch them along with grounded metal objects. If you ever get a slight shock, sound the danger signal and do something about it.

Think, Then Act

Your first thought in rescuing a victim from an electrical accident should be your own safety. Speed is also important, because a few seconds or minutes may save a life.

The first question you should ask yourself is "Can I quickly turn off the power?" This would be easier to do in the home than outside. In the case of a victim trapped in a bathtub from a radio accidentally knocked into the water, it might mean simply removing the plug from the wall outlet. If a victim is found grasping shorted, permanently installed equipment and cannot let go, the main switch might be used for quick release of the current.



Outdoors, especially with high tension wires, your danger in rescue is much greater. To handle the victim, touch him only with a long dry stick, dry rope, or a long length of dry cloth. Be sure your hands are dry and that you are standing on a dry board. A broom might be a good lever to pry a victim from a high tension wire but never use a green stick containing sap.



First Aid

Once the rescue has been made and the victim is free of further danger, check to see if breathing has stopped. If so, start artificial respiration immediately and send someone for a doctor.

Artificial respiration must be started as soon as possible after normal breathing ceases. Most persons will die within 6 minutes or less if breathing stops completely unless they are given artificial respiration. Precious minutes may have passed before you get to the victim. Since the victim may be within seconds of death by the time you are able to touch his body, you should seek to obtain an air flow to and from the lungs immediately.

The victim may seem stiff as an effect of the current, so don't give up easily. Continue the procedure for several hours. If transportation is necessary, remember that there may be internal injury, fractures, or severe burns.

Mouth-To-Mouth Rescue Breathing

There are various effective ways to give artificial respiration, each with its advantages and disadvantages. The mouth-to-mouth method is recommended as a good one to master. It can be used on victims of drowning, suffocation, and asphyxiation, too. People have been known to save lives with less exposure to the correct procedure than you are getting by reading this. So, pay attention and remember what you read.

Step 1. Turn the victim on his back. Wipe out victim's mouth quickly. Turn his head to the side. Use your fingers to get rid of mucus, food, sand, and other matter.



Head Position

Step 2. Straighten victim's head and tilt back so that chin points up. Push or pull his jaw up into jutting out position to keep his tongue from blocking air passage. This position is essential for keeping the air passage open throughout the procedure.



Push Jaw Up



Pinch Nostrils

Step 3. Take a deep breath, place your mouth tightly over victim's mouth, and pinch nostrils closed to prevent air leakage. For a baby, cover both nose and mouth tightly with your mouth. (Breathing through handkerchief or cloth placed over victim's mouth or nose will not greatly affect the exchange of air.)



Breathe

Step 4. Breathe into victim's mouth or nose until you see his chest rise. (Air may be blown through victim's teeth, even though they may be clenched.)

Step 5. Remove your mouth and listen for the sound of returning air. If there is no air exchange, recheck jaw and head position. If you still do not get air exchange, turn victim on side and slap him on back between shoulder blades to dislodge matter that may be in throat. Again, wipe his mouth to remove foreign matter.

Step 6. Repeat breathing, removing mouth each time to allow air to escape. For an adult, breathe about 12 times per minute. For a child, take relatively shallow breaths, about 20 per minute. Continue until victim breathes for himself.

What Did You Learn? True or False

1. A broken arm should be splinted before artificial respiration is applied to a victim who is not breathing.
2. A person who has been severely shocked with an electric current should lie down.
3. A doctor should be called even though you successfully have revived a victim's breathing.
4. A fraction of an ampere through the human heart muscles can be fatal.
5. A copper wire would provide a better path than your body for stray currents, therefore all appliances should be grounded if possible.
6. Outside wires are never a hazard because they are covered with insulation when they are installed.

7. Cords need not be repaired until you can see bare wires.
8. Tuning in an AC radio while you are bathing is always dangerous, even though your hands are dry.
9. In an emergency, a broom is an acceptable tool for prying a victim off a high tension wire.
10. In mouth-to-mouth breathing, an adult's lungs should be filled 12 times per minute and a child's 20.

Demonstrations You Can Give

Show how to deal with an electrical first aid "problem" given to you by your leader.

For More Information

Ask your leader to have a first aid expert put on a demonstration. (Many industrial plants and power suppliers have such people.)



Mouth-to-Mouth Breathing

There are several effective ways to give artificial respiration. Each with its own special advantages. The mouth-to-mouth method is recommended as a good one to master. It can be used in various situations and conditions and gives the best results. People have been known to give their own life through this method. It is a simple and effective way to give artificial respiration. It is a simple and effective way to give artificial respiration. It is a simple and effective way to give artificial respiration.

Step 1. Turn the victim on his back. Wipe out victim's mouth carefully. Turn his head to the side. Use your fingers to get the air out of his mouth and other nostrils.





HOW ELECTRICITY HEATS

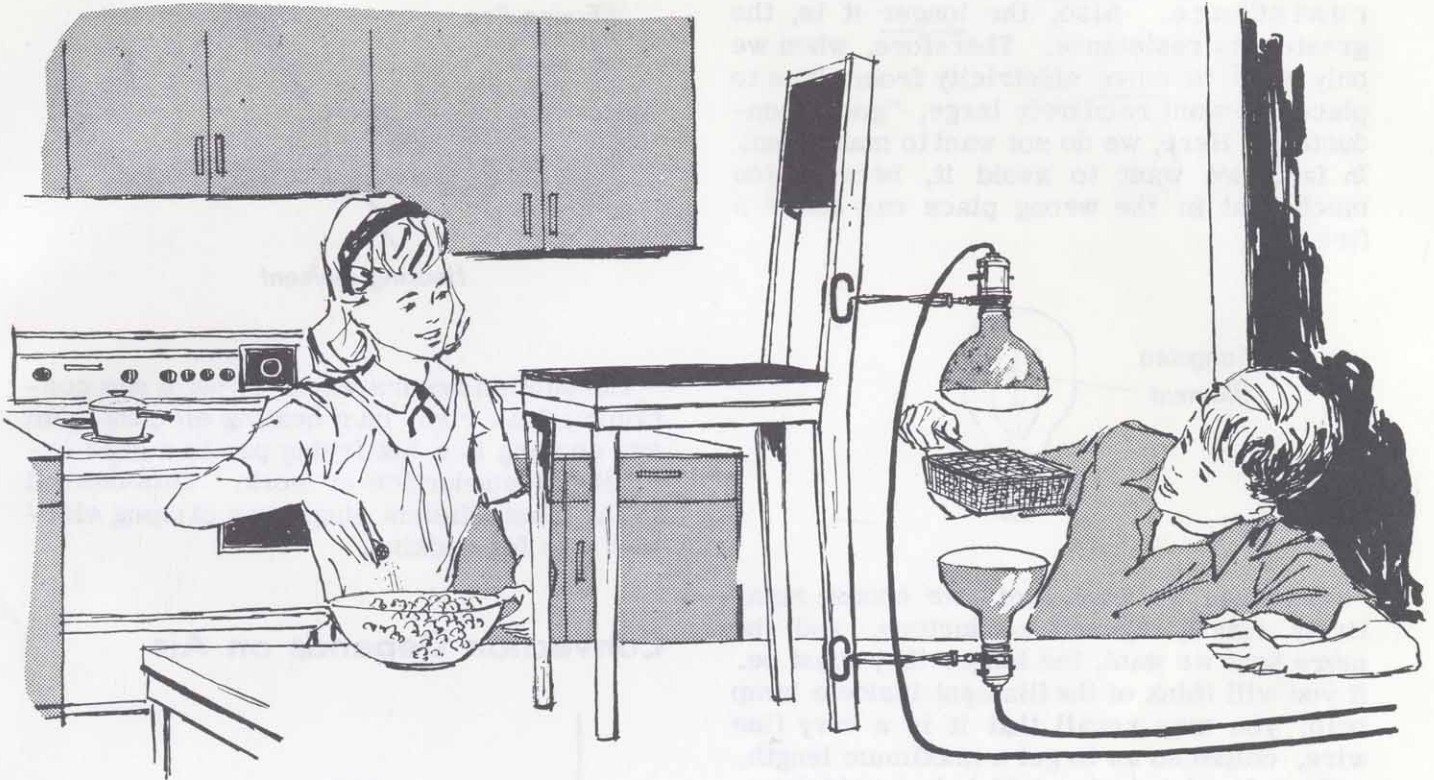

In ancient times, people thought that heat was a material just as air is. They called it "caloric". When something got warm, they said, caloric flowed into it. When something cooled off, caloric flowed out of it. It did not bother them that they could not see caloric. They could not see air either!

Now we know that heat is not a material. It does not take up space. It does not weigh anything. Instead, it is a form of energy. And when we say that heat is a form of energy, we mean that it can be used to do work.

What to Do

1. Make a simple resistance heater.
2. Make some popcorn by:
 - (a) conduction
 - (b) convection
 - (c) radiation

"Resistance" Makes Heat

There are at least four ways that elec-

tricity can make heat. The one that we'll cover here is resistance heating. (The others are: dielectric heating, where the lines of force of an electrostatic field pass through a non-conductive material and heat it; the heat pump, which is a refrigerator in reverse; and electronic heating, which uses high frequency waves similar to radio waves to create high speed movement of the molecules or tiny particles which rub together to make heat.)

Resistance heating occurs because every conductor of electricity opposes the flow of current through it. Some conductors resist more than others. When they do, a certain amount of warming takes place. The more resistance that is offered, the more heating there is.

Some materials, like silver, copper, and aluminum, offer little resistance. We say they are good conductors.

Other materials, like iron, offer more resistance. They are still conductors, but not as good as the others mentioned.

The size of the conductor, and its length are the other two things that affect its resistance. The smaller it is, the greater its resistance. Also, the longer it is, the greater its resistance. Therefore, when we only want to move electricity from place to place, we want relatively large, "good" conductors. Here, we do not want to make heat. In fact, we want to avoid it, because too much heat in the wrong place can cause a fire.

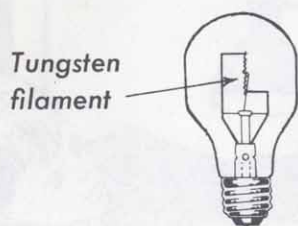

But when we want heat, we choose relatively small, "poor" conductors, and the more heat we want, the longer they must be. If you will think of the filament inside a lamp bulb; you may recall that it is a very fine wire, coiled so as to get a maximum length, and made of tungsten which has a high resistance.

Because of all these factors, this filament glows at a white heat, and is a source of both light and heat.

Make a Simple Resistance Heater

Materials you will need:

- 1 dry cell battery
- 1 foot iron picture wire
- Pliers

Use a short strand of iron picture wire and hook the ends to the terminals of a dry cell battery. Use pliers so that you do not burn your fingers. Disconnect the wires as soon as they become hot. Tell why the wires heat.

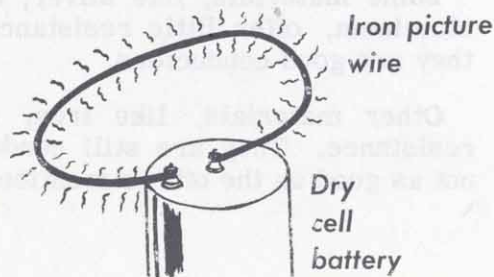

Conduction is "Touching" Heat

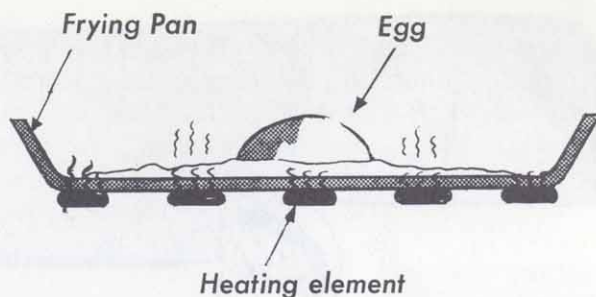

Conduction occurs when you set a pan containing food right on a heating element. An egg cooking in a hot frying pan is a good example of conduction at work. This method is the most efficient single way of using electric heat for cooking.

Convection Depends on Air

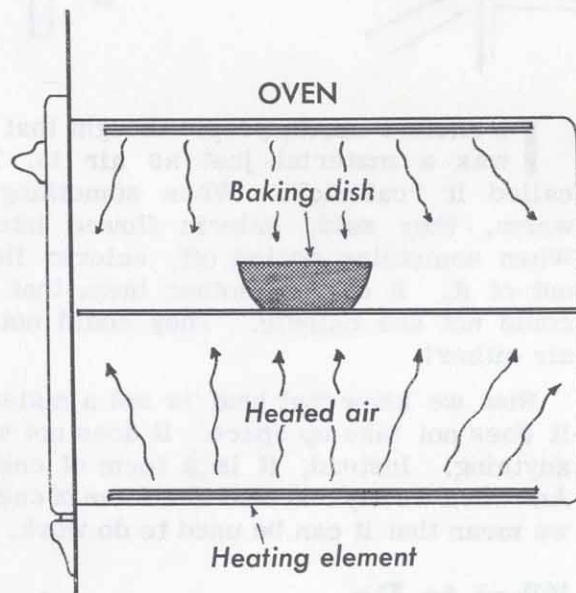

Convection warms food in pans that are not actually touching the heating element. It uses the hot air around the element to carry heat to the pan.

Your oven in your range works by convection. Most houses are warmed in winter in the same way. The heat produced in a furnace warms the air as it circulates through. This air in turn keeps your body warm.

Radiation is Like the Sun

Radiation heating is more difficult to explain. It results when heat or energy waves strike an object and are converted into heat. The energy we receive from the sun is a good example. When you are wearing dark clothes on a chilly day, you may become uncomfortably hot. The sunshine warms you even though the air around you has not been heated. Radiant energy has a way of being absorbed by dark objects and reflected by light colored or shiny surfaces. Did you ever notice how snow melts faster on a black top road than it does on a concrete road?

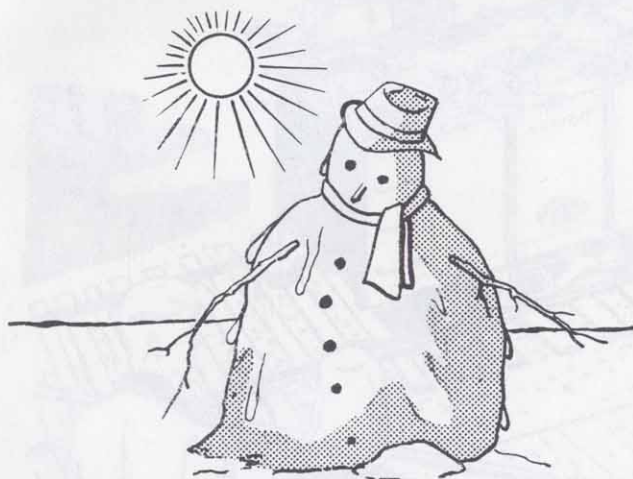

The electric heat lamp is one of the most familiar sources of radiant heat. Other examples are panels and cables that are built into the walls and ceilings of homes to provide heat.

Make Popcorn 3 Ways

How do you make popcorn? Did you know that you can do this kind of a heating job three different ways?

Materials Needed

Popcorn
Cooking oil or shortening
Salt and butter
4-qt. saucepan, with cover. (A glass cover is preferred.)
Potholder
Electric range
2 250-watt heatlamps
2 spring clamp type lampholders
Wire mesh corn popping basket or wire mesh kitchen strainer (improvise a screen wire cover)

First, make popcorn the way you usually do. Set a front surface unit control on the range at "medium high". Pour enough oil to very lightly cover the bottom of the pan. When the pan is hot, pour in enough popcorn to cover the bottom with one layer of kernels. Use the potholder in one hand to hold the cover on, and with the other move the pan back and forth across the unit. When the popping stops, remove from the heat.

How did the heat get to the popcorn?

Second, make popcorn in the oven. Add the oil to the pan, cover it and put it in the oven. Turn the oven on, with the automatic control set at 400°. When the oven indicator light goes off, this means that the proper temperature has been reached. With the potholder, remove the pan and add one layer of popcorn kernels. Replace the pan in the oven. When the popping stops (listen for it) remove the pan.

What kind of heating took place here?

Third, make popcorn with the heat lamps. Clamp the lampholders to the back of a chair or other vertical support. They should be 6 to 8 inches apart and pointed directly at each other. Put about 2 tablespoonfuls of popcorn in the wire basket or strainer. Do not add oil. Hold the basket midway between the two lamps. When the popping stops, turn off the lamps.

What kind of heating was this?

Now, butter and salt the popcorn you have made and share it with others.

What Did You Learn?

1. How is heat transferred from one body to another?
2. Could chicks or pigs receive warmth from a heat lamp without the air in the pens becoming warm? Explain.
3. How does a broiler unit in a range cook meat?
4. How does an oven bake food?
5. Tell why iron picture wire was used instead of copper wire for your heating demonstration.



MYSTERIOUS MAGNETISM



In ancient times, people found certain rocks that clung together in bunches. These rocks were very mysterious. People didn't understand them and many superstitions grew up about lodestones, as these rocks were called. Lodestone (sometimes spelled loadstone) means leading stone. People even told Columbus not to sail out of sight of land because a giant lodestone was just over the horizon waiting to pull all the nails out of his ships.

The Chinese were the first to use magnets. They found that if you hung a lodestone by a string, one end of the stone would always point in the direction of the North Star. They had the first magnetic compasses.

An artificial magnet can be made by stroking or gently rubbing a piece of steel with a lodestone. This piece of steel then can be used to magnetize another piece of steel. This can be continued on and on. Lodestones are not always available but you can get the same results with an electric current. So, magnetism and electricity are very closely related.

What to Do

Learn about magnetism by doing the experiments that follow.

Seeing is believing!

Materials You Will Need

2 dry cell batteries (#905)
A few feet of No. 18 bell wire
3 steel knitting needles or similar hard steel
2 ft. of light thread
Sheet of light cardboard or stiff paper
Permanent magnet (bar or horseshoe)
Compass
1 or more large nails or spikes
Red and black china-marking pencils or crayons

Iron filings Wire cutters Carpet tacks

(Iron filings usually can be found under the grinding wheel in a shop. If you can't find

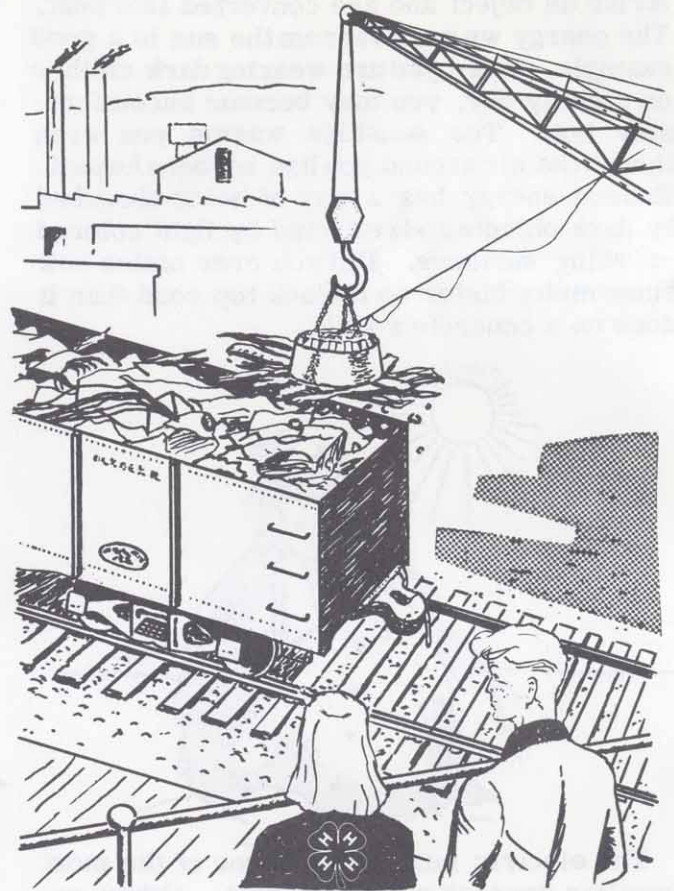

any, rub some steel wool pads together to produce bits of metal that will do.)

"See" a Magnetic Field

Cover the permanent magnet with the cardboard or paper. Sprinkle iron filings on the paper. Tap the paper and note the pattern formed. Strings or lines of filings pass from one pole of the magnet to the other. The area covered by the filings is the center of the magnetic field. To remember this, you might compare the magnetic lines of force that arrange the iron filings to the contour strips in a farmer's field.

This magnetic field is one of the important things in our everyday life with electricity. If it were not for the magnetic field, we would not have electric motors. Telephones, radios, television, and many other things we use every day also depend on this magnetic field.

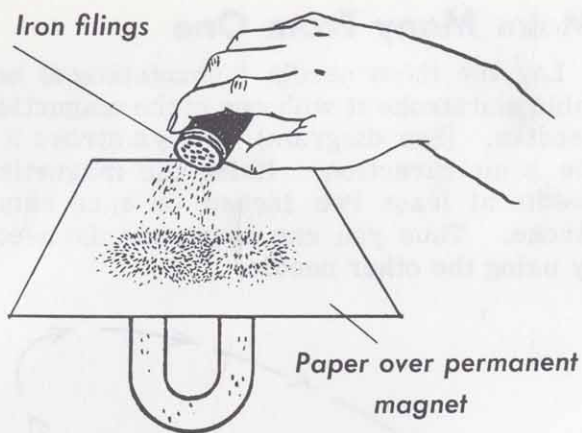

Figure 1

Make an Electro-Magnet

You can make magnetism work for you by winding several turns of insulated wire around one or more large nails or spikes (soft iron). Connect one end of the wire to the battery. Touch the other end of the wire to the other terminal for a few seconds and see how many tacks you can pick up. Repeat the experiment using as many turns as possible. How many more tacks were you able to pick up?

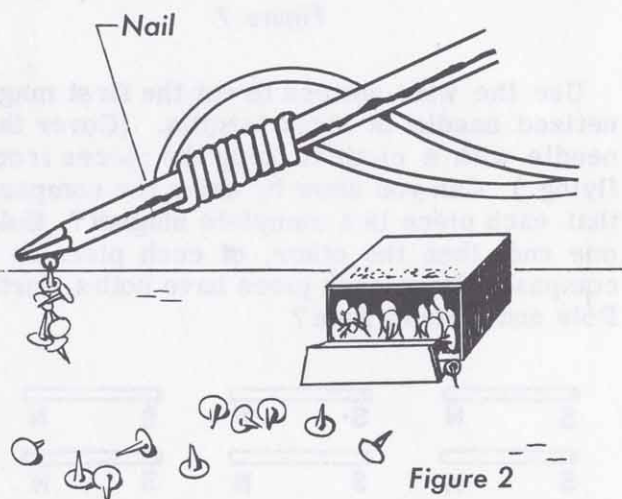

Figure 2

You have made what we call an electro-magnet. When you disconnect the wire, the nails fall off. This is one of the advantages of an electromagnet. We can turn magnetism on and off as we wish. Picture a crane operator throwing the switch and picking up scrap iron and steel. Then he opens the switch to drop the scrap metals.

Soft iron can be magnetized easily as you have just seen, but loses its magnetism in a short time. Steel is harder to magnetize but holds its magnetism almost indefinitely.

Make a Permanent Magnet

Wrap the insulated bell wire around the steel knitting needle. The wire should be wrapped the full length of the needle. One end of the wire is connected to the battery. The other end of the wire is then touched for just a few seconds to the other terminal. This should make the needle into a permanent bar magnet. If you did not get results, try two batteries in series, wind more turns of wire on the needle, and leave it connected a little longer. Do the same thing with the second knitting needle. In the same way, you can magnetize a screwdriver, so that you can use it to pick up and hold steel screws. Don't do it unless you want your screwdriver to be magnetized.

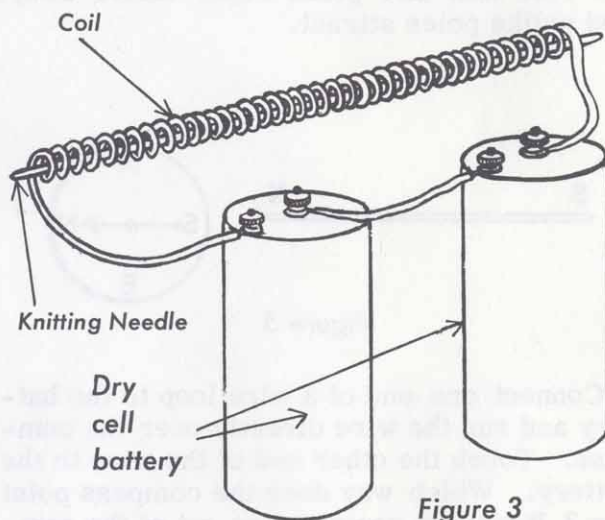

Figure 3

See How They Attract and Repel

Take one of the magnetized needles and hang it with a thread. A thread stirrup (Figure 4) will help keep it level. Be sure it is not near other large pieces of steel. Watch the needle. Does it settle down, pointing in one direction? (Check to see if this is the same direction as your compass). If it does, you have made a compass. The tip of the needle pointing north is called the North Pole (North-seeking pole). The other end is called the South Pole. Mark the North Pole with a stroke of the red marking pencil. Mark the South Pole black. Do the same thing with the second needle. You can show this with a sewing needle, and a notched cork, and a bowl of water. Rest the needle in the notched cork, and float it on the water.

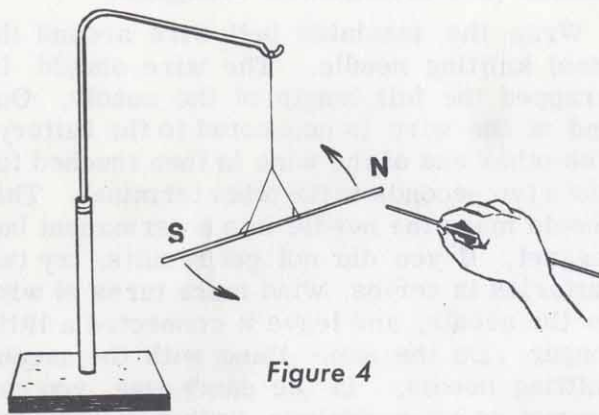

Figure 4

Hold the compass near the North Pole of the needle. What happens? Does the South Pole of the needle attract the North or South Pole of the compass? Try this with the second magnetized needle. See if you can prove the rule that like poles repel (drive away) and unlike poles attract.

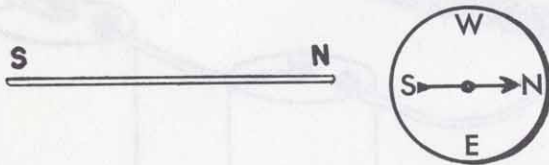

Figure 5

Connect one end of a wire loop to the battery and run the wire directly over the compass. Touch the other end of the wire to the battery. Which way does the compass point now? If you get some motion out of the compass needle, this proves there is a magnetic field around the wire when current is flowing. This relation between electricity and magnetism is the thing that makes electric motors and generators work.

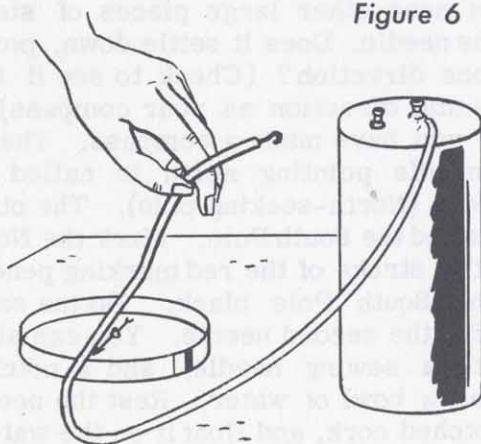

Figure 6

Make Many From One

Lay the third needle (unmagnetized) on a table and stroke it with one of the magnetized needles. (See diagram) Always stroke it in the same direction. Raise the magnetized needle at least two inches on each return stroke. Thus you can magnetize the needle by using the other needle.

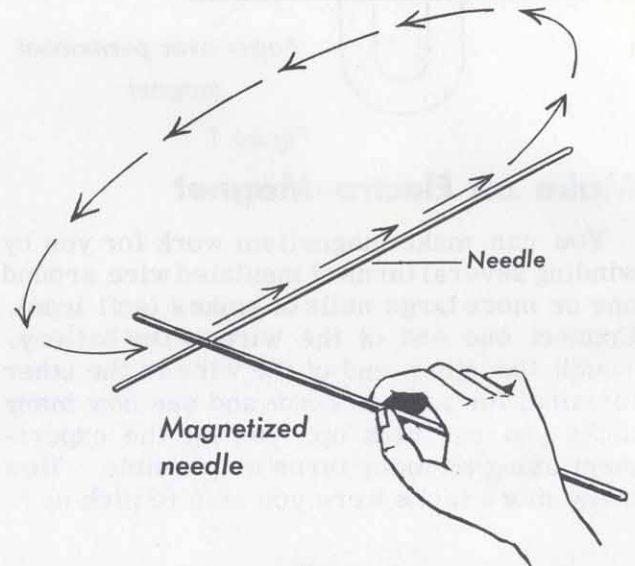
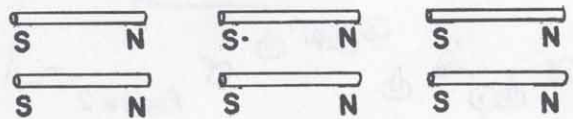

Figure 7

Use the wire cutters to cut the first magnetized needle in short lengths. (Cover the needle with a cloth to keep the pieces from flying.) Can you show by using the compass that each piece is a complete magnet? Hold one end, then the other, of each piece to a compass. Does each piece have both a North Pole and a South Pole?



Magnetism and Animals

The things you have done show that electricity and magnetism are related in many ways. Magnetism is mysterious, and there are still things to discover about it. It is thought that animals and birds are aided in their sense of direction by magnetism. It is commonly known that when a person gets lost in the woods, he tends to go around in circles. Possibly this is caused by the earth's magnetic field.

What Did You Learn?

1. Where are natural magnets obtained?
2. How can artificial magnets be made?
3. What material is needed for a permanent magnet? For a temporary magnet?
4. How can you find out which is the North Pole of an unmarked magnet?
5. How many poles does a magnet have?
6. Which magnetic poles attract each other?
7. Why couldn't you make a compass out of a strip of plastic?
8. What causes the compass to change direction when a wire carrying battery current is held over the needle?
9. List the materials you would need and tell how you would build a homemade compass.
10. Tell what you enjoyed most about becoming acquainted with mysterious magnetism.

